

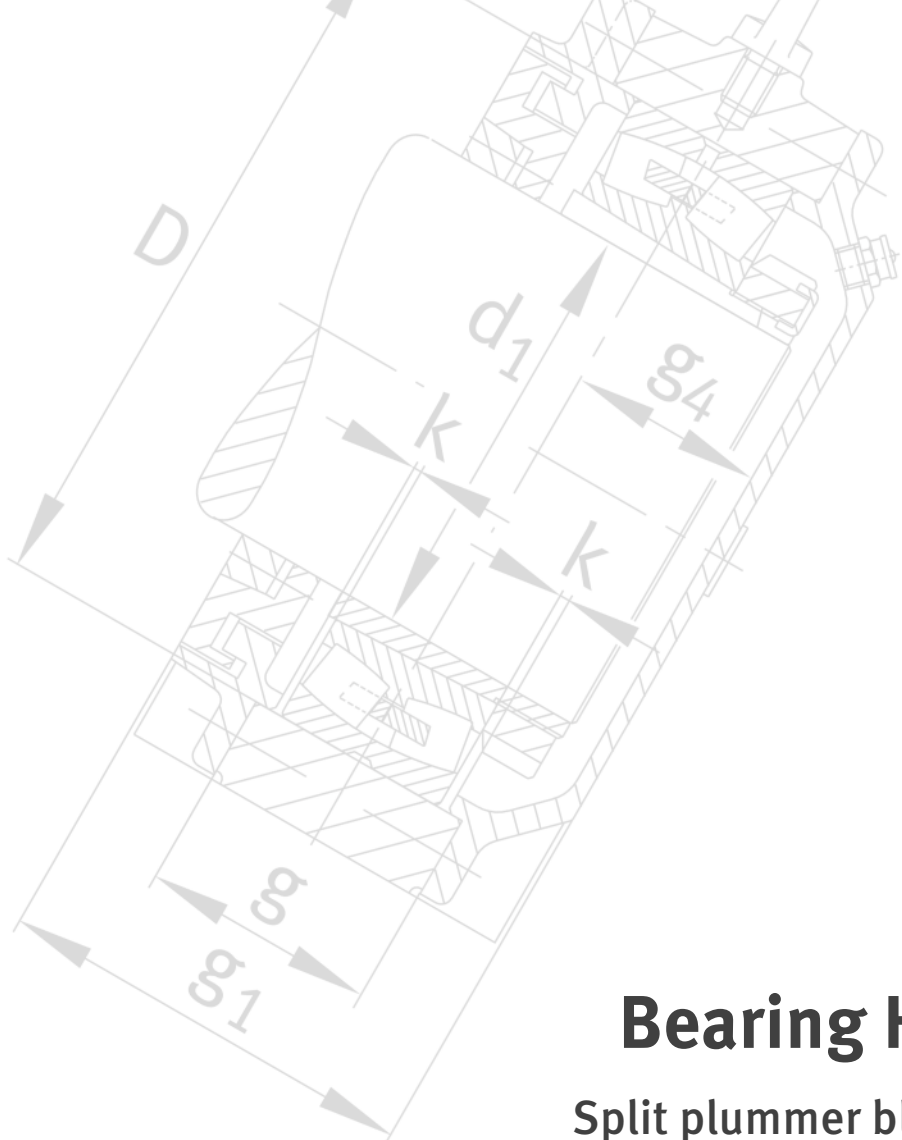

Bearing Housings

Split plummer block housings
Unsplit plummer block housings
Take-up housings
Flanged housings
Housings for specific industrial and
railway applications



Bearing Housings

- Split plummer block housings
- Unsplit plummer block housings
- Take-up housings
- Flanged housings
- Housings for specific industrial and railway applications

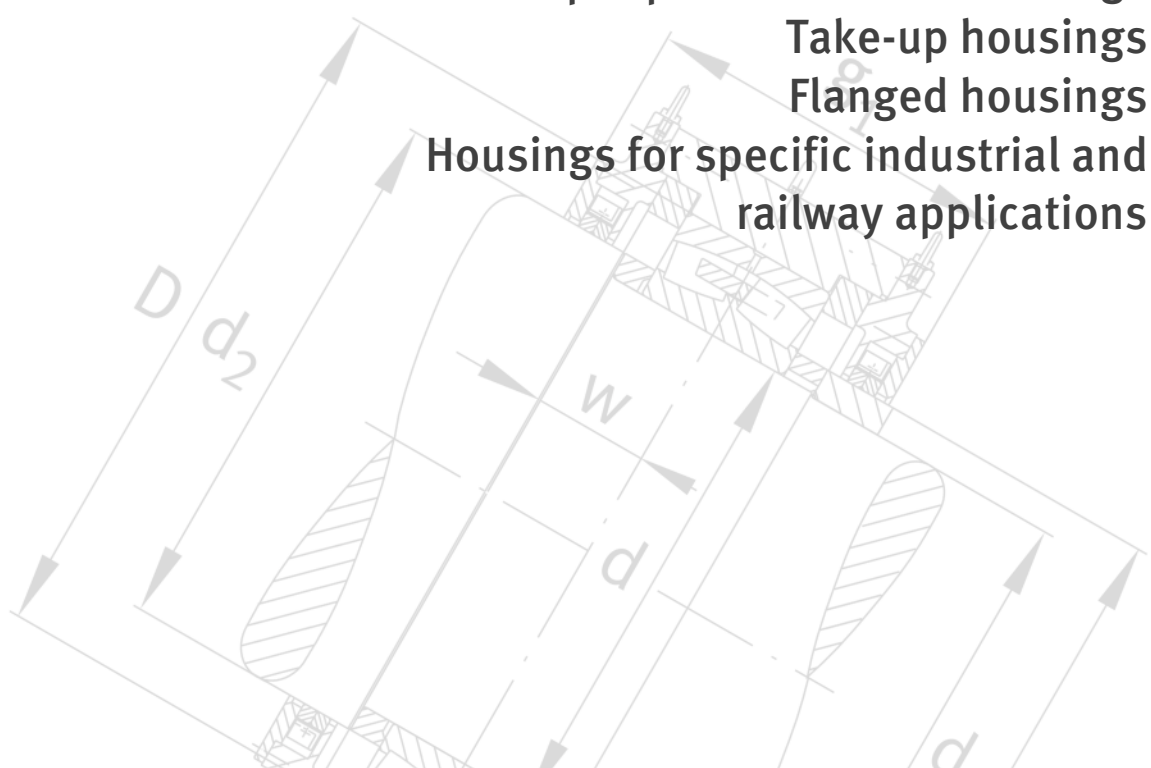

All data have been prepared with a great deal of care and checked for their accuracy. However, no liability can be assumed for any incorrect or incomplete data. We reserve the right to make technical modifications.

© Schaeffler Technologies AG & Co. KG

Issued: 2015, November

Reproduction in whole or in part without our authorisation is prohibited.

Foreword

Schaeffler Technologies

Schaeffler Technologies with its brands INA and FAG is a leading worldwide supplier of rolling bearings, spherical plain bearings, plain bearings, linear products, accessories specific to bearings and comprehensive maintenance products and services. Schaeffler has approximately 40 000 catalogue products manufactured as standard, providing an extremely wide portfolio that gives secure coverage of applications from 60 industrial market sectors.

The central factors responsible for this success are our outstanding strength in innovation, our global focus on local customer proximity, highly developed manufacturing methods, extremely high quality standards in all processes and our ability to transform specific customer requirements quickly and accurately into cost-effective solutions. Against this background of expertise, knowledge and experience together with our wide range of catalogue items, we see ourselves as a high performance, customer focussed partner.

Research and development

As a company looking to the future, we are especially active in the field of research and development. The key areas in this respect include not only research into fundamental principles, materials technology, tribology and calculation but also extensive inspection and test methods as well as activities to optimise manufacturing technology. This is oriented towards ensuring the continuous development, improvement and application of our products in the long term.

We carry out research and development on a global basis. Our development centres are linked with each other worldwide and are thus in a position to exchange current information on a very short timescale as well as access and communicate the most recent data. This ensures that a uniform level of knowledge and information is available worldwide.

In addition to continued development of standard products, we work closely in research and development activities with our customers where specific customer solutions are required. They can thus benefit from the best product for their application, with the maximum possible performance capacity at a cost-effective price.

Foreword

Worldwide presence

Through a closely knit network of development and manufacturing sites, sales companies and an international distribution structure, we are represented throughout the world. This global presence ensures effective linkage between the major markets in Europe, India, South East Asia/Pacific Region, East Asia, North and South America. As a result, we have an on-site presence with service and technical advice in close proximity to the customer.

We take orders from throughout the world and make deliveries worldwide too. Furthermore, we support our customers worldwide in resolving their bearing arrangement requirements, respond to technical queries and develop specific bearing arrangement solutions in local partnership with our customers.

Together we move the world

For us, technical progress means never standing still. In partnership with you, we are continually working on new solutions so that your vision and our technical ideas can continue to become a reality, to your benefit.

With our products and our knowledge, we can together continue to fulfil the challenges of your market in relation to rolling bearing arrangements. To this end, this catalogue is an important instrument.

Housings catalogue GK 1

Catalogue GK 1, Bearing Housings, describes the range of standard housings and gives essential information on housings for specific industrial and railway applications.

The catalogue contains all the information necessary for the selection of standard housings. The suitable housing can be selected and configured for a wide variety of different applications, for example in relation to the required bearing arrangement type, lubrication or housing seals. Through the allocation of the suitable bearing to each housing, extensive geometrical data and a large amount of other information, this catalogue is a comprehensive tool for providing information and facilitating advisory work.

Standard housings

The standard housings comprise split and unsplit plummer block housings, take-up housings and flanged housings.

In the case of split plummer block housings, the upper section of the housing can be removed. This gives significantly simpler mounting and maintenance. Unsplit plummer block housings are used where the bearing arrangement is subjected to very high loads.

Take-up housings were developed specifically for tensioner drum bearing arrangements in belt conveyor plant. There is a yoke-shaped drawbar eye for attachment to the tensioning device.

Flanged housings have a flange perpendicular to the shaft axis and thus offer the ideal adjacent construction for numerous machines and pieces of equipment where the use of plummer block housings would be too demanding.

Special housings

Special housings are used in particularly challenging applications where not all the requirements can be fulfilled by the use of standard housings. Apart from specific industrial applications, these are principally applications from the railway sector.

Special housings are developed in close cooperation and consultation with the customer. Schaeffler uses its comprehensive know-how of rolling bearing technology in order to ensure that every housing is optimally matched to the specific application.

This catalogue contains selected examples giving an insight into the diverse areas of application and possibilities of housings for specific industrial and railway applications.

Foreword

Current level of technology

The data in the catalogue represent the current level of technology and manufacture as of November, 2015.

Any data in earlier publications that do not correspond to the data in this catalogue are therefore invalid.

Definition of the Attention symbol

This catalogue predominantly gives descriptions of standard housings. Since these are used in numerous applications, we cannot make a judgement as to whether any malfunctions will cause harm to persons or property.

Follow instructions

It is always and fundamentally the responsibility of the designer and user to ensure that all specifications are observed and that all necessary information is communicated to the end user. This applies in particular to applications in which product failure and malfunction may constitute a hazard to human beings.



If guidelines marked with the Attention symbol are not observed, damage or malfunctions in the product or the adjacent construction may occur.

medias[®] professional electronic information system

medias[®] professional, the proven selection and information system, presents the INA and FAG catalogue products in electronic format. As with the printed catalogue, this gives our customers product information on both brands in a single data source. This saves time and gives easier handling.

medias[®] professional is available online in several languages, is easy to navigate and is particularly clear thanks to the use of numerous pictures, diagrams and models. There are also highly representative application examples, classified by market sector.

Datasheets on the bearings and bearing housings can be generated as PDF files. It includes a lubricant database and also the web2CAD link for direct download and inclusion of 3D models.

medias[®] professional focusses on the individual bearing. The complete shaft can be simulated and any influences on the bearings arising from its deformation can be determined using the calculation program BEARINX. This program can also be made available to direct customers as BEARINX-online via the Internet (for conditions, see the INA/FAG homepage).



<http://medias.schaeffler.com>

Selection wizard for bearing housings in *medias*[®] *professional*

The selection wizard for bearing housings in *medias*[®] *professional* gives comprehensive assistance in the selection of housings and housing units. It takes account of the environmental conditions and the requirements placed on the bearing arrangement as well as the characteristics of the housings and the bearings suitable for the housings. Once the specified data has been inputted, the software generates detailed lists of results that also contain information on further accessories.

In conclusion, *medias*[®] *professional* is a comprehensive, reliable system to help you help yourself answer many questions on rolling bearing technology by electronic means, quickly and at any location.



<http://bit.ly/HousingSelectionEN>

medias[®] interchange

medias[®] interchange is available online and assists in the selection process where rolling bearings or housings from other manufacturers are to be replaced by products of the INA and FAG brands.

If a rolling bearing and housing designation is entered in *medias*[®] interchange, this will indicate the manufacturer and INA or FAG designations. A traffic light system will quickly indicate whether and to what extent the INA or FAG part is interchangeable. Green indicates fully interchangeable, yellow indicates conditional interchangeability and red indicates non-interchangeable.



<http://bit.ly/InterchangeEN>

Other technical publications

This catalogue contains split and unsplit plummer block housings as well as take-up housings and flanged housings. In addition, it also gives an overview of housings for specific industrial and railway applications, on which detailed information is provided in a series of other technical publications.

Furthermore, we develop and manufacture many other products and systems that are of significant interest in terms of technical progress and cost-effectiveness for rotary and linear bearing arrangements as well as for the automotive sector. These are covered in separate technical publications that can be obtained upon request.



www.medien.schaeffler.com

Foreword

Catalogue SG 1 for Insert Bearings and Housing Units

In addition to the bearing housings described in Catalogue GK 1, which are predominantly for spherical roller bearings, barrel roller bearings and self-aligning ball bearings with a tapered or cylindrical bore, Schaeffler also offers a wide range of housing units with insert bearings. The insert bearings are based on single row deep groove ball bearings.

Insert bearings and housing units are robust, ready-to-fit machine elements for the design of economical bearing arrangements. These products are available in many different series, have proven effective over many years and predominantly comprise a housing fitted with an insert bearing. The housing bore and the bearing outer ring have a spherical profile and are matched to each other. This allows the bearing ring in the housing to adapt to static angular misalignment of the shaft.

Due to their special method of location, principally by means of an eccentric locking collar or grub screws, the insert bearings can be easily located on the shaft, *Figure 1* and *Figure 2*. They are particularly easy to fit when they are used in combination with drawn shafts. The insert bearings are fitted with multi-piece seals that effectively protect the rolling element set against contamination and moisture, even under difficult and critical operating conditions.

Further information

- The complete catalogue range can be found in Catalogue SG 1, Insert Bearings and Housing Units.
- Download and ordering: <http://medien.schaeffler.de>.

Insert bearings

The outer rings of the insert bearings have a spherical or cylindrical outside surface. The insert bearings are available with a metric or inch size bore. Black Series insert bearings with a Durotect B coating have basic anti-corrosion protection. Corrosion-resistant insert bearings are available in a high-grade steel version or with the Corrotect coating.

- ① Eccentric locking collar
② Grub screws in inner ring

Figure 1
Location variants
of insert bearings

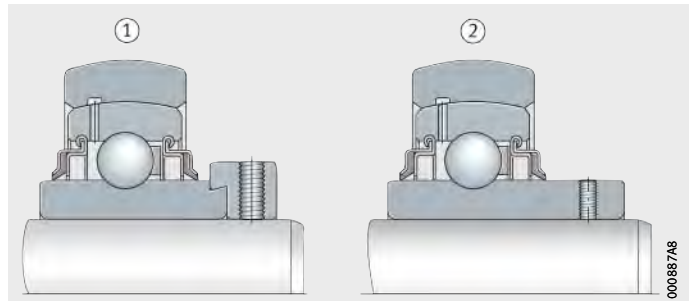

- ① Adapter sleeve and locknut
② Drive slot

Figure 2
Location variants
of insert bearings

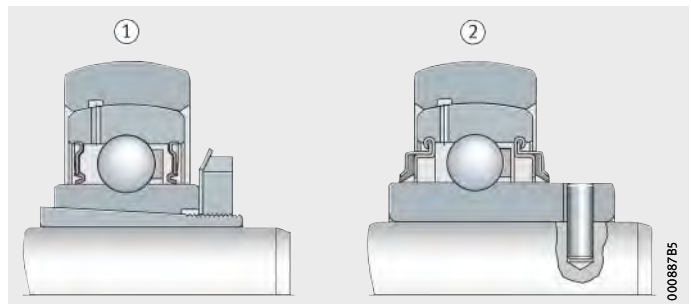

Housing units

Housing units are available as plummer block, flanged and take-up housing units in numerous different designs. The units are ready-to-fit and comprise cast iron or sheet steel housings in which insert bearings are integrated, *Figure 3* to *Figure 6*.

PASE

Figure 3
Plummer block housing unit
with cast iron housing

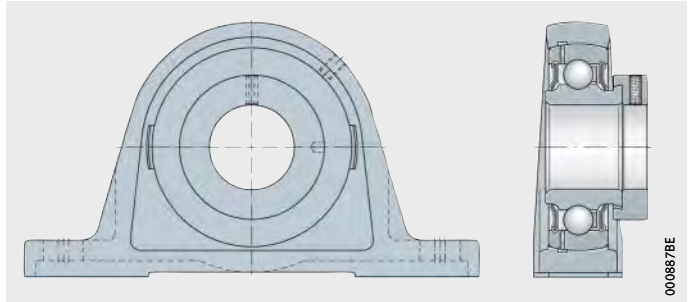

PCJT

Figure 4
Flanged housing unit
with cast iron housing

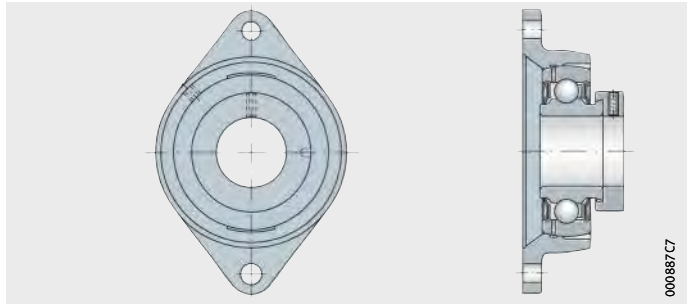

PB

Figure 5
Plummer block housing unit
with sheet steel housing

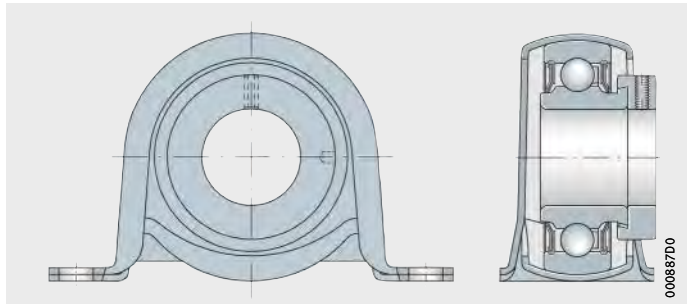

GRA

Figure 6
Flanged bearing unit
with sheet steel housing

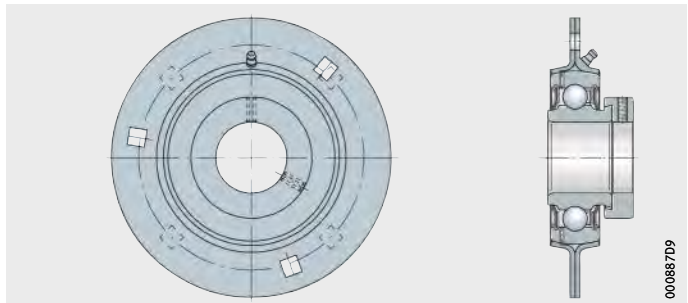

Contents

	Page
Product index	12
Tab index	17
Technical principles.....	18
Split plummer block housings.....	49
Split plummer block housings SNV	52
Split plummer block housings S30	130
Split plummer block housings SNS	146
Split plummer block housings RLE.....	214
Split plummer block housings KPG, KPGZ	228
Split plummer block housings LOE	246
Unsplit plummer block housings.....	265
Plummer block housing units VRE3	268
Unsplit plummer block housings BNM	290
Unsplit plummer block housings BND.....	300
Take-up housings SPA	334
Flanged housings	353
Flanged housings F112	356
Flanged housings F5	364
Housings for specific industrial and railway applications.....	379
Housings for special industrial applications	380
Housings for railway applications.....	390
Mounting and maintenance	405
Addresses	430

Product index

	Page
BDK	Cover, for split plummer block housings SNS, Bolt-on design 149
BND...-AF	Plummer block housing, unsplit, closed on one side, with cover, locating bearing design 302
BND...-AL	Plummer block housing, unsplit, closed on one side, with cover, non-locating bearing design 302
BND...-BF	Plummer block housing, unsplit, for through shaft, with cover, locating bearing design 302
BND...-BL	Plummer block housing, unsplit, for through shaft, with cover, non-locating bearing design 302
BNM...-AF	Plummer block housing, unsplit, closed on one side, with cover, locating bearing design 292
BNM...-AL	Plummer block housing, unsplit, closed on one side, with cover, non-locating bearing design 292
BNM...-BF	Plummer block housing, unsplit, for through shaft, locating bearing design 292
BNM...-BL	Plummer block housing, unsplit, for through shaft, non-locating bearing design 292
BTAC	Bolt-on seal, for split plummer block housings SNS 149
DH	Double lip seal, for split plummer block housings SNV 55
DHV	V ring seal, for split plummer block housings SNV 55
DK	Cover, for split plummer block housings S30 132
DKV	Cover, plastic, for split plummer block housings SNV 55
DKVT	Cover, steel and fluoro rubber FKM, for split plummer block housings SNV 55

	Page
F5..-A	Flanged housing, closed on one side, with cover 366
F5..-B	Flanged housing, for continuous shaft 366
F112	Flanged housing..... 358
FE	Locating ring, for flanged housings F5 367
FRM	Locating ring, for split plummer block housings SNV 55
FRM	Locating ring, for split plummer block housings S30..... 132
FRM	Locating ring, for flanged housings F5 367
FSV	Felt seal, for split plummer block housings SNV 55
KPG	Plummer block housing, split, with high-pressure packing, for bearings with tapered bore 230
KPGZ	Plummer block housing, split, with high-pressure packing, for bearings with cylindrical bore 230
LOE..-AF	Plummer block housing, split, closed on one side, with cover, locating bearing design 248
LOE..-AL	Plummer block housing, split, closed on one side, with cover, non-locating bearing design 248
LOE..-BF	Plummer block housing, split, for through shaft, locating bearing design 248
LOE..-BL	Plummer block housing, split, for through shaft, non-locating bearing design..... 248
NDK	Cover, for split plummer block housings SNS 149
NFR	Locating ring, for split plummer block housings SNS 149
NTC	Taconite seal, for split plummer block housings SNS..... 149
NTS	Labyrinth seal, for split plummer block housings SNS..... 149
NTSG	Labyrinth seal, split, for split plummer block housings SNS..... 149

Product index

	Page
RLE...-AF	Plummer block housing, split, closed on one side, with cover, locating bearing design 216
RLE...-AL	Plummer block housing, split, closed on one side, with cover, non-locating bearing design 216
RLE...-BF	Plummer block housing, split, for through shaft, locating bearing design 216
RLE...-BL	Plummer block housing, split, for through shaft, non-locating bearing design 216
S30...-N-FZ-AB	Plummer block housing, split 132
SNV	Plummer block housing, split 54
SNS...-B	Plummer block housing, split, for Bolt-on seal 148
SNS...-H	Plummer block housing, split, main design for labyrinth and Taconite seal 148
SNS...-Z	Plummer block housing, split, additional design for labyrinth and Taconite seal 148
SPA...-AF	Take-up housing, unsplit, closed on one side, with cover, locating bearing design 336
SPA...-AL	Plummer block housing, unsplit, closed on one side, with cover, non-locating bearing design 336
SPA...-BF	Take-up housing, unsplit, for through shaft, locating bearing design 336
SPA...-BL	Take-up housing, unsplit, for through shaft, non-locating bearing design 336
TCV	Taconite seal, for split plummer block housings SNV 54
TSV	Labyrinth seal, for split plummer block housings SNV 54
VR3	Plummer block housing, unsplit 270
VRE3	Plummer block housing unit, unsplit, with bearings and shaft 270
VRW3	Shaft, for unsplit plummer block housings VR3 270



00087869



0008408F

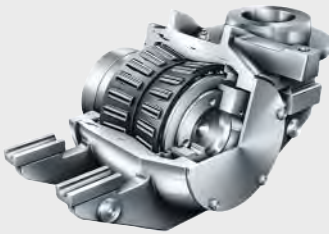

00085602



00085846

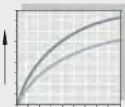

00015CE8

Technical principles



0008786D

Split plummer block housings

- SNV
- S30
- SNS
- RLE
- KPG, KPGZ
- LOE

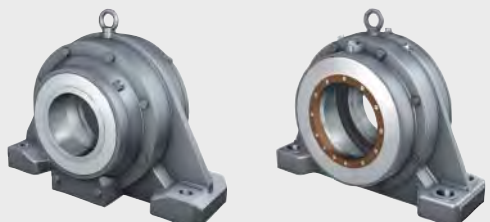

0008409B

Unsplit plummer block housings

- VRE3
- BNM
- BND



000840B1

Take-up housings

- SPA



000840C7

Flanged housings

- F112
- F5



00085614

Housings for specific industrial and railway applications



0008584A

Mounting and maintenance



0001A281

Addresses

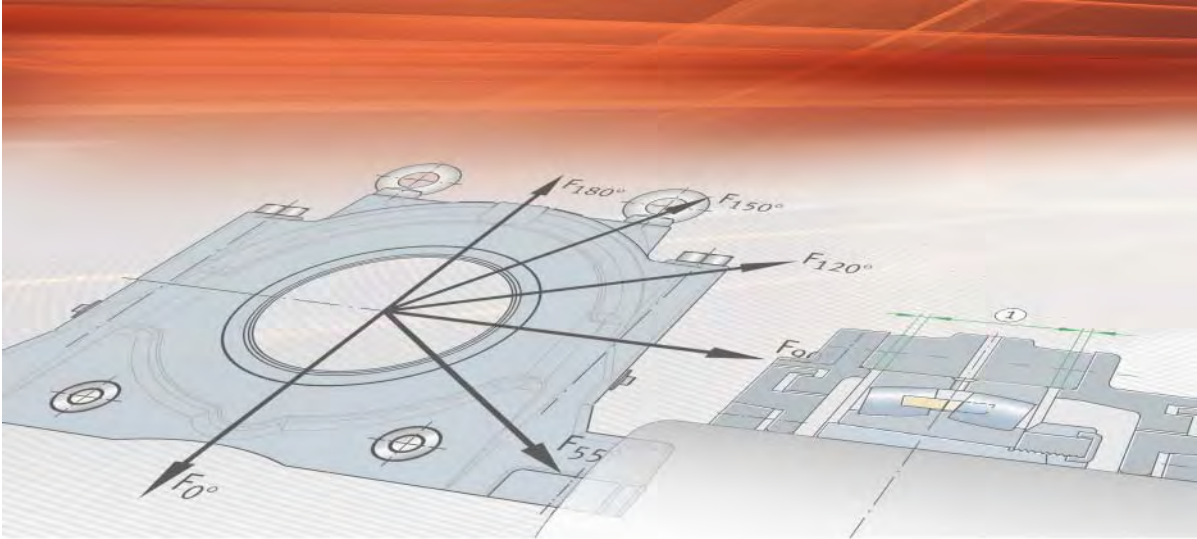

Technical principles

Standard housings

Materials and anti-corrosion protection

Design of bearing arrangements

Sealing

Lubrication

Load carrying capacity

Mounting and dismantling

Special solutions



Technical principles

	Page
Standard housings	Available designs 20
	Housing concepts..... 22
Materials and anti-corrosion protection	Materials..... 23
	Flake graphite cast iron 23
	Spheroidal graphite cast iron 23
	Cast steel..... 24
	Anti-corrosion protection 24
Design of bearing arrangements	Locating and non-locating bearing arrangements 25
	Axial length compensation 25
	Transmission of axial forces 25
	Locating and non-locating bearing concepts..... 25
Sealing	Functions of the sealing arrangement..... 28
	Seals..... 28
	Contact seals 28
	Non-contact seals 29
	Combined seals 30
	Covers..... 30
Lubrication	Principles 31
	Functions of the lubricant..... 31
	Housing selection and type of lubrication 32
	Housings for grease lubrication 33
	Initial greasing 33
	Relubrication 34
	Greases 34
	Housings for oil lubrication 35
	Lubrication methods 35
	Oil selection 36
Load carrying capacity	Load carrying capacity of split and unsplit plummer block housings 37
	Rupture loads 37
	Permissible load 38
Mounting and dismantling	Fundamental specifications..... 39
	Cleanliness..... 39
	Eye bolts..... 39
	Location of housings 41
	Surface quality of the mounting surface..... 41
	Level of mounting surfaces..... 41
	Tightening torques for foot screws 42
	Horizontal location..... 43
	Location of bearings on the shaft 44
	Bearing seats on the shaft..... 44
	Hydraulic method 44
	Spherical roller bearings with tapered bore and adapter sleeve 44
	Maintenance 46
	Regular maintenance work 46
Special solutions	Special solutions for standard housings 47
	Special solutions and additional services..... 47
	Special solutions for plummer block housings SNV..... 48

Standard housings

Available designs

Standard housings		Split plummer block housings		
		SNV	S30	SNS
Shaft diameter	over mm	20	110	115
	<i>inch</i>	$\frac{3}{4}$	–	$\frac{47}{16}$
	incl. mm	160	150	530
	<i>inch</i>	$5\frac{1}{2}$	–	$19\frac{1}{2}$
Bearing type				
Self-aligning ball bearings		●	–	–
Spherical roller bearings		●	●	●
Barrel roller bearings		●	–	–
Cylindrical roller bearings		–	–	–
Deep groove ball bearings		●	–	–
Angular contact ball bearings		–	–	–
Spherical roller bearings, split		●	●	●
Mounting method				
On adapter sleeve		●	●	●
On withdrawal sleeve		–	–	–
On adjustment sleeve		–	–	–
On cylindrical seat		●	●	●
Lubrication				
Grease		●	●	●
Oil		●	–	●
Seal				
Labyrinth seal		■	–	■
Taconite seal		■	–	■
Double lip seal		■	–	–
V ring seal		■	–	–
Felt seal		■	■	–
Bolt-on seal		–	–	■
Split labyrinth seal		–	–	■
Split Taconite seal		–	–	■
High-pressure packing		–	–	–

- Suitable
- Available design



				Unsplit plumber block housings			Take-up housings	Flanged housings	
RLE	KPG	KPGZ	LOE	VRE3	BNM	BND	SPA	F112	F5
180	470	500	50	25	150	60	50	20	20
-	-	-	-	-	-	-	-	-	-
500	1250	1320	240	120	400	420	400	60	100
-	-	-	-	-	-	-	-	-	-
-	-	-	-	-	-	-	-	●	●
●	●	●	●	-	●	●	●	-	●
-	-	-	-	-	-	-	-	-	●
-	-	-	-	●	-	-	-	-	-
-	-	-	-	●	-	-	-	-	-
-	-	-	-	●	-	-	-	-	-
-	●	●	-	-	-	-	-	-	-
-	-	-	●	-	-	●	●	-	●
●	-	-	-	-	●	-	-	-	-
-	●	-	-	-	-	-	-	-	-
●	-	●	●	●	-	●	-	●	-
●	●	●	-	●	●	●	●	●	●
-	-	-	●	-	-	-	-	-	-
■	-	-	■	-	■	■	■	-	-
-	-	-	-	-	-	■	■	-	-
-	-	-	-	-	-	-	-	-	-
-	-	-	-	■	-	-	-	-	-
-	-	-	-	■	-	-	-	■	■
-	-	-	-	-	-	-	-	-	-
-	-	-	-	-	-	-	-	-	-
-	-	-	-	-	-	-	-	-	-
-	-	-	-	-	-	-	-	-	-
-	■	■	-	-	-	-	-	-	-

Standard housings

Housing concepts

FAG standard housings are subdivided, in accordance with their fundamental design, into:

- split plummer block housings
- unsplit plummer block housings
- take-up housings
- flanged housings.

In the case of split plummer block housings, the housing body is split into an upper section and a lower section. This gives significantly simpler mounting and maintenance. The two halves of a housing form a matched pair and must not be interchanged with parts from other housings.

In the case of unsplit plummer block housings, the housing body is a single piece, so the bearing seat is free from parting lines. The housings are used where the bearings are subjected to very high loads.

The unsplit plummer block housings also include plummer block housing units VRE3. These are made available as completely assembled and greased bearing arrangement units comprising a housing, seals, bearings and shaft.

Take-up housings SPA were developed specifically for tensioner drum bearing arrangements in belt conveyor plant. The housings are unsplit. There is a yoke-shaped drawbar eye for attachment to the tensioning device.

Flanged housings have a flange perpendicular to the shaft axis and thus offer the ideal adjacent construction for numerous machines and pieces of equipment where the use of plummer block housings would be too demanding.



Materials

Depending on the housing series, the standard material used for FAG standard housings is flake graphite cast iron, spheroidal graphite cast iron or cast steel.

The material is generally indicated by a suffix in the housing designation. This indication is omitted in the case of some housings where these are only available in one material variant.

Suffixes:

- L for flake graphite cast iron
- D for spheroidal graphite cast iron
- S for cast steel.

By agreement, housings made from other materials are also available. The material should be selected on the basis of a careful analysis of the application and the associated requirements.

Flake graphite cast iron

For standard housings made from flake graphite cast iron, cast iron in accordance with DIN EN 1561 is generally used. In these cast materials with a iron/carbon/silicon base, the graphite inclusions are present in lamellar form. Under tensile load, these act as internal notches. The tensile strength of flake graphite cast iron is therefore limited and its ductility is comparatively low. The compressive strength of this alloy is, however, higher than the tensile strength by a factor of 4 and these alloys also have good inherent stability.

Flake graphite cast iron is therefore used in the case of housings with simple requirements. Furthermore, flake graphite cast iron represents the most economical variant of the cast materials available for use in housings.

Spheroidal graphite cast iron

For standard housings made from spheroidal graphite cast iron, cast iron in accordance with DIN EN 1563 is generally used.

Due to an addition of magnesium or, more rarely cerium or calcium, the graphite inclusions adopt a spheroidal form during casting. As a result, the tensile strength and ductility are higher than those of the grades with a lamellar graphite form.

Spheroidal graphite cast iron is therefore used in the case of housings with an increased profile of requirements. The costs of spheroidal graphite cast iron are between those for flake graphite cast iron and cast steel.

Materials and anti-corrosion protection

Cast steel For standard housings made from cast steel, steel in accordance with DIN EN 10293 is generally used. Both unalloyed and alloyed steels are suitable for casting. The unalloyed cast steel used for housings combines moderate to high strength values with high elongation at fracture.

Cast steel is therefore used in the case of housings with high requirements for mechanical properties as well as a requirement for high ductility.

The costs of cast steel are higher than the costs for flake graphite cast iron or spheroidal graphite cast iron. It is therefore recommended that it should be checked whether the material is really necessary in relation to the requirements of the specific application.

Anti-corrosion protection All outer surfaces of standard housings not machined by chip-forming methods and the locating surfaces on the lower housing section have a universal paint coating. The coating can be finished using all synthetic resin, polyurethane, acrylic, epoxy resin, chlorinated rubber, nitrocellulose and acid-hardening hammer tone finishes.

Inner and outer surfaces machined by chip-forming methods are provided with anti-corrosion protection that can be easily removed. It is recommended that only volatile solvents and lint-free cloths should be used.

If there are particular requirements relating to paint coating and anti-corrosion protection, special solutions are possible. If particular specifications are presented by the customer, we check their feasibility and these can be implemented if the result is positive.



Design of bearing arrangements

Locating and non-locating bearing arrangements

The guidance and support of a rotating shaft generally requires at least two bearings arranged at a certain distance from each other. There are various possibilities for achieving this arrangement. In many cases, the locating/non-locating bearing arrangement is used in which one bearing position has a locating bearing arrangement and the other has a non-locating bearing arrangement. In addition, the adjusted bearing arrangement and the floating bearing arrangement are frequently used arrangements.

Axial length compensation

On a shaft supported by two radial bearings, the distances between the bearing seats on the shaft and in the housing frequently do not coincide as a result of manufacturing tolerances. The distances may also change as a result of temperature increases during operation. These differences in distance are compensated in the non-locating bearing.

There are bearing types in which, due to the internal construction, the inner ring and outer ring cannot be displaced relative to each other. As a result, no axial length compensation between the shaft and housing can occur within the bearing. Examples include spherical roller bearings, barrel roller bearings and deep groove ball bearings. These bearings can only function as a non-locating bearing if the inner ring or outer ring has a fit that allows displacement. In the case of bearing housings, this means that the outer ring must be capable of displacement in the housing. The tolerance of the bearing seat in the housing is designed accordingly and is described in the information on accuracy for the specific housing series.

Transmission of axial forces

If axial forces must be transmitted, a locating bearing is necessary. The locating bearing also gives axial guidance of the shaft. In order to prevent axial preload, shafts with more than two bearings have only one locating bearing.

Locating and non-locating bearing concepts

In order to achieve locating bearing arrangements as well as non-locating bearing arrangements, one of the following concepts is applied in each housing series:

- housings in a locating bearing design and non-locating bearing design, see page 26
- housings with locating rings, see page 27.

A special case here is the unsplit plummer block housings VR3, where two bearing positions are integrated in one housing. Complete plummer block housing units VRE3 can be ordered that, depending on their design, contain a locating/non-locating bearing arrangement, an adjusted bearing arrangement or a floating bearing arrangement.

Design of bearing arrangements

Housings in locating bearing design and non-locating bearing design

In this housing concept for the implementation of a locating or non-locating bearing arrangement, the housing must be ordered as necessary in a locating bearing design or a non-locating bearing design. This applies to the housings RLE, KPG, KPGZ, LOE, BNM, BND and SPA.

In the case of the locating bearing design, the bearings are axially clamped between the covers on the housings, *Figure 1*. In the case of the non-locating bearing design, the covers have shorter centring collars. As a result, the bearing can be axially displaced, *Figure 2*.

When ordering, the designation indicates whether the housing should be supplied in a locating or non-locating bearing design.

① Centring collars on covers for axial location of the bearing

Figure 1
Housing in locating bearing design

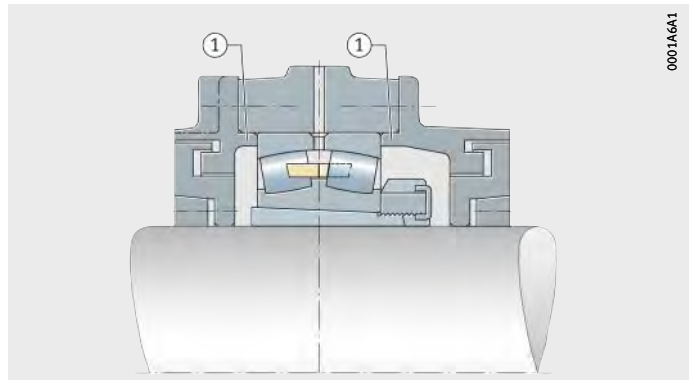

① Bearing can be axially displaced

Figure 2
Housing in non-locating bearing design

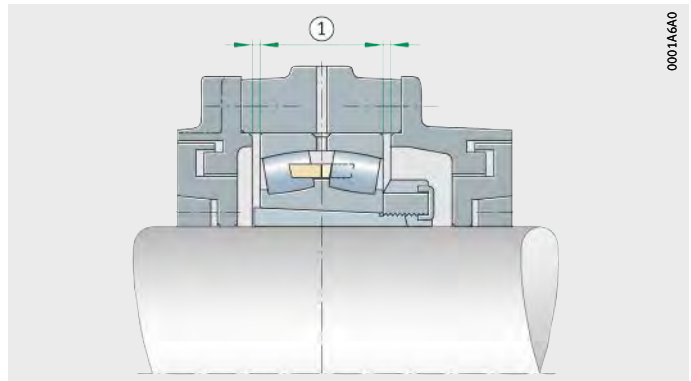



Housings with locating rings

In this housing concept for the implementation of a locating or non-locating bearing arrangement, locating rings are available as accessories that can be used to set the locating bearing function, *Figure 3*. This applies to the housings SNV, S30, SNS and F5.

In the case of these housings, the bearing seats are designed such that the bearing is capable of axial displacement and therefore acts as a non-locating bearing if locating rings are not inserted, *Figure 4*.

Once locating rings are inserted, the bearings are axially located. The locating rings are generally inserted in the housing on both sides of the bearing. Normally, an even number of locating rings is specified in order to achieve concentric seating of the bearing in the housing. In some cases, a single locating ring is sufficient.

The number of locating rings required is given in the dimension tables. Locating rings must be ordered separately.

① Locating rings give axial location of the bearing

Figure 3
Locating bearing arrangement, as a result of inserted locating rings

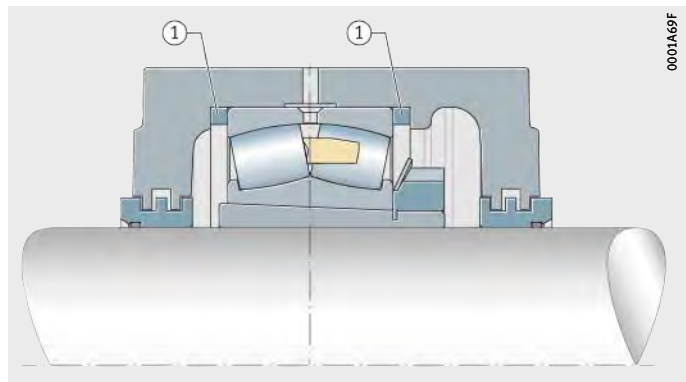

① Bearing can be axially displaced

Figure 4
Non-locating bearing arrangement, no locating bearing rings inserted

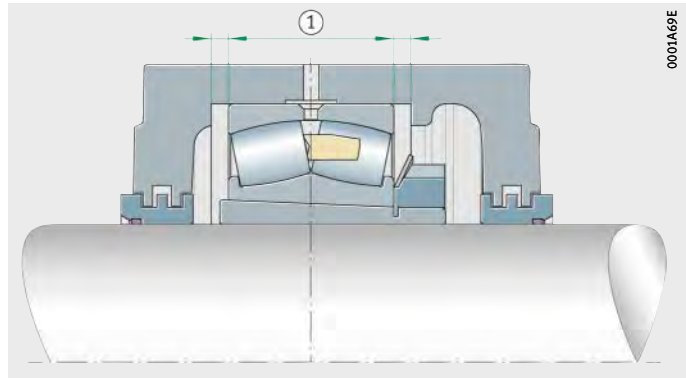

Sealing

Functions of the sealing arrangement

The sealing arrangement has a considerable influence on the operating life of a bearing arrangement. Its function is to retain the lubricant in the bearing and prevent the ingress of contaminants into the bearing.

Contaminants may have various effects:

- A large quantity of very small, abrasive particles causes wear in the bearing. The increase in clearance or noise brings the operating life of the bearing to an end.
- Large, overrolled hard particles reduce the fatigue life since pitting occurs at the indentation points under high bearing loads.

Seals

The rolling bearings normally used in bearing housings are spherical roller bearings, barrel roller bearings and deep groove ball bearings, which do not have their own sealing arrangement. The bearing position must therefore be sealed by means of the housing.

In order to seal the housing against the shaft, there are contact seals, non-contact seals and combinations of these are available, depending on the operating conditions.

Contact seals

Contact seals are normally in contact with the running surface under radial contact force. The contact force should be kept small to avoid an excessive increase in frictional torque and temperature. The frictional torque and temperature as well as the wear of the seal are also affected by the lubrication of the seal at the running surface, the roughness of the running surface and the sliding velocity.

In bearing housings, the contact seals used are mainly double lip seals, felt seals and felt seals with a V ring, *Figure 1*.

- ① Double lip seal
- ② Felt seal
- ③ Felt seal with V ring

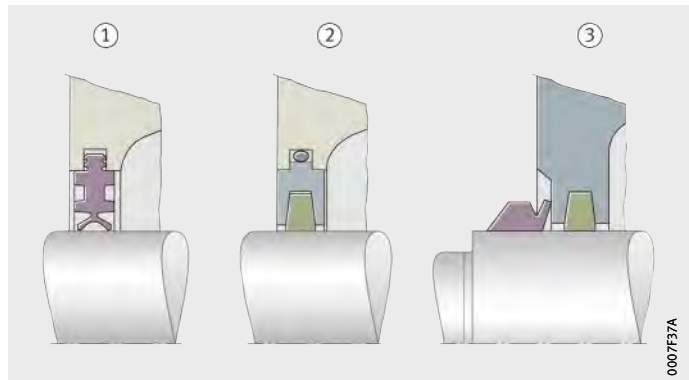

Figure 1
Examples of contact seals



Non-contact seals

With non-contact seals, there is no friction in the lubricant gap other than that due to lubricant friction itself. The seals do not undergo wear and remain capable of operation for a long period. Since they generate no heat, non-contact seals are also suitable for very high speeds.

In the case of these seals, the lubricant in the lubrication gap makes an important contribution to the sealing action. There is a possibility of separate relubrication in the case of some seals.

In bearing housings, the seals used are mainly radial labyrinths, axial labyrinths and combinations of these types, *Figure 2*.

- ① Radial labyrinth
- ② Axial labyrinth

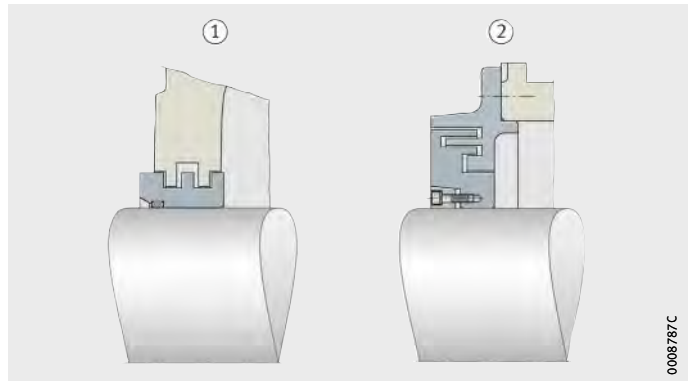

Figure 2

Examples of non-contact seals

Sealing

Combined seals

Where high requirements for sealing action are present, combined seals comprising contact sealing elements and non-contact sealing elements are often used, *Figure 3*. The combination of a labyrinth seal that can be relubricated with a V ring is also known as a Taconite seal. This seal is characterised by particularly good sealing action against dust and abrasive particles.

- ① Labyrinth and felt seal
- ② Taconite seal

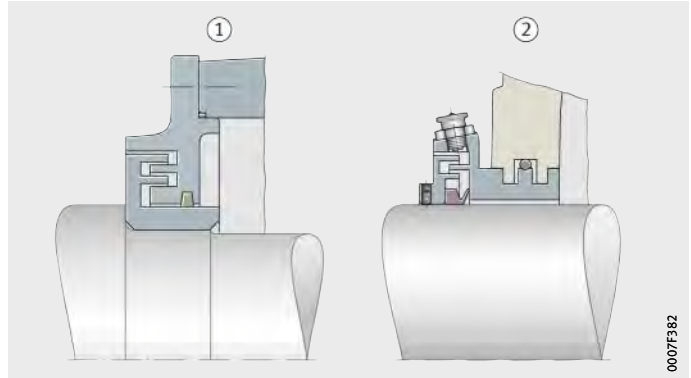

Figure 3
Example of combined seals

Covers

Where the shaft does not pass fully through the housing, one side of the housing is closed by means of a cover. In split housings, the cover is generally inserted in the lower half of the housing and the upper half of the housing is then set in place. In the case of unsplit housings, the cover is flange mounted on the housing.

The maximum operating temperatures of the covers are dependent on the materials used. In the case of some housings, it is possible to select from different designs.

Where a continuous shaft is present, many housings are also fitted with covers. These covers are not closed but are of a ring-shaped design and are sealed against the shaft.



Lubrication

Principles

Lubrication is an essential precondition for the reliable function and long operating life of rolling bearings.

Functions of the lubricant

The lubricant should, *Figure 1*:

- form a lubricant film on the contact surfaces that is sufficiently capable of supporting loads and therefore prevent wear and premature fatigue ①
- dissipate heat in the case of oil lubrication ②
- provide additional sealing for the bearing against external solid and fluid contaminants in the case of grease lubrication ③
- provide damping of running noise ④
- protect the bearing against corrosion ⑤.

- ① Formation of a lubricant film capable of supporting loads
- ② Heat dissipation in the case of oil lubrication
- ③ Sealing of the bearing against external contaminants in the case of grease lubrication
- ④ Damping of running noise
- ⑤ Protection against corrosion

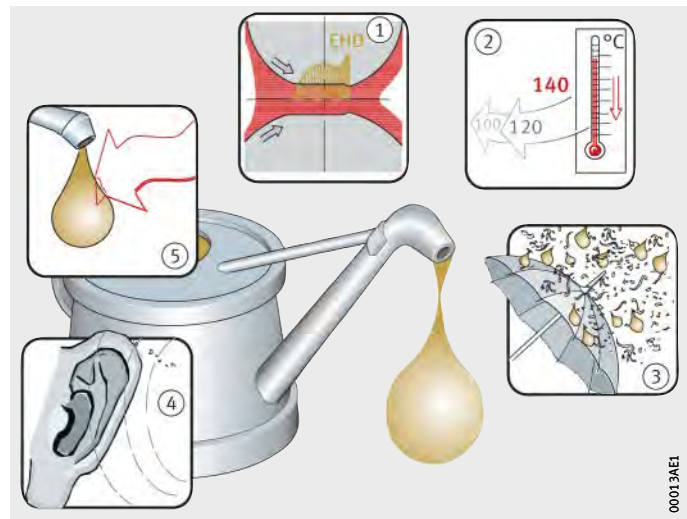

Figure 1
Functions of the lubricant

00013AE1

Lubrication

Housing selection and type of lubrication

The design of a bearing housing determines how the bearing position can be supplied with lubricant. This affects both the type of lubricant and the possibilities for replacing the lubricant after a certain operating duration.

Before a bearing housing is selected, the type of lubrication must be defined for the bearing, which means whether the bearing is to be lubricated with grease or oil. The following criteria must be taken into consideration.

Criteria for grease lubrication

Grease lubrication requires less work in design terms than oil lubrication. As a result, grease lubrication is normally used in preference.

The advantages of grease lubrication are as follows:

- less design work for feed systems than in the case of oil lubrication
- sealing action outwards due to a grease collar or grease-filled labyrinths
- reservoir effect due to storage of grease in the housing
- long operating life with little maintenance work (lifetime lubrication possible in certain circumstances).

Criteria for oil lubrication

In contrast to grease lubrication, oil lubrication allows the direct dissipation of heat from the bearing by means of the lubricant, especially at high speeds and loads. The best cooling action is achieved through the use of recirculating oil lubrication in conjunction with additional cooling of the oil.

The advantages of oil lubrication are as follows:

- the possibility of heat dissipation from the bearing
- flushing out of contaminant and wear particles
- good lubricant distribution and supply to contact areas
- very low friction losses when using minimal quantity lubrication.

FAG standard housings

Most FAG standard housings are designed for grease lubrication, while some are designed for oil lubrication, see table, page 20. There are also housing series that can be supplied in either a design for grease lubrication or a design for oil lubrication.



Housings for grease lubrication

In the case of FAG standard housings, grease lubrication is the most frequently used type of lubrication.

Where grease lubrication is applied, bearings can be operated in many applications with lifetime lubrication, which means that the grease quantity introduced at the time of mounting is sufficient for the entire bearing rating life in conjunction with suitable seals. If greater strain is present, the grease must be refreshed by means of targeted relubrication.

Initial greasing

The greasing of bearings and housings at the time of mounting is described as initial greasing.

Grease quantities

For initial greasing, the basic rule is that the bearing should be filled with grease to 100% and the free volume of the housing to 60%. The free volume is the space that remains in the housing once the bearing, shaft and seals have been fitted. In the case of housings with labyrinth or Taconite seals, the labyrinth passages must also be filled with grease.

As a variation from this basic rule, it is recommended in certain applications that the housing and seal cavities should be filled to 100%. One example is plummer block housings SNV in applications with lower speeds and a non-contact seal, where the grease is required to carry out a sealing function.

For plummer block housings BND and take-up housings SPA, the specification is always that the bearing and the free volume in the housing should be filled to 100%.

For many housing series, tables stating the recommended grease quantities for initial greasing are available.

The recommended degree of filling for greasing of the bearing may, as a function of the application and speed, deviate from 100%. A smaller grease quantity is thus recommended for very high speeds. This allows easier initial distribution of the grease as the bearing starts to move and restricts the associated increase in temperature.

Lubrication

Relubrication

If relubrication is carried out, additional grease is introduced into the housing at suitable positions. A facility must always be provided so that superfluous grease can exit the housing.

Positions for relubrication

For each bearing housing, positions for relubrication are provided that are matched to the characteristic of the bearing and housing. For relubrication, lubrication nipples are screwed in here.

Where bearings have a lubrication groove and lubrication holes, the grease can be introduced centrally into the housing if the housing is also provided with a suitable lubrication hole. The grease then travels directly to the raceway of the bearing.

Alternatively, the grease can be introduced into the side of the housing. The grease then travels via the end face of the bearing to the raceway.

For Taconite seals, and in some housings also for labyrinth seals, there are separate positions for relubrication of the seals.

Egress of superfluous lubricant

If an opened grease outlet hole or non-contact seal is present, there is no risk of overgreasing of the bearing. If the temperature reaches a higher level during relubrication due to the churning energy of the grease, it will return to its initial value after several hours of running once the excess grease has escaped.



In the interests of the environment, controlled metering must be ensured. Any grease that escapes via the grease outlet holes must be collected by means of a suitable device.

Automatic lubricators

In order to provide bearings with a reliable supply of lubricant for relubrication, the use of automatic lubricators is recommended. These make it possible to dispense a defined grease quantity at appropriate intervals. As part of its industrial services activities, Schaeffler offers suitable lubrication devices such as the lubrication system CONCEPT8, see page 422.

Greases

In order to achieve a long operating life and high operational security of the bearing arrangement, we recommend the use of the Arcanol rolling bearing greases. These are specifically developed and tested for bearing arrangements. As part of its industrial service activities, Schaeffler offers a comprehensive range of Arcanol greases, see page 419.

Further information

- TPI 168, Rolling Bearing Greases Arcanol
- TPI 176, Lubrication of Rolling Bearings
- WL 80382, FAG CONCEPT8.



Housings for oil lubrication

In addition to housings for grease lubrication, Schaeffler also offers housings designed for oil lubrication.

In the case of split housings, the parting line between the upper and lower sections of the housing must be sealed with a thin layer of a commercial sealant (with permanent elasticity). The covers on the housing must also be sealed.

Lubrication methods

The methods used for oil lubrication of FAG plummer block housings are:

- oil bath lubrication
- recirculating oil lubrication.

Oil bath lubrication

If oil bath lubrication is used, *Figure 2*, the oil level must reach the centre of the lowest rolling element. If the oil level is higher than this, the bearing temperature may increase at high circumferential velocities as a result of splashing losses. Furthermore, foaming of the oil may occur.

Oil bath lubrication is suitable for speed parameters up to $n \cdot d_M = 300\,000 \text{ min}^{-1} \cdot \text{mm}$. At $n \cdot d_M < 150\,000 \text{ min}^{-1} \cdot \text{mm}$, the bearing may be completely immersed.

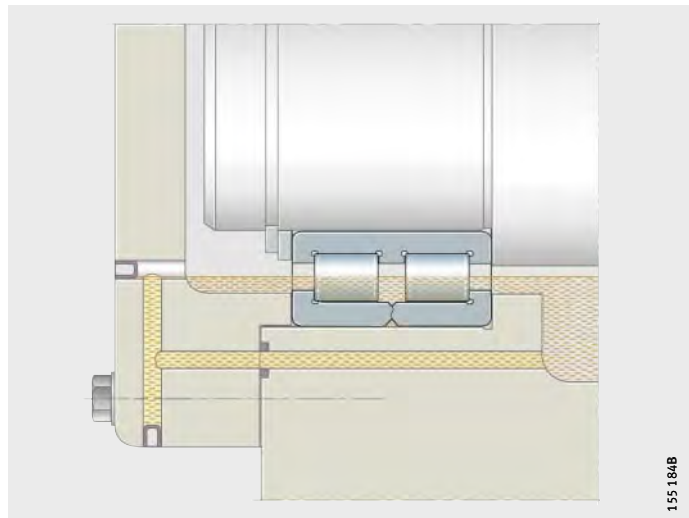

Figure 2
Oil bath lubrication (schematic)



When using oil bath lubrication, venting of the housing is absolutely necessary. For example, the filling hole can be closed off using a bleed screw.

Lubrication

Recirculating oil lubrication

In recirculating oil lubrication, the oil is subjected to additional cooling, *Figure 3*. It can therefore dissipate heat from the bearing. In addition, contaminant and wear particles can be flushed out of the bearing. It is always recommended that the oil circuit is fitted with a filter.

- ① Filter
- ② Pump
- ③ Cooling system

Figure 3
Recirculating oil lubrication
(schematic)

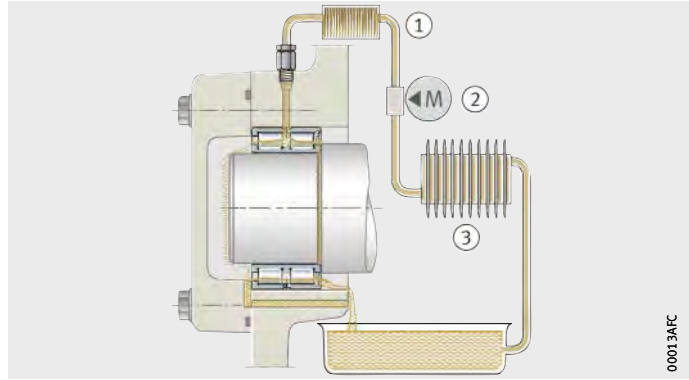

Oil selection

For the lubrication of rolling bearings, mineral oils and synthetic oils are essentially suitable.

Oils with a mineral oil base are used most frequently. They must fulfil at least the requirements according to DIN 51517 or DIN 51524.

Special oils, often synthetic oils, are used under extreme operating conditions or where there are special requirements relating to oil resistance. In these cases, please consult the lubricant manufacturers or the Schaeffler engineering service.

Further information

- TPI 176, Lubrication of Rolling Bearings.



Load carrying capacity

Load carrying capacity of split and unsplit plummer block housings

- The permissible load on plummer block housings is dependent on:
- the strength of the housing
 - the load carrying capacity of the bearing
 - the load direction
 - the strength of the connecting screws (in split plummer block housings).

Rupture loads

Guide values are indicated for the housing rupture load of some housing series. Where housings are available in different material variants, it must be noted that the rupture load is dependent on the housing material.

In the case of split plummer block housings, guide values are also indicated for the maximum load carrying capacity of the screws connecting the upper and lower sections of the housing. The guide values are indicated as a function of the load direction, *Figure 1*. The guide values are valid for purely static loading.

The values in the rupture load table apply if the flatness of the mounting surface in accordance with DIN EN ISO 1101 corresponds to tolerance grade IT7 in accordance with DIN EN ISO 286-1 (measured across the diagonal). A precondition for supporting loads is that the housing base surface is completely and rigidly supported.

Figure 1
Load directions F for the guide values for the housing rupture load and the maximum load carrying capacity of the connecting screws

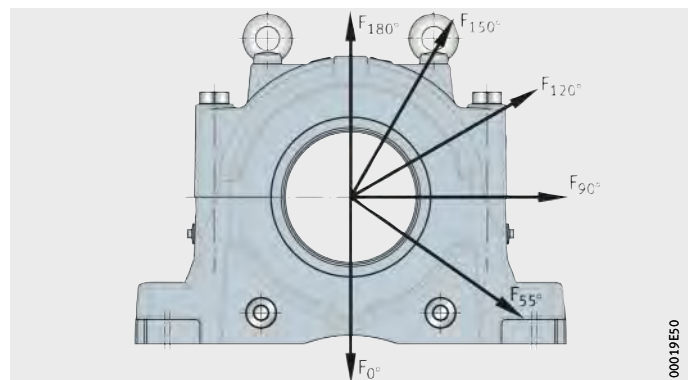

Load carrying capacity

- Permissible load** The permissible load on the housing and the connecting screws and eye bolts must not be exceeded.
- Safety factors** When determining the permissible load, safety factors must be applied. For general machine building, a safety factor of 6 is normally applied to the housing rupture load. For split plummer block housings SNS, a safety factor of 5 is sufficient.
- Axial load** Where axial load is present or a radial load does not act vertically, it is recommended that the housing should be secured horizontally by means of stops or dowels, see page 43.
-  If the housing is subjected to axial load, the permissible axial load of the bearing fitted must be taken into consideration. If the bearing is located on the shaft using an adapter sleeve, the axial retaining force of the bearing and adapter sleeve must also be taken into consideration.
- Connecting screws** Where split plummer block housings are used, the guide values for the maximum load carrying capacity of the connecting screws must also be observed. Depending on the application, these may be the limiting factor for the load carrying capacity of the housing.
- Eye bolts** If the eye bolts provided are used to lift housings or housing components, their permissible load must be observed, see section Eye bolts, page 39.



Mounting and dismounting

Fundamental specifications

The correct mounting of rolling bearings and housings has a decisive influence on the achievable bearing life. Careful attention must therefore be paid to the following guidelines.

In the interests of the user, the applicable legal regulations and other directives relating to environmental protection and occupational safety must be observed.

Cleanliness

Cleanliness is a fundamental precondition for the successful mounting of rolling bearings and housings.



Contamination can shorten the operating life of rolling bearings and must therefore be prevented.

Measures

Measures for ensuring cleanliness are as follows:

- Ensure that the mounting area is clean.
- Clean the mounting surface.
- Clean the housing, seals and cover, paying particular attention to any machining or moulding sand residues.
- Only use volatile solvents and lint-free cloths for cleaning.
- Do not remove rolling bearings and adapter sleeves or withdrawal sleeves from their packaging until immediately before mounting. Do not remove the anti-corrosion protection on these components.

Eye bolts

On many housings, the housing body is provided with one or two eye bolts to DIN 580. These are intended as locating points for mounting and dismounting of the housing. The load carrying capacity of the eye bolts allows lifting of the housing including, in many cases, a bearing fitted in the housing, but without a shaft. Further relevant information is given in the description of the specific housing.

Split plummer block housings KPG and KPGZ have additional eye bolts on the covers. These eye bolts must not be used for lifting of the housing but only for lifting of the covers.



Rupture of the eye bolts due to overload. Severe personal injury or damage to property as a result of the falling housing or housing parts.

Mounting and dismounting

Correct usage of eye bolts on the housing body

Specifications for the use of eye bolts as locating points, *Figure 1*:

- Eye bolts must always be screwed fully into the housing.
- If several eye bolts are provided on the housing body, all the eye bolts must be used simultaneously as locating points.
- Only use eye bolts for lifting the housing and, if permitted for this housing, the bearing fitted in the housing. The eye bolts must not be subjected to additional load as a result of parts attached to the housing.

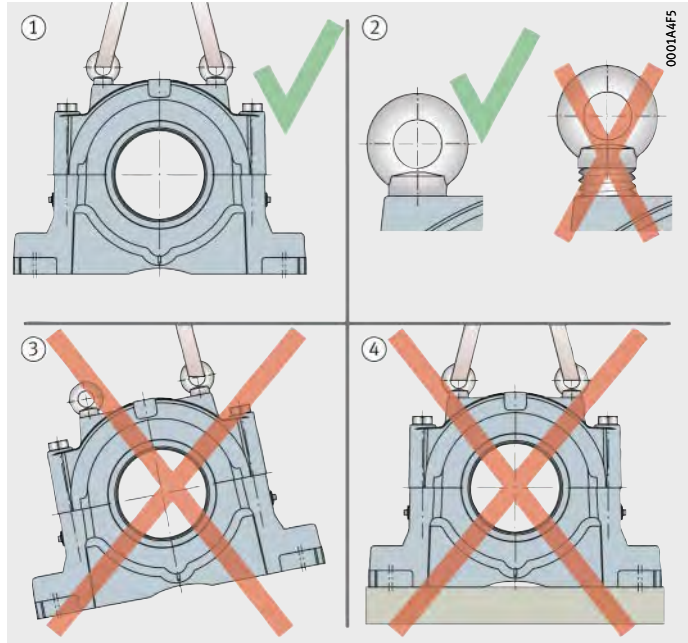

- ① Correct usage of eye bolts as locating points
- ② Screw in eye bolts completely
- ③ Always use all eye bolts simultaneously
- ④ Do not apply additional load as a result of attached parts

Figure 1
Correct usage of eye bolts on the housing body



Location of housings

The essential preconditions for the secure location of bearing housings are suitable mounting surfaces, the correct selection and use of foot screws as well as, in certain cases, additional horizontal location of the housing.

Surface quality of the mounting surface

The requirements for the surface on which the housing is to be mounted are as follows:

- sufficiently robust to withstand the static and dynamic loads occurring in operation over the long term
- surface roughness: $R_{max} 12,5$
- flatness of the mounting surface in accordance with DIN EN ISO 1101 corresponding to tolerance grade IT7 in accordance with DIN EN ISO 286-1 (measured across the diagonal).
- free from colour.

Level of mounting surfaces

A difference in level between the mounting surfaces of bearing housings will lead to misalignment of the shaft, *Figure 2*.

ψ = misalignment of shaft
h = difference in level between mounting surfaces

Figure 2
Misalignment of the shaft

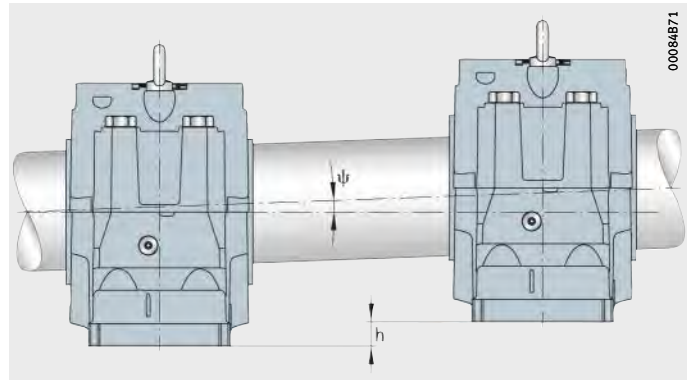

The permissible misalignment is dependent on the housing and seal variant. Differences in level must be compensated such that the permissible misalignment is not exceeded. Levelling shims can be used for this purpose.

In addition, it must be ensured that the bearings mounted can compensate the misalignments present.

Mounting and dismounting

Tightening torques for foot screws

Foot screws are used for screw mounting the housing to the mounting surface. They are not included in the scope of delivery of the housings.

The following table contains tightening torques for metric coarse pitch threads in accordance with DIN 13, DIN 962 and DIN ISO 965-2 as well as head contact dimensions in accordance with DIN EN ISO 4014, DIN EN ISO 4017, DIN EN ISO 4032, DIN EN ISO 4762, DIN 6912, DIN 7984, DIN 7990 and DIN EN ISO 8673.

The maximum tightening torques are valid with 90% utilisation of the yield stress of the screw material 8.8 and a friction factor of 0,14. We recommend that foot screws should be tightened to approx. 70% of these values, see table.

Tightening torques for foot screws with metric thread in accordance with DIN 13, DIN 962 and DIN ISO 965-2

Nominal screw diameter	Maximum tightening torque Nm	Recommended tightening torque Nm
M6	11,3	8
M8	27,3	20
M10	54	35
M12	93	65
M16	230	160
M20	464	325
M24	798	550
M30	1 597	1 100
M36	2 778	1 950
M42	3 991	2 750
M48	6 021	4 250
M56	9 650	6 750
M64	14 416	10 000
M72	21 081	14 500
M80	29 314	20 500
M90	42 525	29 500
M100	59 200	41 000



Horizontal location

In the case of plummer block housings, it may be necessary to supplement the foot screws by additional horizontal location of the housing.

Such horizontal location is necessary if one of the following conditions is fulfilled:

- The load angle is between 55° and 120° , *Figure 3*.
- Axial load is present.

Depending on the housing, the location may be implemented by means of stops in the load direction or pins.

① Load angle range within which horizontal location of the housing is necessary

Figure 3
Load directions on a plummer block housing

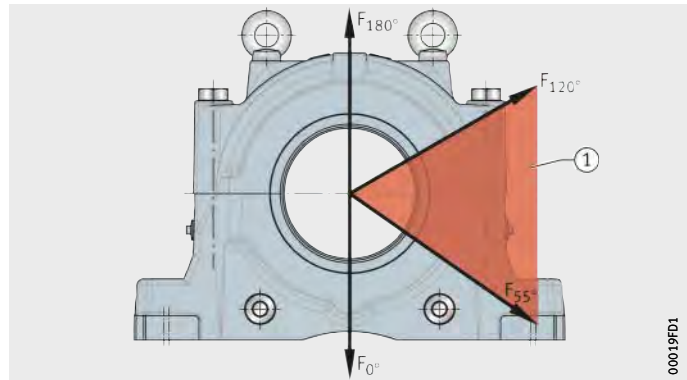

Mounting and dismounting

Location of bearings on the shaft

Complete mounting of a bearing housing also always includes the fitting of the bearing.

Bearing seats on the shaft

The bearing seats on the shaft must be free from impact marks and burrs and must have adequate dimensional and geometrical accuracy.

The requirements for dimensional and geometrical accuracy of the bearing seats for a tapered bearing bore and location by means of an adapter sleeve, withdrawal sleeve or adjustment sleeve are as follows:

- The diameter is at least in the tolerance class h9 $\text{\textcircled{E}}$ and preferably h8 $\text{\textcircled{E}}$.
- The cylindricity in accordance with DIN EN ISO 1101 is within IT5/2.

The requirements for dimensional and geometrical accuracy of the bearing seats for a cylindrical bearing bore and direct seating of the bearing on the shaft are dependent on the operating conditions.

Hydraulic method

The mounting and dismounting of large bearings requires high mounting forces and is made easier by using the hydraulic method.

The sleeves that can be used for the hydraulic method are as follows:

- adapter sleeves with oil slots on the tapered outside surface and a pump connector on the thread side. These adapter sleeves have the suffix HG.
- withdrawal sleeves with oil slots on the tapered outside surface and two pump connectors on the thread side offset from each other by 90°. These withdrawal sleeves have the suffix H.

For a shaft diameter of or more than 150 mm, we recommend use of the hydraulic method in order to facilitate mounting.

Spherical roller bearings with tapered bore and adapter sleeve

The bearings used frequently in FAG bearing housings are spherical roller bearings with a tapered bore that are located on the shaft using an adapter sleeve.

The adapter sleeve is slid onto the shaft first and the bearing is then slid onto the taper of the adapter sleeve. As a result, the radial internal clearance of the bearing is reduced. At the same time, a radial preload occurs between the bearing inner ring, adapter sleeve and shaft, ensuring the rigid seating of the bearing on the shaft.

FAG hydraulic nuts can be used to aid the pressing-on operation. The reduction in the radial internal clearance is determined in the case of spherical roller bearings by measurement of the residual clearance using feeler gauges or by measurement of the drive-up distance.

The values given for the reduction in the radial internal clearance and the drive-up distance on the taper lead to rigid seating of the bearing on the shaft, see table, page 45.



**Reduction
in the radial internal clearance and
drive-up distance on the taper 1:12**

Nominal bearing bore diameter		Reduction in radial internal clearance		Drive-up distance on taper 1:12				Minimum radial internal clearance after mounting, control value for		
d				Shaft		Sleeve		Group N	Group 3	Group 4
mm		mm		mm		mm		mm	mm	mm
over	incl.	min.	max.	min.	max.	min.	max.	min.	min.	min.
24	30	0,015	0,02	0,3	0,35	0,3	0,4	0,015	0,02	0,035
30	40	0,02	0,025	0,35	0,4	0,35	0,45	0,015	0,025	0,04
40	50	0,025	0,03	0,4	0,45	0,45	0,5	0,02	0,03	0,05
50	65	0,03	0,04	0,45	0,6	0,5	0,7	0,025	0,035	0,055
65	80	0,04	0,05	0,6	0,75	0,7	0,85	0,025	0,04	0,07
80	100	0,045	0,06	0,7	0,9	0,75	1	0,035	0,05	0,08
100	120	0,05	0,07	0,7	1,1	0,8	1,2	0,05	0,065	0,1
120	140	0,065	0,09	1,1	1,4	1,2	1,5	0,055	0,08	0,11
140	160	0,075	0,1	1,2	1,6	1,3	1,7	0,055	0,09	0,13
160	180	0,08	0,11	1,3	1,7	1,4	1,9	0,06	0,1	0,15
180	200	0,09	0,13	1,4	2	1,5	2,2	0,07	0,1	0,16
200	225	0,1	0,14	1,6	2,2	1,7	2,4	0,08	0,12	0,18
225	250	0,11	0,15	1,7	2,4	1,8	2,6	0,09	0,13	0,2
250	280	0,12	0,17	1,9	2,6	2	2,9	0,1	0,14	0,22
280	315	0,13	0,19	2	3	2,2	3,2	0,11	0,15	0,24
315	355	0,15	0,21	2,4	3,4	2,6	3,6	0,12	0,17	0,26
355	400	0,17	0,23	2,6	3,6	2,9	3,9	0,13	0,19	0,29
400	450	0,2	0,26	3,1	4,1	3,4	4,4	0,13	0,2	0,31
450	500	0,21	0,28	3,3	4,4	3,6	4,8	0,16	0,23	0,35
500	560	0,24	0,32	3,7	5	4,1	5,4	0,17	0,25	0,36
560	630	0,26	0,35	4	5,4	4,4	5,9	0,2	0,29	0,41
630	710	0,3	0,4	4,6	6,2	5,1	6,8	0,21	0,31	0,45
710	800	0,34	0,45	5,3	7	5,8	7,6	0,23	0,35	0,51
800	900	0,37	0,5	5,7	7,8	6,3	8,5	0,27	0,39	0,57
900	1000	0,41	0,55	6,3	8,5	7	9,4	0,3	0,43	0,64
1000	1120	0,45	0,6	6,8	9	7,6	10,2	0,32	0,48	0,7
1120	1250	0,49	0,65	7,4	9,8	8,3	11	0,34	0,54	0,77
1250	1400	0,55	0,72	8,3	10,8	9,3	12,1	0,36	0,59	0,84

Further information

- Detailed information on mounting of bearings: MH 1, Mounting Handbook.
- Online help and calculation tool for the mounting of bearings: <http://mountingmanager.schaeffler.com>.
- Products and services for mounting: Catalogue IS 1, Mounting and Maintenance of Rolling Bearings.
- Questions about the mounting operation: industrial-services@schaeffler.com.

Mounting and dismounting

Maintenance

Careful maintenance of a housing in conjunction with monitoring of the operating condition of the bearing position makes a significant contribution towards achieving a long operating life and reliable operation.

Regular maintenance must be carried out and the intervals for the various maintenance operations are dependent on the ambient and operating conditions.



Only carry out maintenance operations when the machine is at a standstill.

Take precautions to prevent unintentional startup of the machine.

Regular maintenance work

Regular maintenance operations on bearing housings are as follows:

- checking of the alignment of the housing
- retightening of the foot screws and connecting screws.
This should be carried out more frequently at first after commissioning and at longer intervals later
- inspection of the housing for damage. Any indications such as conspicuous noises or unusual escape of grease must also be noted
- relubrication of the seals. Some seals are equipped for this purpose with lubrication nipples. If the ambient air contains high levels of dust, the seals must be relubricated more frequently
- relubrication of the bearings fitted. The grease is introduced into the housing via lubrication nipples and thus travels to the bearing. During relubrication, it must be possible for excess grease to escape via non-contact seals or opened grease outlet holes
- cleaning of the housing to remove baked-on material and other coarse contaminants.



If cleaning is not carried out correctly, contamination or moisture may enter the housing.

In the area of the seals in particular, do not use compressed air, steam cleaners or comparable cleaning methods.



Special solutions

Special solutions for standard housings

FAG standard housings are designed as split and unsplit plummer block housings, as take-up housings and as flanged housings. These housings offer versatile configuration possibilities and thus cover a wide spectrum of applications.

In addition, it is possible to supply other non-standard variants of these housings or to expand the scope of delivery where:

- special technical requirements are present
- the customer has particular specifications that must be fulfilled.

Special solutions and additional services

The special solutions and additional services described below are available by agreement.

Tolerance class of bearing seat

Tolerance class of bearing seat in accordance with customer specification, for example:

- G6
- H6
- F7
- G7
- K7
- N7.

High temperature seals

High temperature seals instead of felt seals, giving expanded operating limits:

- temperature resistance up to +300 °C
- circumferential velocity up to 20 m/s.

Coating colour

Coating colour other than the standard coating of the housing, such as:

- RAL 1015, light ivory
- RAL 3000, flame red
- RAL 5015, sky blue
- RAL 5018, turquoise blue
- RAL 7043, traffic grey B.

Lubrication nipples

Supply of lubrication nipples or parts for closing off relubrication holes, where these deviate from the standard scope of delivery.

Special solutions

Long term packaging Long term packaging of housings allows a storage time from 3 up to 10 years, depending on the preservation selected and the climatic conditions. The storage regulations must be observed.
Long term packaging is available for housings with a mass of 30 kg or heavier.

Acceptance inspection of products Acceptance inspection of products by the customer can be carried out directly on site. The acceptance documents and inspection certificates can be prepared in accordance with FAG specifications or customer specifications.

Acceptance inspection certificate Preparation of an acceptance inspection certificate 3.1 in accordance with DIN EN 10204.

Special solutions for plummer block housings SNV Special solutions available specifically for split plummer block housings SNV include:

- housing design for oil lubrication
- additional holes for fixing screws and pins.

FAG



Split plummer block housings

SNV

S30

SNS

RLE

KPG, KPGZ

LOE

Split plummer block housings

Split plummer block housings SNV	52
	Plummer block housings SNV are suitable for a wide range of applications. The main dimensions correspond to ISO 113 and DIN 736 to DIN 739. They can be fitted with spherical roller bearings, barrel roller bearings and self-aligning ball bearings.	
Split plummer block housings S30	130
	Plummer block housings S30 are suitable for a wide range of applications and their main dimensions correspond to ISO 113. They can be fitted with spherical roller bearings 230 with a tapered bore and adapter sleeve and with a cylindrical bore.	
Split plummer block housings SNS	146
	Plummer block housings SNS are highly robust housings and ideally suitable for aggressive environmental conditions such as those in mining applications. The main dimensions conform to ISO 113. They can be fitted with spherical roller bearings with a tapered bore and adapter sleeve and with a cylindrical bore.	
Split plummer block housings RLE	214
	Split plummer block housings RLE were developed specifically for the bearing arrangements of back-up rollers. Suitable bearings are spherical roller bearings 241 with a tapered bore and withdrawal sleeve and with a cylindrical bore.	
Split plummer block housings KPG, KPGZ	228
	Split plummer block housings KPG and KPGZ are used in trunnion bearing arrangements on converters for steel production. The housings are matched to spherical roller bearings 249 with a tapered bore and adjustment sleeve (KPG) and with a cylindrical bore (KPGZ).	
Split plummer block housings LOE	246
	These housings are designed for oil lubrication and are particularly suitable for bearing arrangements running at high speeds. Where necessary, housings with an integrated cooling coil can be ordered. Spherical roller bearings with a tapered bore and adapter sleeve are fitted.	

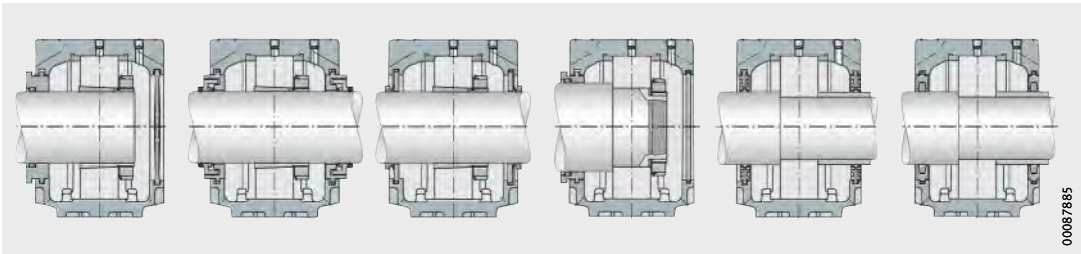

00087885

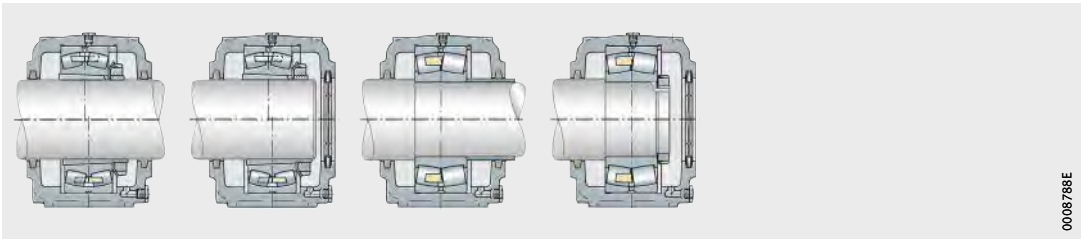

0008788E

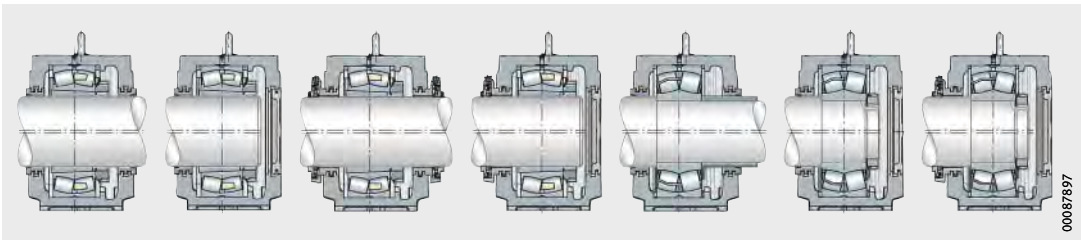

00087897

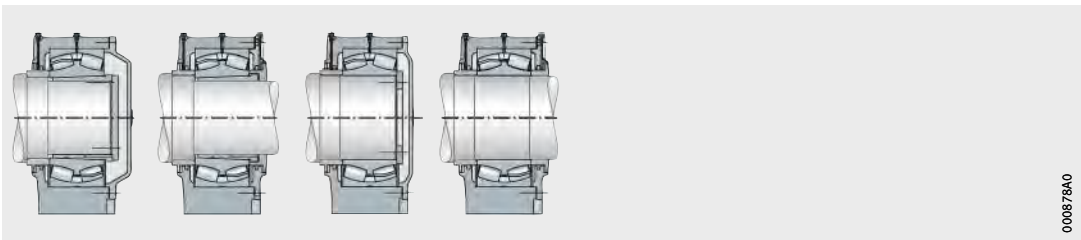

000878A0

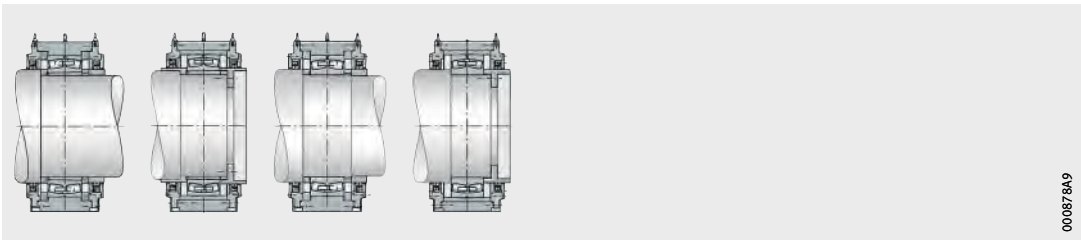

000878A9

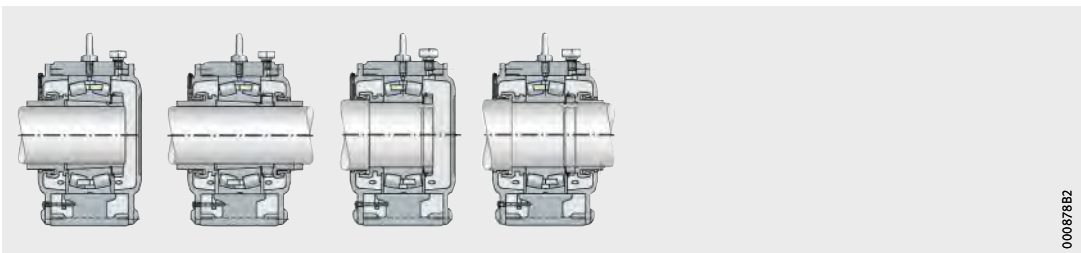

000878B2

FAG



Split plummer block housings SNV

Split plummer block housings SNV

		Page
Product overview	Split plummer block housings SNV	54
Features	Modular concept	56
	Dimensions and interchangeability	56
	Suitable bearings	56
	Housing materials and anti-corrosion protection	57
	Locating and non-locating bearings	57
	Seals and covers	58
	Housing configurations.....	62
	Lubrication	64
	Designation structure	71
	Ordering examples	74
Design and safety guidelines	Load carrying capacity	75
	Eye bolts	77
	Foot screws	77
Accuracy	77
Dimension tables	Plummer block housings SNV, split, for bearings with tapered bore and adapter sleeve, metric shaft.....	78
	Plummer block housings SNV, split, for bearings with cylindrical bore, metric shaft.....	88
	Plummer block housings SNV, split, for bearings with tapered bore and adapter sleeve, inch size shaft	102



Product overview Split plummer block housings SNV

Plummer block housings Split

SNV
(SNV052 to SNV200)

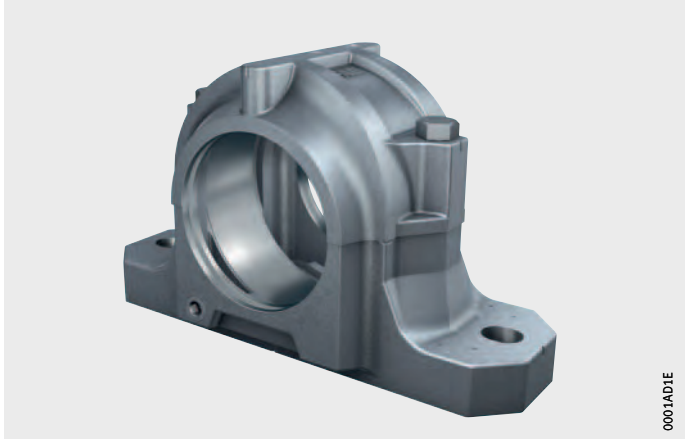

0001AD1E

SNV
(SNV215 to SNV340)



0001AD1F

Accessories Labyrinth seals Taconite seals

TSV



0007EEBA

TCV



0001AD2B

**Double lip seals
V ring seals**

DH



DHV



Felt seals

FSV



Covers
Plastic, usable up to +120 °C
Steel and FKM, usable up to +200 °C

DKV



DKVT

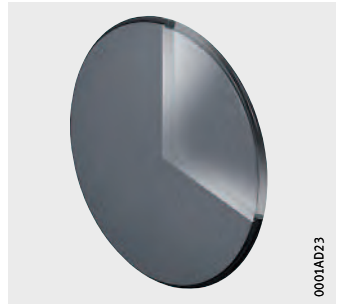

Locating rings

FRM



Split plummer block housings SNV

Features Split FAG plummer block housings SNV and the associated bearings form bearing arrangement units that can be matched, through the appropriate selection of accessories, to a wide range of applications. Applications include agricultural machinery, the paper processing industry, mining, materials processing, the steel industry and power stations.

Modular concept The housings are designed in accordance with a modular concept. Each housing can be fitted with rolling bearings of various diameter and width series if they have the correct outside diameter for the housing.

Depending on their design, the bearings can be located either directly on the shaft or by means of an adapter sleeve. This gives different shaft diameters for the same bearing size. The spacings between the shaft and housing body are compensated by means of appropriately matched seals.

Dimensions and interchangeability The dimensions of the housings SNV correspond to ISO 113 and DIN 736 to DIN 739. The housings SNV are interchangeable with the existing housings SN and SNE.

Suitable bearings Split plummer block housings SNV are suitable for fitting with spherical roller bearings, barrel roller bearings and self-aligning ball bearings with a tapered or cylindrical bore as well as deep groove ball bearings, see table. The range of shaft diameters is 20 mm to 160 mm and $\frac{3}{4}$ inch to $5\frac{1}{2}$ inch.

Bearing types and sizes

Bearing type	Size
Spherical roller bearings ■ with tapered bore and adapter sleeve	21307..-K to 21322..-K
	22205..-K to 22232..-K
	22308..-K to 22332..-K
	23218..-K to 23232..-K
■ with cylindrical bore	21304 to 21322
	22205 to 22232
	22308 to 22332
	23218 to 23232
Self-aligning ball bearings ■ with tapered bore and adapter sleeve	1205-K to 1222-K
	1305-K to 1320-K
	2205-K to 2220-K
	2305-K to 2320-K
■ with cylindrical bore	1205 to 1222
	1305 to 1320
	2205 to 2220
	2304 to 2320

Bearing types and sizes (continued)

Bearing type	Size
Barrel roller bearings	20205-K to 20232-K
■ with tapered bore and adapter sleeve	20305-K to 20332-K
■ with cylindrical bore	20205 to 20232
	20305 to 20330
Deep groove ball bearings	6205 to 6232
■ with cylindrical bore	6304 to 6332



Split spherical roller bearings

Unsplit spherical roller bearings with an adapter sleeve can be replaced by split spherical roller bearings. This gives a considerable reduction in the work associated with bearing replacement in numerous applications.

In order to ensure selection of the correct combination of housing and bearing, please contact us.

Further information

■ WL 43165, Split Spherical Roller Bearings.

Housing materials and anti-corrosion protection

The standard material for the housing bodies is flake graphite cast iron EN-GJL-HB215 in accordance with DIN EN 1561 (suffix L). By agreement, housing bodies made from spheroidal graphite cast iron EN-GJS-400-15 in accordance with DIN EN 1563 (suffix D) are available.

All outer surfaces not machined by chip-forming methods have a universal paint coating (colour RAL 7031, bluish-grey). The coating can be finished using all synthetic resin, polyurethane, acrylic, epoxy resin, chlorinated rubber, nitrocellulose and acid-hardening hammer tone finishes.

Inner and outer surfaces machined by chip-forming methods are provided with anti-corrosion protection that can be easily removed. It is recommended that only volatile solvents and lint-free cloths should be used.

Locating and non-locating bearings

The bearing seats in the housing are machined such that the bearings are movable in the housing and can thus function as non-locating bearings. Locating bearing arrangements can be achieved by the insertion of one locating ring FRM on each side of the bearing outer ring. The bearing is thus seated in the centre of the housing. Locating rings must be ordered separately.

Split plumber block housings SNV

Seals and covers	<p>For sealing of the bearing housings, the standard seals available are the labyrinth seal, the Taconite seal, the double lip seal, the V ring seal and the felt seal. These seals are matched to the rectangular section annular slots on both sides of the housings. They are principally suitable for grease lubrication.</p> <p>The seals must be ordered separately. They are supplied individually. If a continuous shaft is present, two seals must be ordered. Special seals are also available by agreement.</p>
Labyrinth seals TSV	<p>Labyrinth seals TSV give non-contact sealing. They are therefore suitable for high circumferential velocities. The O ring made from fluoro rubber FKM pressed between the labyrinth ring and shaft is suitable for temperatures up to +200 °C.</p> <p>The labyrinth seal allows shaft misalignment of up to 0,5° in both directions.</p> <p>If necessary, the labyrinth can be relubricated. For this purpose, a lubrication hole must be made in the upper housing section for each labyrinth seal. The optimum positions are indicated by cast-in pilot holes.</p>
Taconite seals TCV	<p>Taconite seals TCV are combined seals comprising a labyrinth seal and a V ring. These seals are suitable for extreme operating conditions in relation to contamination and dust. The V ring is made from NBR and is suitable for temperatures up to +100 °C.</p> <p>The Taconite seal allows shaft misalignment of up to 0,5° on both sides.</p>
Double lip seals DH	<p>The seal lips of the double lip seal DH slide on the rotating shaft. The outer seal lip prevents ingress of contamination into the bearing. This effect is supported by the grease inserted between the seal lips. The inner lip prevents lubricant from escaping from the housing.</p> <p>The seal is made from acrylonitrile butadiene rubber NBR and is suitable for circumferential velocities of up to 13 m/s. For continuous operation, a maximum circumferential velocity of 6 m/s is recommended.</p> <p>The seal is suitable for temperatures from -40 °C to +100 °C. It allows shaft misalignment of up to 0,5° in both directions.</p>

The double lip seal DH is a two-piece seal. It can be easily inserted in the annular slots in the housing. The parting joint of the seal halves should be in the same plane as the parting joint of the housing.

The contact running area on the shaft for the seal lips should have a roughness Ra 3,2.



V ring seal DHV

In the case of V ring seals DHV, the seal lip is in axial contact with the sliding surface which is located in the rectangular section annular slot of the housing.

The seal is made from NBR and is suitable, when using grease lubrication, for circumferential velocities of up to 12 m/s. If circumferential velocities of more than 8 m/s are present, axial location is necessary. The seal allows shaft misalignment of up to 0,5° in both directions.



Felt seals FSV

The seals are suitable for circumferential velocities of up to 5 m/s and, after running-in, up to 15 m/s. They can be used at temperatures up to +100 °C. By agreement, aramide packing is available for high temperatures.

The permissible shaft misalignment is 0,5° in both directions.

Felt seals FSV are particularly suitable for grease lubrication. They comprise an adapter holding the inserted, oil-impregnated felt strip and the adapter is secured against rotation by an O ring in the annular slot in the housing.

Covers DKV

Covers are used in the case of housings closed on one side. The covers fit in the rectangular section annular slots in the housings. Covers DKV are made from plastic and are suitable for long term temperatures of up to +120 °C.

The covers must be ordered separately.

Cover DKVT

Covers DKVT are made from steel, flake graphite cast iron or spheroidal graphite cast iron and are suitable for temperatures of up to +200 °C. They are supplied by agreement.

Characteristics and operating limits

The characteristics and operating limits of the standard seals and covers are compared in an overview, see table, page 60.

Split plummer block housings SNV

Standard seals and covers for plummer block housings SNV

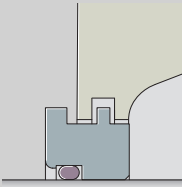
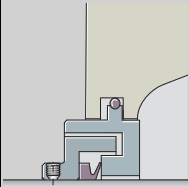
Seals and covers	Labyrinth seal	Taconite seal	
			
Designation	TSV	TCV	
Material	Steel, FKM	Steel, NBR	
Pieces per pack	1	1	
Suitability for sealing against			
Dust	+	++	
Fine solid particles	+	++	
Coarse solid particles	+	++	
Slivers	++	++	
Spray liquids	-	++	
Operating limits			
Long term temperature	°C	-20 to +200 (due to FKM)	-30 to +100 (due to NBR)
	°F	-4 to +390 (due to FKM)	-22 to +210 (due to NBR)
Circumferential velocity	m/s	No restriction	≤ 12
Misalignment	°	≤ 0,5	≤ 0,5
Low friction		++	+
Axial shaft displacement (suitability as non-locating bearing)		+	+
Vertical arrangement		-	-
Suitability for grease relubrication		+	+
Suitability for oil lubrication		-	-
Compatibility with sunlight		++	++
Preconditions			
Tolerance class ¹⁾ of shaft diameter		h8 (h9)	h8 (h9)
Shaft roughness	µm	Ra3,2	Ra3,2

- ++ Highly suitable
- + Suitable
- (+) Suitable with restrictions
- Not suitable

1) The envelope condition © applies here.

Double lip seal	V ring seal	Felt seal	Cover	
DH	DHV	FSV	DKV	DKVT
NBR	Steel, NBR	Steel, felt, NBR	Plastic	Steel or cast iron, FKM
1	1	1	1	1
++	+	+	+	+
++	+	-	+	+
+	-	-	+	+
+	-	+	+	+
+	+	-	+	+
-40 to +100 (due to NBR)	-30 to +100 (due to NBR)	-30 to +100 (due to NBR)	-40 to +120	-20 to +200 (due to FKM)
-40 to +21 (due to NBR)	-22 to +210 (due to NBR)	-22 to +210 (due to NBR)	-40 to +250	-4 to +390 (due to FKM)
max. 13 (duration 6)	max. 12	5 (after running-in 15)	Not applicable	Not applicable
≤ 0,5	≤ 0,5	≤ 0,5	Not applicable	Not applicable
++	++	-	Not applicable	Not applicable
++	(+)	++	Not applicable	Not applicable
+	(+)	-	+	+
++	(+)	-	+	++
(+)	-	-	-	++
+	-	++	(+)	++
h8 (h9)	h8 (h9)	h8 (h9)	Not applicable	Not applicable
Ra3,2	Ra3,2	Ra3,2	Not applicable	Not applicable



Split plummer block housings SNV

Housing configurations

The modular structure of plummer block housings SNV facilitates numerous possible combinations, *Figure 1* and *Figure 2*, page 63.

On the basis of the standard components, the following features can be varied in the housing configuration:

- location of bearings with a tapered bore by means of an adapter sleeve on a shaft of constant diameter or of bearings with a cylindrical bore directly on a stepped shaft
- sealing of the housing by means of a labyrinth seal, Taconite seal, double lip seal, V ring seal or felt seal
- continuous shaft or a housing closed on one side
- cover made from plastic (DKV) or cover made from steel or cast iron (DKVT)
- design of the bearing arrangement as a locating bearing arrangement or a non-locating bearing arrangement.
- spherical roller bearing in a split or unsplit design.

-
- ① Locating bearing
② Non-locating bearing
③ Labyrinth seal TSV
④ Cover DKV
⑤ Cover DKVT
⑥ Taconite seal TCV
⑦ Double lip seal DH
⑧ V ring seal DHV
⑨ Felt seal FSV

Figure 1
Plummer block housings SNV
for bearings with tapered bore
and adapter sleeve
(overview of combinations)

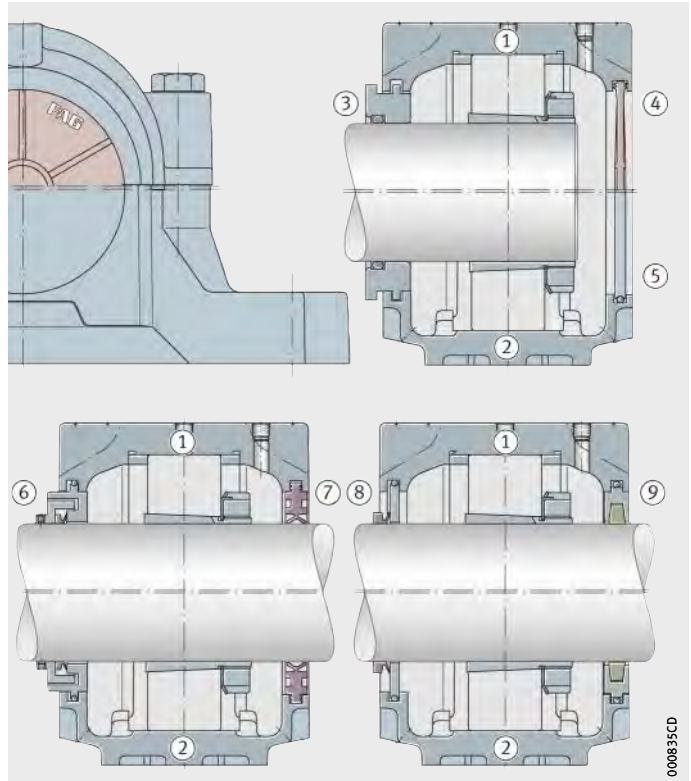

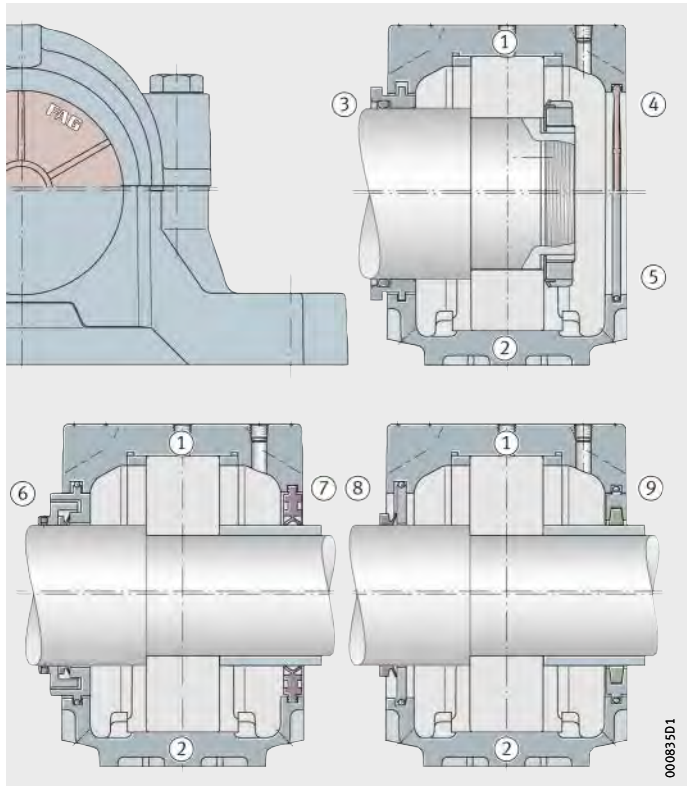

- ① Locating bearing
- ② Non-locating bearing
- ③ Labyrinth seal TSV
- ④ Cover DKV
- ⑤ Cover DKVT
- ⑥ Taconite seal TCV
- ⑦ Double lip seal DH
- ⑧ V ring seal DHV
- ⑨ Felt seal FSV

Figure 2
Plummer block housings SNV
for bearings with cylindrical bore
(overview of combinations)

Mounting of split spherical roller bearings

In the case of plummer block housings SNV, an unsplit spherical roller bearing with a tapered bore and adapter sleeve can be replaced by a split spherical roller bearing, *Figure 3*.

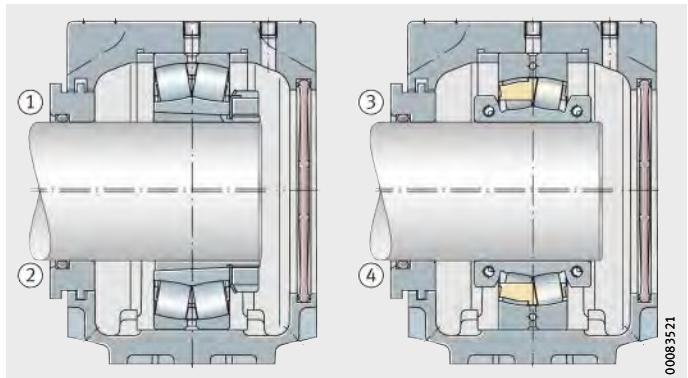

- ① Locating bearing with unsplit bearing
- ② Non-locating bearing with unsplit bearing
- ③ Locating bearing with split bearing
- ④ Non-locating bearing with split bearing

Figure 3
Plummer block housings SNV
with split and unsplit
spherical roller bearing

Split plummer block housings SNV

Lubrication Split plummer block housings SNV are principally intended for grease lubrication. The housings can, however, also be supplied in a design for oil lubrication.

Greases In the case of bearing operating temperatures $< +100\text{ °C}$, bearing loads $P/C < 0,3$ and a bearing-specific speed parameter $k_f \cdot n \cdot d_M < 700\,000\text{ min}^{-1} \cdot \text{mm}$ ($k_f = 1$ for self-aligning ball bearings and deep groove ball bearings, $k_f = 8$ to $10,5$ for spherical roller bearings), the most suitable grease is Arcanol MULTITOP, a lithium soap grease of NLGI grade 2 with particularly effective EP additives.

Due to their favourable flow behaviour, greases of NLGI grade 2, such as Arcanol MULTITOP and Arcanol MULTI2, are more suitable for relubrication than greases of higher consistency grades.

Grease quantities

For initial greasing, the basic rule is that the bearing should be filled with grease to 100% and the free volume of the housing to 60%. This is the basis for the recommended grease quantities, see table. The free volume is the space that remains in the housing once the bearing, adapter sleeve, shaft and seals have been fitted. For relubrication, minimum quantities of grease are recommended.



Recommended grease quantities for initial greasing and relubrication

Housing	Grease quantity	
	Initial greasing ≈ g	Relubrication (minimum quantity) ≈ g
SNV052-F	30	5
SNV062-F	45	5
SNV072-F	65	10
SNV080-F	80	10
SNV085-F	105	10
SNV090-F	130	10
SNV100-F	180	15
SNV110-F	210	15
SNV120-F	270	20
SNV125-F	290	20
SNV130-F	330	20
SNV140-F	440	25
SNV150-F	500	30
SNV160-F	650	40
SNV170-F	700	45
SNV180-F	900	55
SNV190-F	950	60
SNV200-F	1 200	70
SNV215-F	1 400	80
SNV230-F	1 600	85
SNV240-F	1 700	90
SNV250-F	2 000	100
SNV260-F	2 000	120
SNV270-F	2 500	130
SNV280-F	2 600	140
SNV290-F	3 000	150
SNV300-F	3 100	160
SNV320-F	3 700	200
SNV340-F	4 500	240

For a speed parameter $n \cdot d_M < 50\,000 \text{ min}^{-1} \cdot \text{mm}$ and a non-contact seal (labyrinth seal TSV), where the grease should also perform a sealing function, the housing and seal cavities should be filled to 100%.

Split plummer block housings SNV

Relubrication

Where relubrication is carried out on bearings with a circumferential lubrication groove, the grease is introduced into the housing via the central lubrication hole, *Figure 4*, ③. In this type of relubrication, the grease acts directly on the bearing raceway.

Where relubrication is carried out on bearings without a circumferential lubrication groove, the grease is introduced laterally into the housing, *Figure 4*, ④. In this case, the housing cavities on the side with the lubrication nipple must be filled completely with grease so that the relubrication grease can act immediately on the bearing.

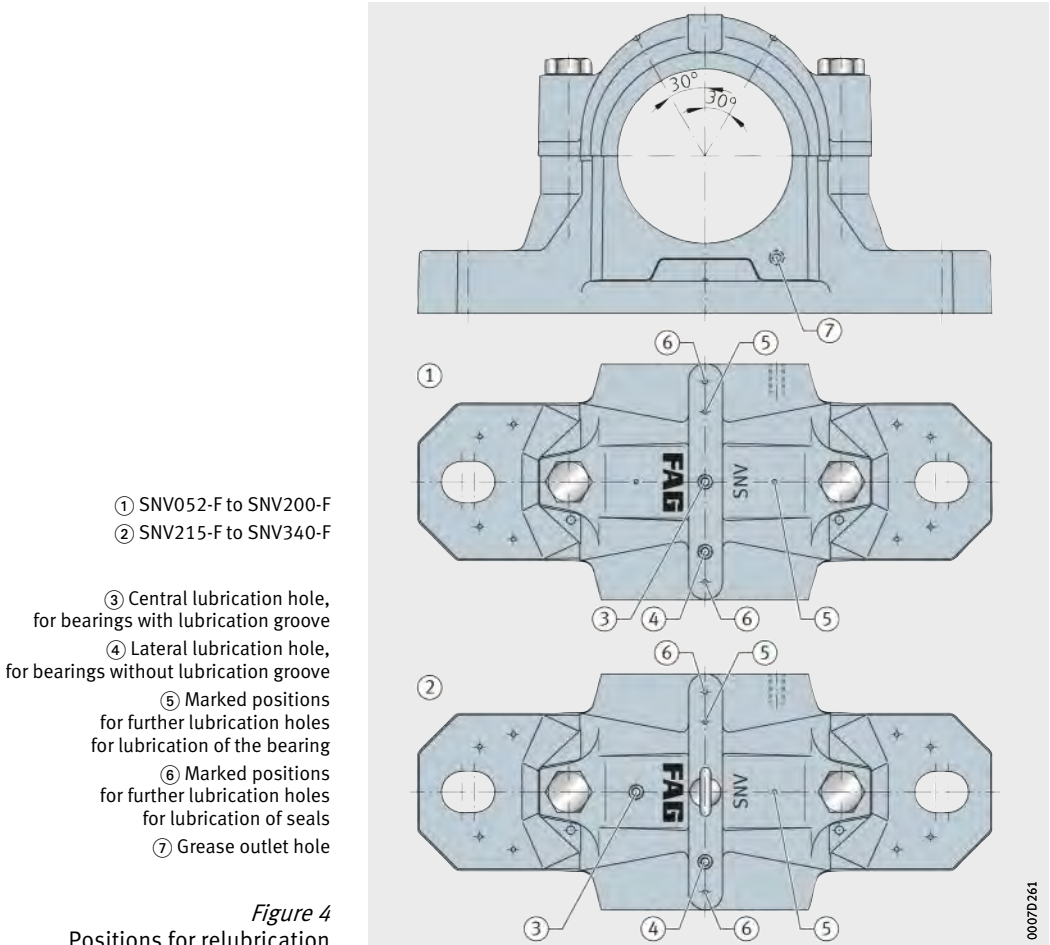



In both cases, the lubrication hole present (threaded hole M10×1) is prepared by removing the screw plug and permanently inserting one of the lubrication nipples supplied at this point. As an alternative to the lubrication holes already present, lubrication holes may be introduced at other positions as indicated by the cast-in pilot holes, *Figure 4*, page 66, ⑤.

Lubrication holes can be introduced at further marked positions for the relubrication of labyrinth seals, *Figure 4*, page 66, ⑥.

For relubrication, minimum quantities of grease are recommended, see table, page 65. In order to prevent overgreasing, the screw plug in the grease outlet hole in the lower housing section must be removed while relubrication is being carried out, *Figure 4*, page 66, ⑦. This allows superfluous grease to escape. This must be observed in particular when using double lip seals DH. Otherwise, there is a risk that the double lip seal will be pressed out of the housing.

The grease outlet hole must then be closed off again using the screw plug.



If unfavourable environmental conditions are present, there is therefore a risk of contaminant ingress into the housing when the grease outlet holes are opened.

Dimensions

The lubrication and grease outlet holes are closed off using screw plugs to DIN 906.

Lubrication nipples with a dust cap are supplied as followed:

- button head lubrication nipples to DIN 3404-M10×1
- taper type lubrication nipples to DIN 71412-AM10×1.

The size of the grease outlet hole is dependent on the size of the housing, see table.

Dimensions of threaded holes

Housing	Thread for	
	grease outlet hole	relubrication hole
SNV052-F – SNV090-F	M10×1	M10×1
SNV100-F – SNV125-F	M14×1,5	
SNV130-F – SNV340-F	M20×1,5	

Split plummer block housings SNV

Oil lubrication

Split plummer block housings SNV are suitable not only for grease lubrication but also for oil bath lubrication and recirculating oil lubrication. The housings have a large internal cavity with oil collector pockets in the lower section. Due to the housing geometry, it is possible to introduce connection holes for oil inlet, oil outlet, an oil sight glass and a temperature sensor.

Dimensions of connection holes for oil lubrication

The recommended dimensions, see tables and *Figure 5*, page 69, are valid for oil bath lubrication and recirculating oil lubrication.

If recirculating oil lubrication is used, the hole M_2 is intended for the oil inlet function. If oil bath lubrication is used, a venting device can be installed for venting of the housing.

If oil bath lubrication is used, the hole M_4 is intended for the oil sight glass. If recirculating oil lubrication is used, the hole can be used for the oil outlet.

Recommended dimensions of connection holes for oil inlet and oil outlet

Housing	Connection for				
	oil inlet		oil outlet		
	M_2	$n_3/2$ mm	M_3	α °	g6 mm
SNV100-F	G1/4	31	M10×1	50	44
SNV110-F	G1/4	33,5	M10×1	50	46
SNV120-F	G1/4	35,5	M10×1	50	49
SNV125-F	G1/4	28,5	M10×1	50	49
SNV130-F	G1/4	38	M10×1	50	51,5
SNV140-F	G1/4	40,5	M10×1	60	57,5
SNV150-F	G1/4	42,5	M10×1	60	60
SNV160-F	G1/4	45	M10×1	60	62,5
SNV170-F	G1/4	46,5	M10×1	60	64
SNV180-F	G1/4	19,5	M10×1	60	69
SNV190-F	G1/4	49,5	M10×1	60	68,5
SNV200-F	G1/4	55,5	M10×1	60	77,5
SNV215-F	G1/4	58,5	M10×1	60	80
SNV230-F	G1/4	61	M10×1	60	83
SNV240-F	G1/4	60	M10×1	60	81,5
SNV250-F	G1/4	65,5	M10×1	60	89
SNV260-F	G1/4	62,5	M10×1	60	84
SNV270-F	G1/4	71,5	M10×1	60	86,5
SNV280-F	G1/4	68	M10×1	60	92,5
SNV290-F	G1/4	76	M10×1	60	102,5
SNV300-F	G1/4	73	M10×1	60	99,5
SNV320-F	G1/4	77	M10×1	60	105,5
SNV340-F	G1/4	81	M10×1	60	109,5

**Recommended dimensions
of connection holes
for oil sight glass**

Housing	Connection for oil sight glass			
	M ₄	g ₇ mm	h ₃	D ₅
SNV100-F	G3/8	33	31	24
SNV110-F	G3/8	35	28	24
SNV120-F	G3/8	38	35	24
SNV125-F	G3/8	44	24	24
SNV130-F	G1/2	43	28,5	30
SNV140-F	G1/2	45	40	30
SNV150-F	G1/2	47	38	30
SNV160-F	G1/2	50	39	30
SNV170-F	G3/4	55	46	36
SNV180-F	G3/4	57	43	36
SNV190-F	G3/4	48	45	36
SNV200-F	G3/4	62	50	36
SNV215-F	G3/4	67	58	36
SNV230-F	G3/4	70	60	36
SNV240-F	G3/4	61	60	36
SNV250-F	G3/4	75	55	36
SNV260-F	G3/4	65	65	36
SNV270-F	G3/4	81	55	36
SNV280-F	G3/4	70	60	36
SNV290-F	G3/4	87	58	36
SNV300-F	G3/4	75	70	36
SNV320-F	G3/4	80	73	36
SNV340-F	G3/4	95	75	36



- ① Venting device
- ② Screw plug
- ③ Oil sight glass

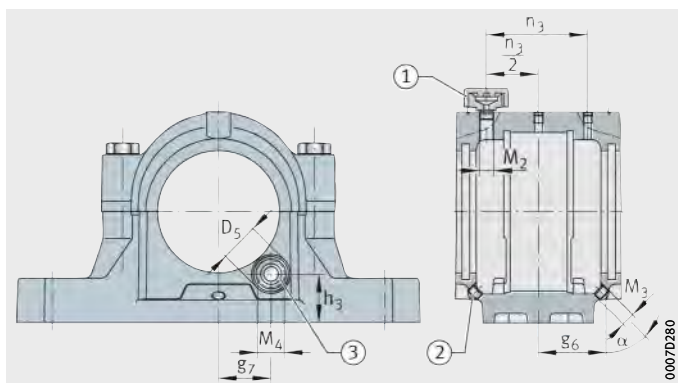

Figure 5
Dimensions of connection holes

Split plummer block housings SNV

Design for oil lubrication

Plummer block housings SNV can be supplied by agreement in a design for oil lubrication. Housings of this design already have the connection holes for oil inlet, oil outlet and an oil sight glass to the recommended dimensions.

The scope of delivery of the design for oil lubrication includes:

- 1 oil sight glass OSGL
- 1 venting device VENT
- 2 screw plugs VSB.

Housings with connection holes according to individual customer specifications can also be supplied once their feasibility has been checked.

Sealing of the shaft

When using the double lip seal DH, a certain amount of oil leakage must be expected, which is unavoidable with seals that are split and not spring-loaded.

In order to limit oil leakage to a small quantity, the shaft in the seal area should have the following characteristics:

- hardness at least 55 HRC
- ground free from spiral marks with a surface roughness of Ra 0,2 µm to Ra 0,5 µm.

A technically oiltight design is only possible with a spring-loaded, unsplit rotary shaft seal.

Sealing of the housing body

The parting line between the upper and lower sections of the housing must be sealed with a thin layer of a commercial sealant (with permanent elasticity). In the case of a housing closed on one side, the base of the groove in which the cover is inserted must be brushed with sealant.

Guidelines on oil bath lubrication

When using oil bath lubrication, a minimum oil level must be ensured. This corresponds to the dimension h3, see table, page 69, and *Figure 5*, page 69.



When using oil bath lubrication, venting of the housing is absolutely necessary. For example, the filling hole can be closed off using a bleed screw.

Designation structure

The designation structure for split plummer block housings SNV and accessories is shown in the tables and *Figure 6* to *Figure 9*, page 73.

Designation structure of plummer block housings SNV

Feature	Code	Description
① Series	SNV	Split plummer block housings SNV
② Bearing outside diameter	340	Outside diameter 340 mm
③ Housing design	F	Threaded holes for grease relubrication and grease outlet
④ Housing material	L	Flake graphite cast iron (standard)
	D	Spheroidal graphite cast iron



Figure 6
Designation structure of plummer block housings SNV, example



Split plummer block housings SNV

Designation structure of standard seals

Feature	Code	Description
① Series	TSV	Labyrinth seal
	TCV	Taconite seal
	DH	Double lip seal
	DHV	V-ring seal
	FSV	Felt seal
② Diameter series of bearing, bearing bore	2	Bearings of diameter series 2, cylindrical bearing bore
	3	Bearings of diameter series 3, cylindrical bearing bore
	5	Bearings of diameter series 2, tapered bearing bore and adapter sleeve
	6	Bearings of diameter series 3, tapered bearing bore and adapter sleeve
③ Bore code of bearing	08	Bore diameter (8 · 5) mm = 40 mm
④ Shaft diameter	No further indications	Standard shaft diameter of dimension series
	X105	Inch size shaft diameter: 1 inch + 5 · 1/16 inch = 15/16 inch



Figure 7
Designation structure of standard seals, examples

Designation structure of covers

Feature	Code	Description
① Series	DKV	Cover made from plastic
	DKVT	Cover made from steel and FKM
② Housing size	080	Cover suitable for housing SNV080

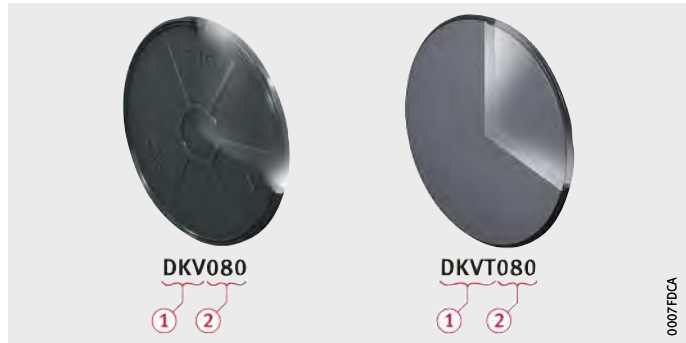

Figure 8
Designation structure of covers, examples

Designation structure of locating rings

Feature	Code	Description
① Series	FRM	Locating ring
② Outside diameter	80	Outside diameter 80 mm
③ Width	10,5	Width 10,5 mm



Figure 9
Designation structure of locating rings, example



Split plumber block housings SNV

Ordering examples

When a split plumber block housing SNV is ordered, the housing designation only describes the housing body. The other components such as seals, covers or locating rings must be ordered separately in the specific design required. The rolling bearing and, if necessary, the adapter sleeve must also be ordered separately.

Plummer block housings SNV with a bearing fitted give non-locating bearing arrangements. These can be converted into locating bearing arrangements through the additional insertion of locating rings FRM.

The ordering examples show the construction of orders for selected housing combinations and the appropriate bearings. The allocation of housings, bearings and accessories for all housing sizes is shown in the dimension tables.

Example 1 Plummer block housing SNV made from flake graphite cast iron, closed on one side, self-aligning ball bearing 2210-K-TVH-C3 as locating bearing, location by means of an adapter sleeve on a shaft diameter of 45 mm, double lip seal.

Order	1	plummer block housing	SNV090-F-L
	1	self-aligning ball bearing	2210-K-TVH-C3
	1	adapter sleeve	H310
	2	locating rings	FRM90/9
	1	cover	DKV090
	1	double lip seal	DH510

Example 2 Plummer block housing SNV made from flake graphite cast iron, for continuous shaft, split spherical roller bearing 222SM70-TVPA as locating bearing, double lip seal.

Order	1	plummer block housing	SNV140-F-L
	1	split spherical roller bearing	222SM70-TVPA
	2	locating rings	FRM140/12,5
	2	double lip seals	DH516

Example 3 Plummer block housing SNV made from spheroidal graphite cast iron, closed on one side, spherical roller bearing 23218-E1-TVPB as non-locating bearing, felt seal.

Order	1	plummer block housing	SNV160-F-D
	1	spherical roller bearing	23218-E1-TVPB
	1	shaft nut	KM18
	1	tab washer	MB18
	1	cover	DKV160
	1	felt seal	FSV218

Design and safety guidelines

Load carrying capacity

Guide values have been determined for the rupture load of plummer block housings SNV and the maximum load carrying capacity of connecting screws for the upper and lower housing sections, *Figure 10* and table, page 76. The guide values are valid for purely static loading.

The guide values for housing rupture load are valid for the standard housing material flake graphite cast iron (suffix L). For spheroidal graphite cast iron (suffix D) a factor of 1,6 should be applied.

The guide values in the table, page 76, are only valid if the flatness of the mounting surface in accordance with DIN EN ISO 1101 corresponds to the tolerance grade IT8 in accordance with DIN EN ISO 286-1 (measured across the diagonal). A precondition for supporting loads is that the housing base surface is completely and rigidly supported.

When determining the permissible static load, safety factors must be applied:

- safety factor of 6 relative to the housing rupture load
- safety factor of 3 relative to the maximum load carrying capacity of the connecting screws.



The housing must not be subjected to an axial load of more than $\frac{2}{3}$ of the housing rupture load F_{180° .

If the housing is subjected to axial load, the permissible axial load of the bearing fitted must be taken into consideration. If the bearing is located on the shaft using an adapter sleeve, the axial retaining force of the bearing and adapter sleeve must also be taken into consideration.

If the load direction is between 55° and 120° or axial load is present, we recommend that the housings should be secured in the load direction by means of stops or dowels.

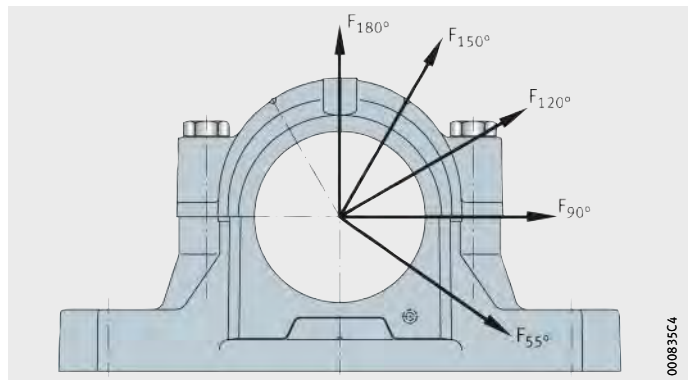

Figure 10
Load directions F
for the guide values
for the housing rupture load and
the maximum load carrying capacity
of the connecting screws



Split plummer block housings SNV

Housing Designation	Housing rupture load in load direction F Housing made from flake graphite cast iron					Connecting screws				
						Thread to DIN 13	Tightening torque ¹⁾ Nm	Maximum load carrying capacity of both screws with contact between parting surfaces in load direction		
	55° kN	90° kN	120° kN	150° kN	180° kN	Material 8.8		120° kN	150° kN	180° kN
SNV052-F-L	160	95	70	60	80	M10	51	60	35	30
SNV062-F-L	170	100	80	65	85	M10	51	60	35	30
SNV072-F-L	190	110	85	80	95	M10	51	60	35	30
SNV080-F-L	210	130	95	85	105	M10	51	60	35	30
SNV085-F-L	225	140	100	90	120	M10	51	60	35	30
SNV090-F-L	265	160	120	105	130	M10	51	60	35	30
SNV100-F-L	280	170	125	120	140	M12	87	80	45	40
SNV110-F-L	300	180	130	125	150	M12	87	80	45	40
SNV120-F-L	335	200	150	130	170	M12	87	80	45	40
SNV125-F-L	335	200	150	130	170	M12	87	80	45	40
SNV130-F-L	400	250	180	150	200	M12	87	80	45	40
SNV140-F-L	425	265	190	170	210	M12	87	80	45	40
SNV150-F-L	475	280	200	180	235	M12	87	80	45	40
SNV160-F-L	530	335	250	210	265	M16	215	180	100	90
SNV170-F-L	560	355	265	225	280	M16	215	180	100	90
SNV180-F-L	630	375	280	250	300	M20	430	260	150	130
SNV190-F-L	630	375	280	250	300	M20	430	260	150	130
SNV200-F-L	670	400	315	280	335	M20	430	260	150	130
SNV215-F-L	800	450	355	315	400	M20	430	260	150	130
SNV230-F-L	900	530	400	355	450	M24	740	360	210	180
SNV240-F-L	1 000	600	450	400	500	M24	740	360	210	180
SNV250-F-L	1 060	630	475	425	530	M24	740	360	210	180
SNV260-F-L	1 180	710	530	475	600	M24	740	360	210	180
SNV270-F-L	1 180	710	530	475	600	M24	740	360	210	180
SNV280-F-L	1 320	750	600	530	630	M24	740	360	210	180
SNV290-F-L	1 400	850	630	560	710	M24	740	360	210	180
SNV300-F-L	1 500	900	670	600	750	M24	740	360	210	180
SNV320-F-L	1 700	1 000	750	670	850	M24	740	360	210	180
SNV340-F-L	1 900	1 120	850	750	950	M30	1 450	640	370	320

Housings made from spheroidal graphite cast iron (suffix D) have a housing rupture load 1,6 times higher than that of housings made from flake graphite cast iron.

¹⁾ The tightening torques are maximum values with 90% utilisation of the yield stress of the screw material and a friction coefficient of 0,14. We recommend tightening the screws to 70% of these values.

Eye bolts

In the case of housings of size SNV215 and larger, the upper housing section has an eye bolt in accordance with DIN 580. This is intended as a locating point for mounting and dismounting of the housing. The load carrying capacity of the eye bolt allows lifting of the housing including a bearing fitted in the housing.



The eye bolt must always be screwed fully into the housing. The eye bolt must not be subjected to a mass greater than that of the housing together with the bearing fitted in the housing.



Foot screws

Foot screws are used for screw mounting of the housing to the mounting surface. They are not included in the scope of delivery of the housings.

The appropriate screw size for each housing is stated, see dimension tables.

The associated tightening torques are stated for screws with a metric thread in accordance with DIN 13, DIN 962 and DIN ISO 965-2, see table, page 42.



Accuracy

The bearing seat in split plummer block housings SNV is machined to the tolerance class G7. The tolerance indicated is valid in the delivered condition, i. e. before the screws connecting the upper and lower sections are loosened.

By agreement, the housings can also be supplied with other tolerance classes for the bearing seat, see section Tolerance class of bearing seat, page 47.

Plummer block housings

SNV, split
For bearings with tapered bore and adapter sleeve
Metric shaft

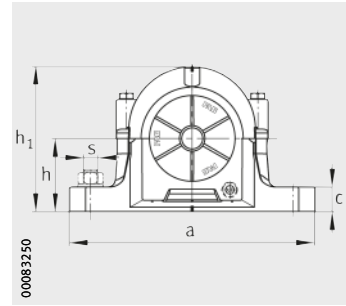
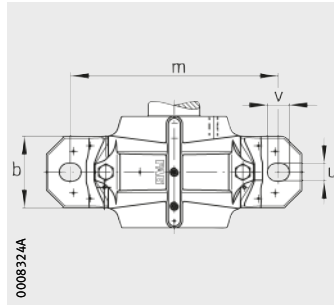

Dimension table - Dimensions in mm

Shaft d_1 mm	Housing Dimensions											Bearing and accessories			
	h	h_1	g	b	c	a	m	v	u	s		D	g_3	Bearing	Adapter sleeve
										mm	inch				
20	40	75	70	46	19	165	130	20	15	M12	1/2	52	10,5	1205-K	H205
20	50	91	75	52	22	185	150	20	15	M12	1/2	62	10,5	1305-K	H305
20	40	75	70	46	19	165	130	20	15	M12	1/2	52	10,5	20205-K	H205
20	40	75	70	46	19	165	130	20	15	M12	1/2	52	10,5	2205-K	H305
20	40	75	70	46	19	165	130	20	15	M12	1/2	52	10,5	22205..-K	H305
20	50	91	75	52	22	185	150	20	15	M12	1/2	62	10,5	2305-K	H2305
25	50	91	75	52	22	185	150	20	15	M12	1/2	62	10,5	1206-K	H206
25	50	97	80	52	22	185	150	20	15	M12	1/2	72	10,5	1306-K	H306
25	50	91	75	52	22	185	150	20	15	M12	1/2	62	10,5	20206-K	H206
25	50	91	75	52	22	185	150	20	15	M12	1/2	62	10,5	2206-K	H306
25	50	91	75	52	22	185	150	20	15	M12	1/2	62	10,5	22206..-K	H306
25	50	97	80	52	22	185	150	20	15	M12	1/2	72	10,5	2306-K	H2306
30	50	97	80	52	22	185	150	20	15	M12	1/2	72	10,5	1207-K	H207
30	60	112	85	60	25	205	170	20	15	M12	1/2	80	10,5	1307-K	H307
30	50	97	80	52	22	185	150	20	15	M12	1/2	72	10,5	20207-K	H207
30	60	112	85	60	25	205	170	20	15	M12	1/2	80	10,5	21307..-K	H307
30	50	97	80	52	22	185	150	20	15	M12	1/2	72	10,5	2207-K	H307
30	50	97	80	52	22	185	150	20	15	M12	1/2	72	10,5	22207..-K	H307
35	60	112	85	60	25	205	170	20	15	M12	1/2	80	10,5	2307-K	H2307
35	60	112	85	60	25	205	170	20	15	M12	1/2	80	10,5	1208-K	H208
35	60	117	100	60	25	205	170	20	15	M12	1/2	90	12,5	1308-K	H308
35	60	112	85	60	25	205	170	20	15	M12	1/2	80	10,5	20208-K	H208
35	60	117	100	60	25	205	170	20	15	M12	1/2	90	12,5	21308..-K	H308
35	60	112	85	60	25	205	170	20	15	M12	1/2	80	10,5	2208-K	H308
35	60	112	85	60	25	205	170	20	15	M12	1/2	80	10,5	22208..-K	H308
35	60	117	100	60	25	205	170	20	15	M12	1/2	90	12,5	22308..-K	H2308
35	60	117	100	60	25	205	170	20	15	M12	1/2	90	12,5	2308-K	H2308

① Locating bearing; ② Non-locating bearing

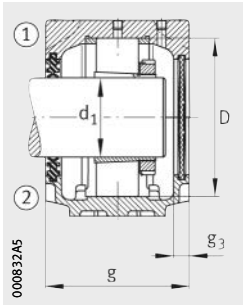

Double lip seal DH
Cover DKV

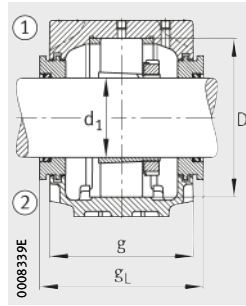

Labyrinth seal TSV

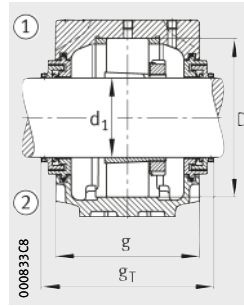

Tacanite seal TCV

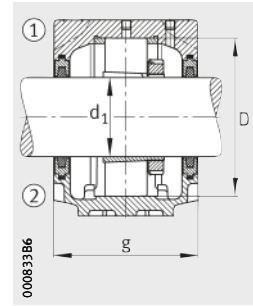

Felt seal FSV



									Housing		
Locating ring	Felt seal	Double lip seal	Labyrinth seal		Tacanite seal		V ring seal		Cover	Mass m ≈ kg	Designation
Quantity 2				gL mm		gT mm		gV mm			
FRM52/6	FSV505	DH505	TSV505	83	–	–	DHV505	76	DKV052	1,3	SNV052-F-L
FRM62/6,5	FSV605	DH605	TSV605	88	–	–	DHV605	81	DKV062	1,9	SNV062-F-L
FRM52/6	FSV505	DH505	TSV505	83	–	–	DHV505	76	DKV052	1,3	SNV052-F-L
FRM52/4,5	FSV505	DH505	TSV505	83	–	–	DHV505	76	DKV052	1,3	SNV052-F-L
FRM52/4,5	FSV505	DH505	TSV505	83	–	–	DHV505	76	DKV052	1,3	SNV052-F-L
FRM62/3	FSV605	DH605	TSV605	88	–	–	DHV605	81	DKV062	1,9	SNV062-F-L
FRM62/7	FSV506	DH506	TSV506	88	–	–	DHV506	81	DKV062	1,9	SNV062-F-L
FRM72/7	FSV606	DH606	TSV606	93	TCV606	117	DHV606	86	DKV072	2	SNV072-F-L
FRM62/7	FSV506	DH506	TSV506	88	–	–	DHV506	81	DKV062	1,9	SNV062-F-L
FRM62/5	FSV506	DH506	TSV506	88	–	–	DHV506	81	DKV062	1,9	SNV062-F-L
FRM62/5	FSV506	DH506	TSV506	88	–	–	DHV506	81	DKV062	1,9	SNV062-F-L
FRM72/3	FSV606	DH606	TSV606	93	TCV606	117	DHV606	86	DKV072	2	SNV072-F-L
FRM72/8	FSV507	DH507	TSV507	93	–	–	DHV507	86	DKV072	2	SNV072-F-L
FRM80/9	FSV607	DH607	TSV607	98	TCV607	122	DHV607	91	DKV080	2,9	SNV080-F-L
FRM72/8	FSV507	DH507	TSV507	93	–	–	DHV507	86	DKV072	2	SNV072-F-L
FRM80/9	FSV607	DH607	TSV607	98	TCV607	122	DHV607	91	DKV080	2,9	SNV080-F-L
FRM72/5	FSV507	DH507	TSV507	93	–	–	DHV507	86	DKV072	2	SNV072-F-L
FRM72/5	FSV507	DH507	TSV507	93	–	–	DHV507	86	DKV072	2	SNV072-F-L
FRM80/4	FSV607	DH607	TSV607	98	TCV607	122	DHV607	91	DKV080	2,9	SNV080-F-L
FRM80/10,5	FSV508	DH508	TSV508	98	TCV508	122	DHV508	91	DKV080	2,9	SNV080-F-L
FRM90/9	FSV608	DH608	TSV608	114	TCV608	136	DHV608	104	DKV090	3,1	SNV090-F-L
FRM80/10,5	FSV508	DH508	TSV508	98	TCV508	122	DHV508	91	DKV080	2,9	SNV080-F-L
FRM90/9	FSV608	DH608	TSV608	114	TCV608	136	DHV608	104	DKV090	3,1	SNV090-F-L
FRM80/8	FSV508	DH508	TSV508	98	TCV508	122	DHV508	91	DKV080	2,9	SNV080-F-L
FRM80/8	FSV508	DH508	TSV508	98	TCV508	122	DHV508	91	DKV080	2,9	SNV080-F-L
FRM90/4	FSV608	DH608	TSV608	114	TCV608	136	DHV608	104	DKV090	3,1	SNV090-F-L
FRM90/4	FSV608	DH608	TSV608	114	TCV608	136	DHV608	104	DKV090	3,1	SNV090-F-L

Plummer block housings

SNV, split
For bearings with tapered bore and adapter sleeve
Metric shaft

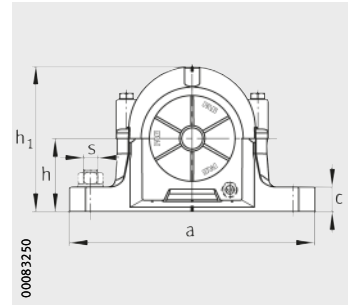
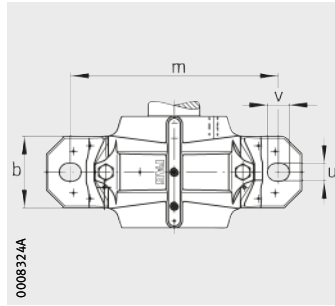

Dimension table (continued) · Dimensions in mm

Shaft d ₁ mm	Housing Dimensions												Bearing and accessories		
	h	h ₁	g	b	c	a	m	v	u	s		D	g ₃	Bearing	Adapter sleeve
									mm	inch					
40	60	114	87	60	25	205	170	20	15	M12	1/2	85	12,5	1209-K	H209
40	70	133	105	70	28	255	210	23	18	M16	5/8	100	12,5	1309-K	H309
40	60	114	87	60	25	205	170	20	15	M12	1/2	85	12,5	20209-K	H209
40	70	133	105	70	28	255	210	23	18	M16	5/8	100	12,5	21309..-K	H309
40	60	114	87	60	25	205	170	20	15	M12	1/2	85	12,5	2209-K	H309
40	60	114	87	60	25	205	170	20	15	M12	1/2	85	12,5	22209..-K	H309
40	70	133	105	70	28	255	210	23	18	M16	5/8	100	12,5	22309..-K	H2309
40	70	133	105	70	28	255	210	23	18	M16	5/8	100	12,5	2309-K	H2309
45	60	117	100	60	25	205	170	20	15	M12	1/2	90	12,5	1210-K	H210
45	70	139	110	70	30	255	210	23	18	M16	5/8	110	12,5	1310-K	H310
45	60	117	100	60	25	205	170	20	15	M12	1/2	90	12,5	20210-K	H210
45	70	139	110	70	30	255	210	23	18	M16	5/8	110	12,5	21310..-K	H310
45	60	117	100	60	25	205	170	20	15	M12	1/2	90	12,5	2210-K	H310
45	60	117	100	60	25	205	170	20	15	M12	1/2	90	12,5	22210..-K	H310
45	70	139	110	70	30	255	210	23	18	M16	5/8	110	12,5	22310..-K	H2310
45	70	139	110	70	30	255	210	23	18	M16	5/8	110	12,5	2310-K	H2310
50	70	133	105	70	28	255	210	23	18	M16	5/8	100	12,5	1211-K	H211
50	80	155	115	80	30	275	230	23	18	M16	5/8	120	12,5	1311-K	H311
50	70	133	105	70	28	255	210	23	18	M16	5/8	100	12,5	20211-K	H211
50	80	155	115	80	30	275	230	23	18	M16	5/8	120	12,5	20311-K	H311
50	80	155	115	80	30	275	230	23	18	M16	5/8	120	12,5	21311..-K	H311
50	70	133	105	70	28	255	210	23	18	M16	5/8	100	12,5	2211-K	H311
50	70	133	105	70	28	255	210	23	18	M16	5/8	100	12,5	22211..-K	H311
50	80	155	115	80	30	275	230	23	18	M16	5/8	120	12,5	22311..-K	H2311
50	80	155	115	80	30	275	230	23	18	M16	5/8	120	12,5	2311-K	H2311
55	70	139	110	70	30	255	210	23	18	M16	5/8	110	12,5	1212-K	H212
55	80	161	120	80	30	280	230	23	18	M16	5/8	130	12,5	1312-K	H312
55	70	139	110	70	30	255	210	23	18	M16	5/8	110	12,5	20212-K	H212
55	80	161	120	80	30	280	230	23	18	M16	5/8	130	12,5	20312-K	H312
55	80	161	120	80	30	280	230	23	18	M16	5/8	130	12,5	21312..-K	H312
55	70	139	110	70	30	255	210	23	18	M16	5/8	110	12,5	2212-K	H312
55	70	139	110	70	30	255	210	23	18	M16	5/8	110	12,5	22212..-K	H312
55	80	161	120	80	30	280	230	23	18	M16	5/8	130	12,5	22312..-K	H2312
55	80	161	120	80	30	280	230	23	18	M16	5/8	130	12,5	2312-K	H2312

① Locating bearing; ② Non-locating bearing

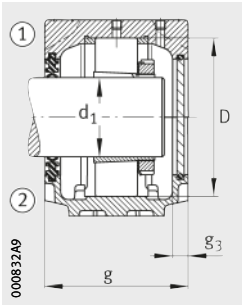

Double lip seal DH
Cover DKVT

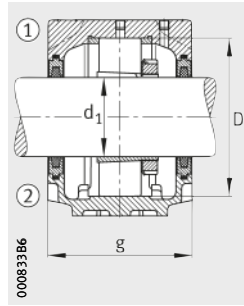

Felt seal FSV

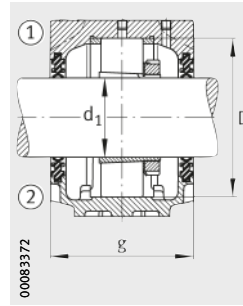

Double lip seal DH

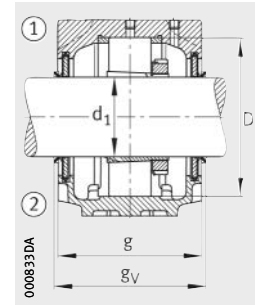

V ring seal DHV



										Housing	
Locating ring	Felt seal	Double lip seal	Labyrinth seal		Taconite seal		V ring seal		Cover	Mass	Designation
Quantity 2				gL mm		gT mm		gv mm		m ≈ kg	
FRM85/6	FSV509	DH509	TSV509	101	TCV509	125	DHV509	93	DKV085	2,8	SNV085-F-L
FRM100/9,5	FSV609	DH609	TSV609	119	TCV609	143	DHV609	111	DKV100	4,3	SNV100-F-L
FRM85/6	FSV509	DH509	TSV509	101	TCV509	125	DHV509	93	DKV085	2,8	SNV085-F-L
FRM100/9,5	FSV609	DH609	TSV609	119	TCV609	143	DHV609	111	DKV100	4,3	SNV100-F-L
FRM85/4	FSV509	DH509	TSV509	101	TCV509	125	DHV509	93	DKV085	2,8	SNV085-F-L
FRM85/4	FSV509	DH509	TSV509	101	TCV509	125	DHV509	93	DKV085	2,8	SNV085-F-L
FRM100/4	FSV609	DH609	TSV609	119	TCV609	143	DHV609	111	DKV100	4,3	SNV100-F-L
FRM100/4	FSV609	DH609	TSV609	119	TCV609	143	DHV609	111	DKV100	4,3	SNV100-F-L
FRM90/10,5	FSV510	DH510	TSV510	114	TCV510	138	DHV510	106	DKV090	3,1	SNV090-F-L
FRM110/10,5	FSV610	DH610	TSV610	124	TCV610	148	DHV610	116	DKV110	4,9	SNV110-F-L
FRM90/10,5	FSV510	DH510	TSV510	114	TCV510	138	DHV510	106	DKV090	3,1	SNV090-F-L
FRM110/10,5	FSV610	DH610	TSV610	124	TCV610	148	DHV610	116	DKV110	4,9	SNV110-F-L
FRM90/9	FSV510	DH510	TSV510	114	TCV510	138	DHV510	106	DKV090	3,1	SNV090-F-L
FRM90/9	FSV510	DH510	TSV510	114	TCV510	138	DHV510	106	DKV090	3,1	SNV090-F-L
FRM110/4	FSV610	DH610	TSV610	124	TCV610	148	DHV610	116	DKV110	4,9	SNV110-F-L
FRM110/4	FSV610	DH610	TSV610	124	TCV610	148	DHV610	116	DKV110	4,9	SNV110-F-L
FRM100/11,5	FSV511	DH511	TSV511	119	TCV511	143	DHV511	111	DKV100	4,3	SNV100-F-L
FRM120/11	FSV611	DH611	TSV611	129	TCV611	153	DHV611	121	DKV120	6,1	SNV120-F-L
FRM100/11,5	FSV511	DH511	TSV511	119	TCV511	143	DHV511	111	DKV100	4,3	SNV100-F-L
FRM120/11	FSV611	DH611	TSV611	129	TCV611	153	DHV611	121	DKV120	6,1	SNV120-F-L
FRM120/11	FSV611	DH611	TSV611	129	TCV611	153	DHV611	121	DKV120	6,1	SNV120-F-L
FRM100/9,5	FSV511	DH511	TSV511	119	TCV511	143	DHV511	111	DKV100	4,3	SNV100-F-L
FRM100/9,5	FSV511	DH511	TSV511	119	TCV511	143	DHV511	111	DKV100	4,3	SNV100-F-L
FRM120/4	FSV611	DH611	TSV611	129	TCV611	153	DHV611	121	DKV120	6,1	SNV120-F-L
FRM120/4	FSV611	DH611	TSV611	129	TCV611	153	DHV611	121	DKV120	6,1	SNV120-F-L
FRM110/13	FSV512	DH512	TSV512	124	TCV512	148	DHV512	116	DKV110	4,9	SNV110-F-L
FRM130/12,5	FSV612	DH612	TSV612	134	TCV612	158	DHV612	126	DKV130	6,8	SNV130-F-L
FRM110/13	FSV512	DH512	TSV512	124	TCV512	148	DHV512	116	DKV110	4,9	SNV110-F-L
FRM130/12,5	FSV612	DH612	TSV612	134	TCV612	158	DHV612	126	DKV130	6,8	SNV130-F-L
FRM130/12,5	FSV612	DH612	TSV612	134	TCV612	158	DHV612	126	DKV130	6,8	SNV130-F-L
FRM110/10	FSV512	DH512	TSV512	124	TCV512	148	DHV512	116	DKV110	4,9	SNV110-F-L
FRM110/10	FSV512	DH512	TSV512	124	TCV512	148	DHV512	116	DKV110	4,9	SNV110-F-L
FRM130/5	FSV612	DH612	TSV612	134	TCV612	158	DHV612	126	DKV130	6,8	SNV130-F-L
FRM130/5	FSV612	DH612	TSV612	134	TCV612	158	DHV612	126	DKV130	6,8	SNV130-F-L

Plummer block housings

SNV, split
For bearings with tapered bore and adapter sleeve
Metric shaft

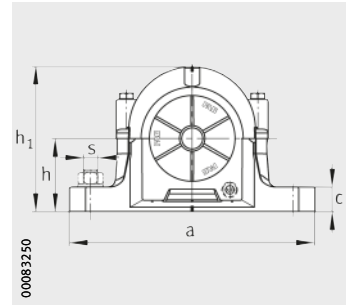
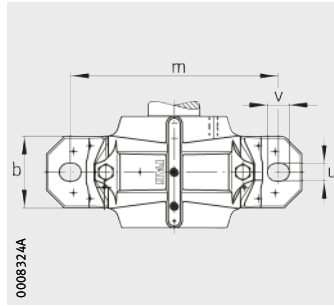

Dimension table (continued) · Dimensions in mm

Shaft d ₁ mm	Housing Dimensions											Bearing and accessories			
	h	h ₁	g	b	c	a	m	v	u	s		D	g ₃	Bearing	Adapter sleeve
										mm	inch				
60	80	155	115	80	30	275	230	23	18	M16	5/8	120	12,5	1213-K	H213
60	95	183	135	90	32	315	260	27	22	M20	3/4	140	15	1313-K	H313
60	80	155	115	80	30	275	230	23	18	M16	5/8	120	12,5	20213-K	H213
60	95	183	135	90	32	315	260	27	22	M20	3/4	140	15	20313-K	H313
60	95	183	135	90	32	315	260	27	22	M20	3/4	140	15	21313..-K	H313
60	80	155	115	80	30	275	230	23	18	M16	5/8	120	12,5	2213-K	H313
60	80	155	115	80	30	275	230	23	18	M16	5/8	120	12,5	22213..-K	H313
60	95	183	135	90	32	315	260	27	22	M20	3/4	140	15	22313..-K	H2313
60	95	183	135	90	32	315	260	27	22	M20	3/4	140	15	2313-K	H2313
65	80	161	120	80	30	280	230	23	18	M16	5/8	130	12,5	1215-K	H215
65	100	201	145	100	35	345	290	27	22	M20	3/4	160	15	1315-K	H315
65	80	161	120	80	30	280	230	23	18	M16	5/8	130	12,5	20215-K	H215
65	100	201	145	100	35	345	290	27	22	M20	3/4	160	15	21315..-K	H315
65	80	161	120	80	30	280	230	23	18	M16	5/8	130	12,5	2215-K	H315
65	80	161	120	80	30	280	230	23	18	M16	5/8	130	12,5	22215..-K	H315
65	100	201	145	100	35	345	290	27	22	M20	3/4	160	15	22315..-K	H2315
65	100	201	145	100	35	345	290	27	22	M20	3/4	160	15	2315-K	H2315
70	95	183	135	90	32	315	260	27	22	M20	3/4	140	15	1216-K	H216
70	112	219	150	100	35	345	290	27	22	M20	3/4	170	16	1316-K	H316
70	95	183	135	90	32	315	260	27	22	M20	3/4	140	15	20216-K	H216
70	112	219	150	100	35	345	290	27	22	M20	3/4	170	16	21316..-K	H316
70	95	183	135	90	32	315	260	27	22	M20	3/4	140	15	2216-K	H316
70	95	183	135	90	32	315	260	27	22	M20	3/4	140	15	22216..-K	H316
70	112	219	150	100	35	345	290	27	22	M20	3/4	170	16	22316..-K	H2316
70	112	219	150	100	35	345	290	27	22	M20	3/4	170	16	2316-K	H2316
75	95	189	140	90	32	320	260	27	22	M20	3/4	150	15	1217-K	H217
75	112	223	160	110	40	380	320	32	26	M24	7/8	180	16	1317-K	H317
75	95	189	140	90	32	320	260	27	22	M20	3/4	150	15	20217-K	H217
75	112	223	160	110	40	380	320	32	26	M24	7/8	180	16	21317..-K	H317
75	95	189	140	90	32	320	260	27	22	M20	3/4	150	15	2217-K	H317
75	95	189	140	90	32	320	260	27	22	M20	3/4	150	15	22217..-K	H317
75	112	223	160	110	40	380	320	32	26	M24	7/8	180	16	22317..-K	H2317
75	112	223	160	110	40	380	320	32	26	M24	7/8	180	16	2317-K	H2317

① Locating bearing; ② Non-locating bearing

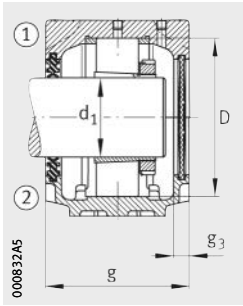

Double lip seal DH
Cover DKV

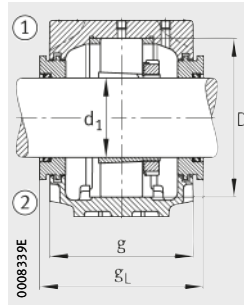

Labyrinth seal TSV

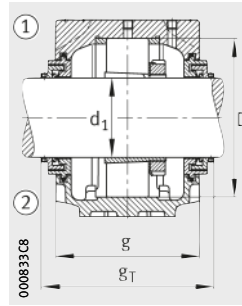

Taconite seal TCV

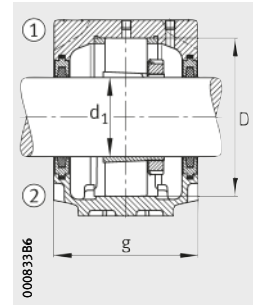

Felt seal FSV



										Housing	
Locating ring	Felt seal	Double lip seal	Labyrinth seal		Taconite seal		V ring seal		Cover	Mass m ≈ kg	Designation
Quantity 2				gL mm		gT mm		gV mm			
FRM120/14	FSV513	DH513	TSV513	129	TCV513	153	DHV513	121	DKV120	6,1	SNV120-F-L
FRM140/12,5	FSV613	DH613	TSV613	150,3	TCV613	172	DHV613	139	DKV140	9,3	SNV140-F-L
FRM120/14	FSV513	DH513	TSV513	129	TCV513	153	DHV513	121	DKV120	6,1	SNV120-F-L
FRM140/12,5	FSV613	DH613	TSV613	150,3	TCV613	172	DHV613	139	DKV140	9,3	SNV140-F-L
FRM140/12,5	FSV613	DH613	TSV613	150,3	TCV613	172	DHV613	139	DKV140	9,3	SNV140-F-L
FRM120/10	FSV513	DH513	TSV513	129	TCV513	153	DHV513	121	DKV120	6,1	SNV120-F-L
FRM120/10	FSV513	DH513	TSV513	129	TCV513	153	DHV513	121	DKV120	6,1	SNV120-F-L
FRM140/5	FSV613	DH613	TSV613	150,3	TCV613	172	DHV613	139	DKV140	9,3	SNV140-F-L
FRM140/5	FSV613	DH613	TSV613	150,3	TCV613	172	DHV613	139	DKV140	9,3	SNV140-F-L
FRM130/15,5	FSV515	DH515	TSV515	134	TCV515	158	DHV515	126	DKV130	6,8	SNV130-F-L
FRM160/14	FSV615	DH615	TSV615	160,3	TCV615	182	DHV615	149	DKV160	12,8	SNV160-F-L
FRM130/15,5	FSV515	DH515	TSV515	134	TCV515	158	DHV515	126	DKV130	6,8	SNV130-F-L
FRM160/14	FSV615	DH615	TSV615	160,3	TCV615	182	DHV615	149	DKV160	12,8	SNV160-F-L
FRM130/12,5	FSV515	DH515	TSV515	134	TCV515	158	DHV515	126	DKV130	6,8	SNV130-F-L
FRM130/12,5	FSV515	DH515	TSV515	134	TCV515	158	DHV515	126	DKV130	6,8	SNV130-F-L
FRM160/5	FSV615	DH615	TSV615	160,3	TCV615	182	DHV615	149	DKV160	12,8	SNV160-F-L
FRM160/5	FSV615	DH615	TSV615	160,3	TCV615	182	DHV615	149	DKV160	12,8	SNV160-F-L
FRM140/16	FSV516	DH516	TSV516	150,3	TCV516	176	DHV516	143	DKV140	9,3	SNV140-F-L
FRM170/14,5	FSV616	DH616	TSV616	167,3	TCV616	193	DHV616	158	DKV170	14,4	SNV170-F-L
FRM140/16	FSV516	DH516	TSV516	150,3	TCV516	176	DHV516	143	DKV140	9,3	SNV140-F-L
FRM170/14,5	FSV616	DH616	TSV616	167,3	TCV616	193	DHV616	158	DKV170	14,4	SNV170-F-L
FRM140/12,5	FSV516	DH516	TSV516	150,3	TCV516	176	DHV516	143	DKV140	9,3	SNV140-F-L
FRM140/12,5	FSV516	DH516	TSV516	150,3	TCV516	176	DHV516	143	DKV140	9,3	SNV140-F-L
FRM170/5	FSV616	DH616	TSV616	167,3	TCV616	193	DHV616	158	DKV170	14,4	SNV170-F-L
FRM170/5	FSV616	DH616	TSV616	167,3	TCV616	193	DHV616	158	DKV170	14,4	SNV170-F-L
FRM150/16,5	FSV517	DH517	TSV517	155,3	TCV517	181	DHV517	148	DKV150	9,9	SNV150-F-L
FRM180/14,5	FSV617	DH617	TSV617	177,3	TCV617	203	DHV617	168	DKV180	17	SNV180-F-L
FRM150/16,5	FSV517	DH517	TSV517	155,3	TCV517	181	DHV517	148	DKV150	9,9	SNV150-F-L
FRM180/14,5	FSV617	DH617	TSV617	177,3	TCV617	203	DHV617	168	DKV180	17	SNV180-F-L
FRM150/12,5	FSV517	DH517	TSV517	155,3	TCV517	181	DHV517	148	DKV150	9,9	SNV150-F-L
FRM150/12,5	FSV517	DH517	TSV517	155,3	TCV517	181	DHV517	148	DKV150	9,9	SNV150-F-L
FRM180/5	FSV617	DH617	TSV617	177,3	TCV617	203	DHV617	168	DKV180	17	SNV180-F-L
FRM180/5	FSV617	DH617	TSV617	177,3	TCV617	203	DHV617	168	DKV180	17	SNV180-F-L

Plummer block housings

SNV, split
 For bearings with tapered bore and adapter sleeve
 Metric shaft

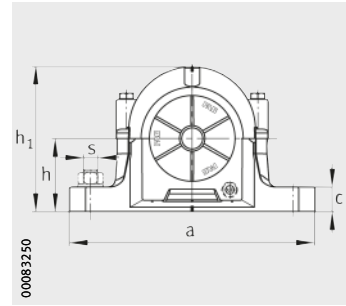
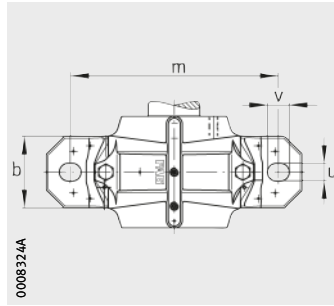

Dimension table (continued) · Dimensions in mm

Shaft d ₁ mm	Housing Dimensions													Bearing and accessories	
	h	h ₁	g	b	c	a	m	v	u	s		D	g ₃	Bearing	Adapter sleeve
										mm	inch				
80	100	201	145	100	35	345	290	27	22	M20	3/4	160	15	1218-K	H218
80	112	229	155	110	40	380	320	32	26	M24	7/8	190	15	1318-K	H318
80	100	201	145	100	35	345	290	27	22	M20	3/4	160	15	20218-K	H218
80	112	229	155	110	40	380	320	32	26	M24	7/8	190	15	20318-K	H318
80	112	229	155	110	40	380	320	32	26	M24	7/8	190	15	21318.-K	H318
80	100	201	145	100	35	345	290	27	22	M20	3/4	160	15	2218-K	H318
80	100	201	145	100	35	345	290	27	22	M20	3/4	160	15	22218.-K	H318
80	112	229	155	110	40	380	320	32	26	M24	7/8	190	15	22318.-K	H2318
80	112	229	155	110	40	380	320	32	26	M24	7/8	190	15	2318-K	H2318
80	100	201	145	100	35	345	290	27	22	M20	3/4	160	15	23218.-K	H2318
85	112	219	150	100	35	345	290	27	22	M20	3/4	170	16	1219-K	H219
85	125	248	175	120	45	410	350	32	26	M24	7/8	200	16	1319-K	H319
85	125	248	175	120	45	410	350	32	26	M24	7/8	200	16	21319.-K	H319
85	112	219	150	100	35	345	290	27	22	M20	3/4	170	16	2219-K	H319
85	112	219	150	100	35	345	290	27	22	M20	3/4	170	16	22219.-K	H319
85	125	248	175	120	45	410	350	32	26	M24	7/8	200	16	22319.-K	H2319
85	125	248	175	120	45	410	350	32	26	M24	7/8	200	16	2319-K	H2319
90	112	223	160	110	40	380	320	32	26	M24	7/8	180	16	1220-K	H220
90	140	271	180	120	45	410	350	32	26	M24	7/8	215	16	1320-K	H320
90	112	223	160	110	40	380	320	32	26	M24	7/8	180	16	20220-K	H220
90	140	271	180	120	45	410	350	32	26	M24	7/8	215	16	20320-K	H320
90	140	271	180	120	45	410	350	32	26	M24	7/8	215	16	21320.-K	H320
90	112	223	160	110	40	380	320	32	26	M24	7/8	180	16	2220-K	H320
90	112	223	160	110	40	380	320	32	26	M24	7/8	180	16	22220.-K	H320
90	140	271	180	120	45	410	350	32	26	M24	7/8	215	16	22320.-K	H2320
90	140	271	180	120	45	410	350	32	26	M24	7/8	215	16	2320-K	H2320
90	112	223	160	110	40	380	320	32	26	M24	7/8	180	16	23220.-K	H2320

① Locating bearing; ② Non-locating bearing

1) Housing with eye bolt.

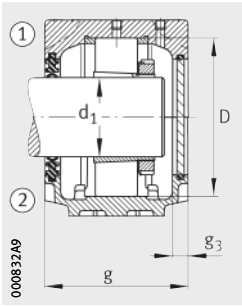

Double lip seal DH
Cover DKVT

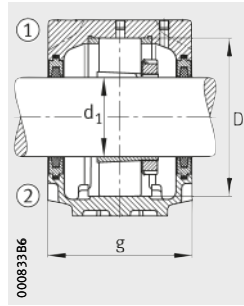

Felt seal FSV

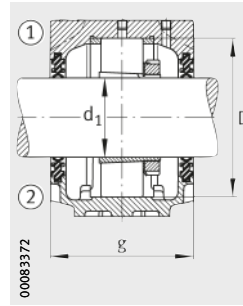

Double lip seal DH

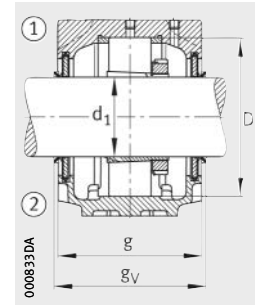

V ring seal DHV



										Housing	
Locating ring	Felt seal	Double lip seal	Labyrinth seal		Taconite seal		V ring seal		Cover	Mass m ≈ kg	Designation
Quantity 2				gL mm		gT mm		gv mm			
FRM160/17,5	FSV518	DH518	TSV518	160,3	TCV518	186	DHV518	153	DKV160	12,8	SNV160-F-L
FRM190/15,5	FSV518	DH518	TSV518	170,3	TCV518	178	DHV518	163	DKV160	22	SNV190-F-L
FRM160/17,5	FSV518	DH518	TSV518	160,3	TCV518	186	DHV518	153	DKV160	12,8	SNV160-F-L
FRM190/15,5	FSV518	DH518	TSV518	170,3	TCV518	178	DHV518	163	DKV160	22	SNV190-F-L
FRM190/15,5	FSV518	DH518	TSV518	170,3	TCV518	178	DHV518	163	DKV160	22	SNV190-F-L
FRM160/12,5	FSV518	DH518	TSV518	160,3	TCV518	186	DHV518	153	DKV160	12,8	SNV160-F-L
FRM160/12,5	FSV518	DH518	TSV518	160,3	TCV518	186	DHV518	153	DKV160	12,8	SNV160-F-L
FRM190/5	FSV518	DH518	TSV518	170,3	TCV518	178	DHV518	163	DKV160	22	SNV190-F-L
FRM190/5	FSV518	DH518	TSV518	170,3	TCV518	178	DHV518	163	DKV160	22	SNV190-F-L
FRM160/6,3	FSV518	DH518	TSV518	160,3	TCV518	186	DHV518	153	DKV160	12,8	SNV160-F-L
FRM170/18	FSV519	DH519	TSV519	167,3	TCV519	193	DHV519	158	DKV170	14,4	SNV170-F-L
FRM200/17,5	FSV619	DH619	TSV619	192,3	TCV619	218	DHV619	183	DKV200	21	SNV200-F-L
FRM200/17,5	FSV619	DH619	TSV619	192,3	TCV619	218	DHV619	183	DKV200	21	SNV200-F-L
FRM170/12,5	FSV519	DH519	TSV519	167,3	TCV519	193	DHV519	158	DKV170	14,4	SNV170-F-L
FRM170/12,5	FSV519	DH519	TSV519	167,3	TCV519	193	DHV519	158	DKV170	14,4	SNV170-F-L
FRM200/6,5	FSV619	DH619	TSV619	192,3	TCV619	218	DHV619	183	DKV200	21	SNV200-F-L
FRM200/6,5	FSV619	DH619	TSV619	192,3	TCV619	218	DHV619	183	DKV200	21	SNV200-F-L
FRM180/18	FSV520	DH520	TSV520	177,3	TCV520	203	DHV520	168	DKV180	17	SNV180-F-L
FRM215/19,5	FSV620	DH620	TSV620	197,3	TCV620	224	DHV620	188	DKV215	24,5	SNV215-F-L¹⁾
FRM180/18	FSV520	DH520	TSV520	177,3	TCV520	203	DHV520	168	DKV180	17	SNV180-F-L
FRM215/19,5	FSV620	DH620	TSV620	197,3	TCV620	224	DHV620	188	DKV215	24,5	SNV215-F-L¹⁾
FRM215/19,5	FSV620	DH620	TSV620	197,3	TCV620	224	DHV620	188	DKV215	24,5	SNV215-F-L¹⁾
FRM180/12	FSV520	DH520	TSV520	177,3	TCV520	203	DHV520	168	DKV180	17	SNV180-F-L
FRM180/12	FSV520	DH520	TSV520	177,3	TCV520	203	DHV520	168	DKV180	17	SNV180-F-L
FRM215/6,5	FSV620	DH620	TSV620	197,3	TCV620	224	DHV620	188	DKV215	24,5	SNV215-F-L¹⁾
FRM215/6,5	FSV620	DH620	TSV620	197,3	TCV620	224	DHV620	188	DKV215	24,5	SNV215-F-L¹⁾
FRM180/4,85	FSV520	DH520	TSV520	177,3	TCV520	203	DHV520	168	DKV180	17	SNV180-F-L

Plummer block housings

SNV, split
For bearings with tapered bore and adapter sleeve
Metric shaft

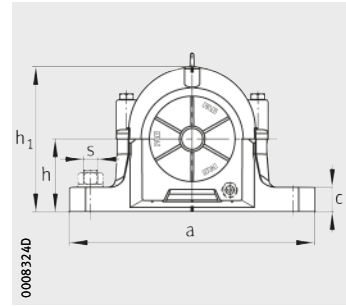
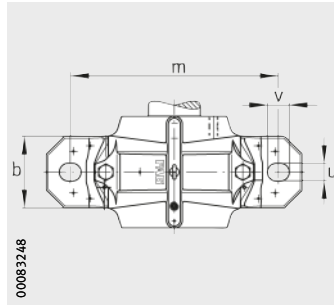

Dimension table (continued) · Dimensions in mm

Shaft d ₁ mm	Housing Dimensions											Bearing and accessories			
	h	h ₁	g	b	c	a	m	v	u	s		D	g ₃	Bearing	Adapter sleeve
										mm	inch				
100	125	248	175	120	45	410	350	32	26	M24	7/8	200	16	1222-K	H222
100	150	298	185	130	50	450	390	35	28	M24	1	240	18	1322-K	H322
100	125	248	175	120	45	410	350	32	26	M24	7/8	200	16	20222-K	H222
100	150	298	185	130	50	450	390	35	28	M24	1	240	18	21322..-K	H322
100	125	248	175	120	45	410	350	32	26	M24	7/8	200	16	22222..-K	H322
100	125	248	175	120	45	410	350	32	26	M24	7/8	200	16	2222-K	H322
100	150	298	185	130	50	450	390	35	28	M24	1	240	18	22322..-K	H2322
100	125	248	175	120	45	410	350	32	26	M24	7/8	200	16	23222..-K	H2322
100	150	298	185	130	50	450	390	35	28	M24	1	240	18	2322-K	H2322
110	140	271	180	120	45	410	350	32	26	M24	7/8	215	16	20224-K	H3024
110	140	271	180	120	45	410	350	32	26	M24	7/8	215	16	22224..-K	H3124
110	160	321	190	160	60	530	450	42	35	M30	1 1/4	260	18	22324..-K	H2324
110	140	271	180	120	45	410	350	32	26	M24	7/8	215	16	23224..-K	H2324
115	150	291	190	130	50	445	380	35	28	M24	1	230	18	20226-K	H3026
115	150	291	190	130	50	445	380	35	28	M24	1	230	18	22226..-K	H3126
115	170	344	205	160	60	550	470	42	35	M30	1 1/4	280	18	22326..-K	H2326
115	150	291	190	130	50	445	380	35	28	M24	1	230	18	23226..-K	H2326
125	150	304	200	150	50	500	420	42	35	M30	1 1/4	250	18	20228-K	H3028
125	150	304	200	150	50	500	420	42	35	M30	1 1/4	250	18	22228..-K	H3128
125	180	366	215	170	65	620	520	42	35	M30	1 1/4	300	18	22328..-K	H2328
125	150	304	200	150	50	500	420	42	35	M30	1 1/4	250	18	23228..-K	H2328
135	160	328	215	160	60	530	450	42	35	M30	1 1/4	270	18	20230-K	H3030
135	160	328	215	160	60	530	450	42	35	M30	1 1/4	270	18	22230..-K	H3130
135	190	386	225	180	65	650	560	42	35	M30	1 1/4	320	18	22330..-K	H2330
135	160	328	215	160	60	530	450	42	35	M30	1 1/4	270	18	23230..-K	H2330
140	170	351	225	160	60	550	470	42	35	M30	1 1/4	290	18	20232-K	H3032(-HG)
140	170	351	225	160	60	550	470	42	35	M30	1 1/4	290	18	22232..-K	H3132(-HG)
140	200	406	235	190	70	680	580	50	42	M36	1 1/2	340	18	22332-K	H2332(-HG)
140	170	351	225	160	60	550	470	42	35	M30	1 1/4	290	18	23232..-K	H2332(-HG)

① Locating bearing; ② Non-locating bearing

¹⁾ Housing without eye bolt.

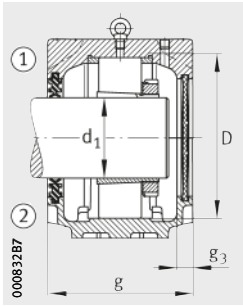

Double lip seal DH
Cover DKV

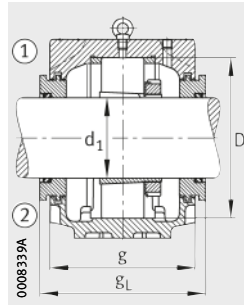

Labyrinth seal TSV

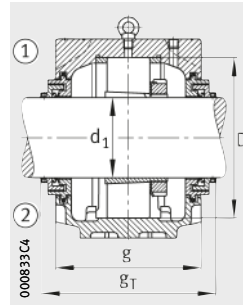

Taconite seal TCV

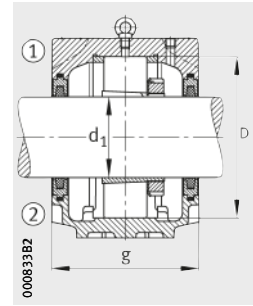

Felt seal FSV



										Housing	
Locating ring	Felt seal	Double lip seal	Labyrinth seal		Taconite seal		V ring seal		Cover	Mass m ≈ kg	Designation
Quantity 2				g _L mm		g _T mm		g _v mm			
FRM200/21	FSV522	DH522	TSV522	195,3	TCV522	218	DHV522	183	DKV200	21	SNV200-F-L¹
FRM240/20	FSV522	DH522	TSV522	203,3	TCV522	226	DHV522	191	DKV200	32	SNV240-F-L
FRM200/21	FSV522	DH522	TSV522	195,3	TCV522	218	DHV522	183	DKV200	21	SNV200-F-L¹
FRM240/20	FSV522	DH522	TSV522	203,3	TCV522	226	DHV522	191	DKV200	32	SNV240-F-L
FRM200/13,5	FSV522	DH522	TSV522	195,3	TCV522	218	DHV522	183	DKV200	21	SNV200-F-L¹
FRM200/13,5	FSV522	DH522	TSV522	195,3	TCV522	218	DHV522	183	DKV200	21	SNV200-F-L¹
FRM240/5	FSV522	DH522	TSV522	203,3	TCV522	226	DHV522	191	DKV200	32	SNV240-F-L
FRM200/5,1	FSV522	DH522	TSV522	195,3	TCV522	218	DHV522	183	DKV200	21	SNV200-F-L¹
FRM240/5	FSV522	DH522	TSV522	203,3	TCV522	226	DHV522	191	DKV200	32	SNV240-F-L
FRM215/23	FSV524	DH524	TSV524	200,3	TCV524	227	DHV524	191	DKV215	24,5	SNV215-F-L
FRM215/14	FSV524	DH524	TSV524	200,3	TCV524	227	DHV524	191	DKV215	24,5	SNV215-F-L
FRM260/5	FSV524	DH524	TSV524	208,3	TCV524	235	DHV524	199	DKV215	48	SNV260-F-L
FRM215/5	FSV524	DH524	TSV524	200,3	TCV524	227	DHV524	191	DKV215	24,5	SNV215-F-L
FRM230/25	FSV526	DH526	TSV526	208,3	TCV526	235	DHV526	199	DKV230	30	SNV230-F-L
FRM230/13	FSV526	DH526	TSV526	208,3	TCV526	235	DHV526	199	DKV230	30	SNV230-F-L
FRM280/5	FSV526	DH526	TSV526	223,3	TCV526	250	DHV526	214	DKV230	55	SNV280-F-L
FRM230/5	FSV526	DH526	TSV526	208,3	TCV526	235	DHV526	199	DKV230	30	SNV230-F-L
FRM250/28	FSV528	DH528	TSV528	218,3	TCV528	245	DHV528	209	DKV250	38	SNV250-F-L
FRM250/15	FSV528	DH528	TSV528	218,3	TCV528	245	DHV528	209	DKV250	38	SNV250-F-L
FRM300/5	FSV528	DH528	TSV528	233,3	TCV528	260	DHV528	224	DKV250	70	SNV300-F-L
FRM250/5	FSV528	DH528	TSV528	218,3	TCV528	245	DHV528	209	DKV250	38	SNV250-F-L
FRM270/30,5	FSV530	DH530	TSV530	233,3	TCV530	260	DHV530	224	DKV270	45,5	SNV270-F-L
FRM270/16,5	FSV530	DH530	TSV530	233,3	TCV530	260	DHV530	224	DKV270	45,5	SNV270-F-L
FRM320/5	FSV530	DH530	TSV530	243,3	TCV530	270	DHV530	234	DKV270	95	SNV320-F-L
FRM270/5	FSV530	DH530	TSV530	233,3	TCV530	260	DHV530	224	DKV270	45,5	SNV270-F-L
FRM290/33	FSV532	DH532	TSV532	243,3	TCV532	270	DHV532	234	DKV290	53,8	SNV290-F-L
FRM290/17	FSV532	DH532	TSV532	243,3	TCV532	270	DHV532	234	DKV290	53,8	SNV290-F-L
FRM340/5	FSV532	DH532	TSV532	253,3	TCV532	298	DHV532	244	DKV290	115	SNV340-F-L
FRM290/5	FSV532	DH532	TSV532	243,3	TCV532	270	DHV532	234	DKV290	53,8	SNV290-F-L

Plummer block housings

SNV, split
For bearings
with cylindrical bore
Metric shaft

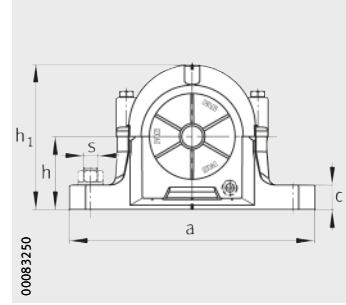
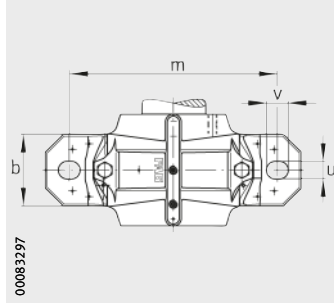

Dimension table - Dimensions in mm

Shaft		Housing Dimensions											Bearing and accessories				
d	d ₂	h	h ₁	g	b	c	a	m	v	u	s		D	g ₃	Bearing	Lock-nut	Tab washer
											mm	inch					
20	25	40	75	70	46	19	165	130	20	15	M12	1/2	52	10,5	1304	KM4	MB4
20	25	40	75	70	46	19	165	130	20	15	M12	1/2	52	10,5	2304	KM4	MB4
20	25	40	75	70	46	19	165	130	20	15	M12	1/2	52	10,5	20304	KM4	MB4
20	25	40	75	70	46	19	165	130	20	15	M12	1/2	52	10,5	21304	KM4	MB4
25	30	40	75	70	46	19	165	130	20	15	M12	1/2	52	10,5	1205	KM5	MB5
25	30	50	91	75	52	22	185	150	20	15	M12	1/2	62	10,5	1305	KM5	MB5
25	30	40	75	70	46	19	165	130	20	15	M12	1/2	52	10,5	2205	KM5	MB5
25	30	50	91	75	52	22	185	150	20	15	M12	1/2	62	10,5	2305	KM5	MB5
25	30	40	75	70	46	19	165	130	20	15	M12	1/2	52	10,5	20205	KM5	MB5
25	30	50	91	75	52	22	185	150	20	15	M12	1/2	62	10,5	20305	KM5	MB5
25	30	50	91	75	52	22	185	150	20	15	M12	1/2	62	10,5	21305	KM5	MB5
25	30	40	75	70	46	19	165	130	20	15	M12	1/2	52	10,5	22205	KM5	MB5
30	35	50	91	75	52	22	185	150	20	15	M12	1/2	62	10,5	1206	KM6	MB6
30	35	50	97	80	52	22	185	150	20	15	M12	1/2	72	10,5	1306	KM6	MB6
30	35	50	91	75	52	22	185	150	20	15	M12	1/2	62	10,5	2206	KM6	MB6
30	35	50	97	80	52	22	185	150	20	15	M12	1/2	72	10,5	2306	KM6	MB6
30	35	50	91	75	52	22	185	150	20	15	M12	1/2	62	10,5	20206	KM6	MB6
30	35	50	97	80	52	22	185	150	20	15	M12	1/2	72	10,5	20306	KM6	MB6
30	35	50	97	80	52	22	185	150	20	15	M12	1/2	72	10,5	21306	KM6	MB6
30	35	50	91	75	52	22	185	150	20	15	M12	1/2	62	10,5	22206	KM6	MB6
35	45	50	97	80	52	22	185	150	20	15	M12	1/2	72	10,5	1207	KM7	MB7
35	45	60	112	85	60	25	205	170	20	15	M12	1/2	80	10,5	1307	KM7	MB7
35	45	50	97	80	52	22	185	150	20	15	M12	1/2	72	10,5	2207	KM7	MB7
35	45	60	112	85	60	25	205	170	20	15	M12	1/2	80	10,5	2307	KM7	MB7
35	45	50	97	80	52	22	185	150	20	15	M12	1/2	72	10,5	20207	KM7	MB7
35	45	60	112	85	60	25	205	170	20	15	M12	1/2	80	10,5	20307	KM7	MB7
35	45	60	112	85	60	25	205	170	20	15	M12	1/2	80	10,5	21307	KM7	MB7
35	45	50	97	80	52	22	185	150	20	15	M12	1/2	72	10,5	22207	KM7	MB7

① Locating bearing; ② Non-locating bearing

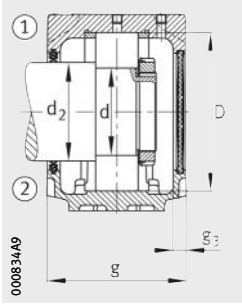

Double lip seal DH
Cover DKV

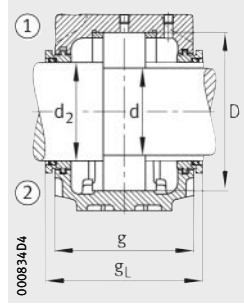

Labyrinth seal TSV

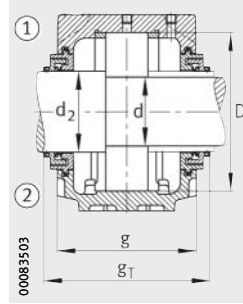

Taconite seal TCv

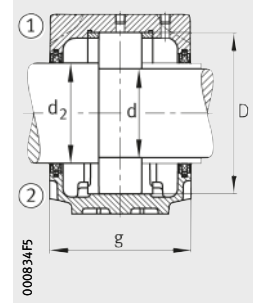

Felt seal FSV



										Housing	
Locating ring	Felt seal	Double lip seal	Labyrinth seal		V ring seal		Taconite seal		Cover	Mass m ≈ kg	Designation
				g _L mm		g _v mm		g _T mm			
Quantity 2											
FRM52/6	–	DH304	TSV304	95	DHV304	76	–	–	DKV052	1,3	SNV052-F-L
FRM52/3	–	DH304	TSV304	95	DHV304	76	–	–	DKV052	1,3	SNV052-F-L
FRM52/6	–	DH304	TSV304	95	DHV304	76	–	–	DKV052	1,3	SNV052-F-L
FRM52/6	–	DH304	TSV304	95	DHV304	76	–	–	DKV052	1,3	SNV052-F-L
FRM52/6	–	DH205	TSV205	95	–	–	–	–	DKV052	1,3	SNV052-F-L
FRM62/6,5	FSV305	DH305	TSV305	100	DHV305	81	–	–	DKV062	1,9	SNV062-F-L
FRM52/4,5	–	DH205	TSV205	95	–	–	–	–	DKV052	1,3	SNV052-F-L
FRM62/3	FSV305	DH305	TSV305	100	DHV305	81	–	–	DKV062	1,9	SNV062-F-L
FRM52/6	–	DH205	TSV205	95	–	–	–	–	DKV052	1,3	SNV052-F-L
FRM62/6,5	FSV305	DH305	TSV305	100	DHV305	81	–	–	DKV062	1,9	SNV062-F-L
FRM62/6,5	FSV305	DH305	TSV305	100	DHV305	81	–	–	DKV062	1,9	SNV062-F-L
FRM52/4,5	–	DH205	TSV205	95	–	–	–	–	DKV052	1,3	SNV052-F-L
FRM62/7	–	DH206	TSV206	100	–	–	–	–	DKV062	1,9	SNV062-F-L
FRM72/7	FSV306	DH306	TSV306	93	DHV306	86	–	–	DKV072	2	SNV072-F-L
FRM62/5	–	DH206	TSV206	100	–	–	–	–	DKV062	1,9	SNV062-F-L
FRM72/3	FSV306	DH306	TSV306	93	DHV306	86	–	–	DKV072	2	SNV072-F-L
FRM62/7	–	DH206	TSV206	100	–	–	–	–	DKV062	1,9	SNV062-F-L
FRM72/7	FSV306	DH306	TSV306	93	DHV306	86	–	–	DKV072	2	SNV072-F-L
FRM72/7	FSV306	DH306	TSV306	93	DHV306	86	–	–	DKV072	2	SNV072-F-L
FRM62/5	–	DH206	TSV206	100	–	–	–	–	DKV062	1,9	SNV062-F-L
FRM72/8	–	DH207	TSV207	107	–	–	–	–	DKV072	2	SNV072-F-L
FRM80/9	FSV307	DH307	TSV307	98	DHV307	93	–	–	DKV080	2,9	SNV080-F-L
FRM72/5	–	DH207	TSV207	107	–	–	–	–	DKV072	2	SNV072-F-L
FRM80/4	FSV307	DH307	TSV307	98	DHV307	93	–	–	DKV080	2,9	SNV080-F-L
FRM72/8	–	DH207	TSV207	107	–	–	–	–	DKV072	2	SNV072-F-L
FRM80/9	FSV307	DH307	TSV307	98	DHV307	93	–	–	DKV080	2,9	SNV080-F-L
FRM80/9	FSV307	DH307	TSV307	98	DHV307	93	–	–	DKV080	2,9	SNV080-F-L
FRM72/5	–	DH207	TSV207	107	–	–	–	–	DKV072	2	SNV072-F-L

Plummer block housings

SNV, split
For bearings with cylindrical bore
Metric shaft

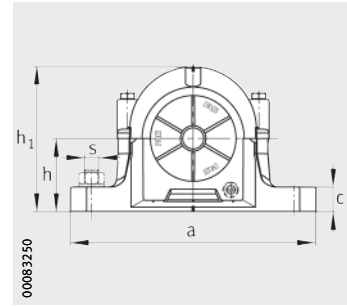
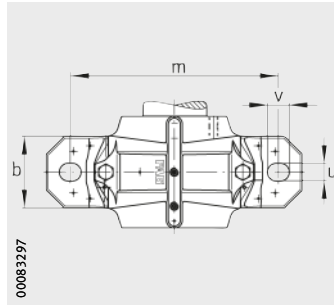

Dimension table (continued) · Dimensions in mm

Shaft		Housing Dimensions										Bearing and accessories					
d	d ₂	h	h ₁	g	b	c	a	m	v	u	s		D	g ₃	Bearing	Lock-nut	Tab washer
											mm	inch					
40	50	60	112	85	60	25	205	170	20	15	M12	1/2	80	10,5	1208	KM8	MB8
40	50	60	117	100	60	25	205	170	20	15	M12	1/2	90	12,5	1308	KM8	MB8
40	50	60	112	85	60	25	205	170	20	15	M12	1/2	80	10,5	2208	KM8	MB8
40	50	60	117	100	60	25	205	170	20	15	M12	1/2	90	12,5	2308	KM8	MB8
40	50	60	112	85	60	25	205	170	20	15	M12	1/2	80	10,5	20208	KM8	MB8
40	50	60	117	100	60	25	205	170	20	15	M12	1/2	90	12,5	20308	KM8	MB8
40	50	60	117	100	60	25	205	170	20	15	M12	1/2	90	12,5	21308	KM8	MB8
40	50	60	112	85	60	25	205	170	20	15	M12	1/2	80	10,5	22208	KM8	MB8
40	50	60	117	100	60	25	205	170	20	15	M12	1/2	90	12,5	22308	KM8	MB8
45	55	60	114	87	60	25	205	170	20	15	M12	1/2	85	12,5	1209	KM9	MB9
45	55	70	133	105	70	28	255	210	23	18	M16	5/8	100	12,5	1309	KM9	MB9
45	55	60	114	87	60	25	205	170	20	15	M12	1/2	85	12,5	2209	KM9	MB9
45	55	70	133	105	70	28	255	210	23	18	M16	5/8	100	12,5	2309	KM9	MB9
45	55	60	114	87	60	25	205	170	20	15	M12	1/2	85	12,5	20209	KM9	MB9
45	55	70	133	105	70	28	255	210	23	18	M16	5/8	100	12,5	20309	KM9	MB9
45	55	70	133	105	70	28	255	210	23	18	M16	5/8	100	12,5	21309	KM9	MB9
45	55	60	114	87	60	25	205	170	20	15	M12	1/2	85	12,5	22209	KM9	MB9
45	55	70	133	105	70	28	255	210	23	18	M16	5/8	100	12,5	22309	KM9	MB9
50	60	60	117	100	60	25	205	170	20	15	M12	1/2	90	12,5	1210	KM10	MB10
50	60	70	139	110	70	30	255	210	23	18	M16	5/8	110	12,5	1310	KM10	MB10
50	60	60	117	100	60	25	205	170	20	15	M12	1/2	90	12,5	2210	KM10	MB10
50	60	70	139	110	70	30	255	210	23	18	M16	5/8	110	12,5	2310	KM10	MB10
50	60	60	117	100	60	25	205	170	20	15	M12	1/2	90	12,5	20210	KM10	MB10
50	60	70	139	110	70	30	255	210	23	18	M16	5/8	110	12,5	20310	KM10	MB10
50	60	70	139	110	70	30	255	210	23	18	M16	5/8	110	12,5	21310	KM10	MB10
50	60	60	117	100	60	25	205	170	20	15	M12	1/2	90	12,5	22210	KM10	MB10
50	60	70	139	110	70	30	255	210	23	18	M16	5/8	110	12,5	22310	KM10	MB10

① Locating bearing; ② Non-locating bearing

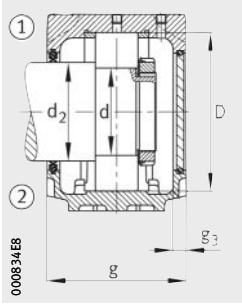

Double lip seal DH
Cover DKVT

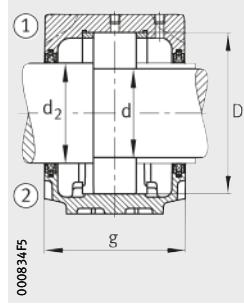

Felt seal FSV

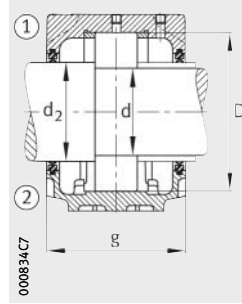

Double lip seal DH

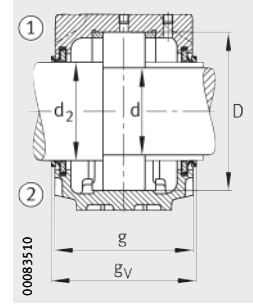

V ring seal DHV



										Housing	
Locating ring	Felt seal	Double lip seal	Labyrinth seal		V ring seal		Taconite seal		Cover	Mass m ≈ kg	Designation
				g _L mm		g _V mm		g _T mm			
Quantity 2											
FRM80/10,5	FSV208	DH208	TSV208	98	DHV208	93	-	-	DKV080	2,9	SNV080-F-L
FRM90/9	FSV308	DH308	TSV308	114	DHV308	106	-	-	DKV090	3,1	SNV090-F-L
FRM80/8	FSV208	DH208	TSV208	98	DHV208	93	-	-	DKV080	2,9	SNV080-F-L
FRM90/4	FSV308	DH308	TSV308	114	DHV308	106	-	-	DKV090	3,1	SNV090-F-L
FRM80/10,5	FSV208	DH208	TSV208	98	DHV208	93	-	-	DKV080	2,9	SNV080-F-L
FRM90/9	FSV308	DH308	TSV308	114	DHV308	106	-	-	DKV090	3,1	SNV090-F-L
FRM90/9	FSV308	DH308	TSV308	114	DHV308	106	-	-	DKV090	3,1	SNV090-F-L
FRM80/8	FSV208	DH208	TSV208	98	DHV208	93	-	-	DKV080	2,9	SNV080-F-L
FRM90/4	FSV308	DH308	TSV308	114	DHV308	106	-	-	DKV090	3,1	SNV090-F-L
FRM85/6	FSV209	DH209	TSV209	101	DHV209	93	-	-	DKV085	2,8	SNV085-F-L
FRM100/9,5	FSV309	DH309	TSV309	119	DHV309	111	-	-	DKV100	4,3	SNV100-F-L
FRM85/4	FSV209	DH209	TSV209	101	DHV209	93	-	-	DKV085	2,8	SNV085-F-L
FRM100/4	FSV309	DH309	TSV309	119	DHV309	111	-	-	DKV100	4,3	SNV100-F-L
FRM85/6	FSV209	DH209	TSV209	101	DHV209	93	-	-	DKV085	2,8	SNV085-F-L
FRM100/9,5	FSV309	DH309	TSV309	119	DHV309	111	-	-	DKV100	4,3	SNV100-F-L
FRM100/9,5	FSV309	DH309	TSV309	119	DHV309	111	-	-	DKV100	4,3	SNV100-F-L
FRM85/4	FSV209	DH209	TSV209	101	DHV209	93	-	-	DKV085	2,8	SNV085-F-L
FRM100/4	FSV309	DH309	TSV309	119	DHV309	111	-	-	DKV100	4,3	SNV100-F-L
FRM90/10,5	FSV210	DH210	TSV210	114	DHV210	106	-	-	DKV090	3,1	SNV090-F-L
FRM110/10,5	FSV310	DH310	TSV310	124	DHV310	116	-	-	DKV110	4,9	SNV110-F-L
FRM90/9	FSV210	DH210	TSV210	114	DHV210	106	-	-	DKV090	3,1	SNV090-F-L
FRM110/4	FSV310	DH310	TSV310	124	DHV310	116	-	-	DKV110	4,9	SNV110-F-L
FRM90/10,5	FSV210	DH210	TSV210	114	DHV210	106	-	-	DKV090	3,1	SNV090-F-L
FRM110/10,5	FSV310	DH310	TSV310	124	DHV310	116	-	-	DKV110	4,9	SNV110-F-L
FRM110/10,5	FSV310	DH310	TSV310	124	DHV310	116	-	-	DKV110	4,9	SNV110-F-L
FRM90/9	FSV210	DH210	TSV210	114	DHV210	106	-	-	DKV090	3,1	SNV090-F-L
FRM110/4	FSV310	DH310	TSV310	124	DHV310	116	-	-	DKV110	4,9	SNV110-F-L

Plummer block housings

SNV, split
For bearings
with cylindrical bore
Metric shaft

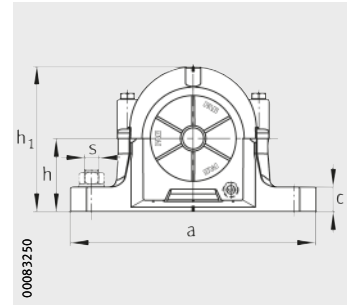
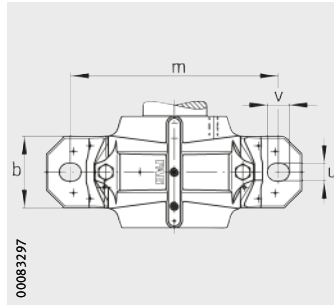

Dimension table (continued) · Dimensions in mm

Shaft		Housing Dimensions												Bearing and accessories			
d	d ₂	h	h ₁	g	b	c	a	m	v	u	s		D	g ₃	Bearing	Lock-nut	Tab washer
											mm	inch					
55	65	70	133	105	70	28	255	210	23	18	M16	5/8	100	12,5	1211	KM11	MB11
55	65	80	155	115	80	30	275	230	23	18	M16	5/8	120	12,5	1311	KM11	MB11
55	65	70	133	105	70	28	255	210	23	18	M16	5/8	100	12,5	2211	KM11	MB11
55	65	80	155	115	80	30	275	230	23	18	M16	5/8	120	12,5	2311	KM11	MB11
55	65	70	133	105	70	28	255	210	23	18	M16	5/8	100	12,5	20211	KM11	MB11
55	65	80	155	115	80	30	275	230	23	18	M16	5/8	120	12,5	20311	KM11	MB11
55	65	80	155	115	80	30	275	230	23	18	M16	5/8	120	12,5	21311	KM11	MB11
55	65	70	133	105	70	28	255	210	23	18	M16	5/8	100	12,5	22211	KM11	MB11
55	65	80	155	115	80	30	275	230	23	18	M16	5/8	120	12,5	22311	KM11	MB11
60	70	70	139	110	70	30	255	210	23	18	M16	5/8	110	12,5	1212	KM12	MB12
60	70	80	161	120	80	30	280	230	23	18	M16	5/8	130	12,5	1312	KM12	MB12
60	70	70	139	110	70	30	255	210	23	18	M16	5/8	110	12,5	2212	KM12	MB12
60	70	80	161	120	80	30	280	230	23	18	M16	5/8	130	12,5	2312	KM12	MB12
60	70	70	139	110	70	30	255	210	23	18	M16	5/8	110	12,5	20212	KM12	MB12
60	70	80	161	120	80	30	280	230	23	18	M16	5/8	130	12,5	20312	KM12	MB12
60	70	80	161	120	80	30	280	230	23	18	M16	5/8	130	12,5	21312	KM12	MB12
60	70	70	139	110	70	30	255	210	23	18	M16	5/8	110	12,5	22212	KM12	MB12
60	70	80	161	120	80	30	280	230	23	18	M16	5/8	130	12,5	22312	KM12	MB12
65	75	80	155	115	80	30	275	230	23	18	M16	5/8	120	12,5	1213	KM13	MB13
65	75	95	183	135	90	32	315	260	27	22	M20	3/4	140	15	1313	KM13	MB13
65	75	80	155	115	80	30	275	230	23	18	M16	5/8	120	12,5	2213	KM13	MB13
65	75	95	183	135	90	32	315	260	27	22	M20	3/4	140	15	2313	KM13	MB13
65	75	80	155	115	80	30	275	230	23	18	M16	5/8	120	12,5	20213	KM13	MB13
65	75	95	183	135	90	32	315	260	27	22	M20	3/4	140	15	20313	KM13	MB13
65	75	95	183	135	90	32	315	260	27	22	M20	3/4	140	15	21313	KM13	MB13
65	75	80	155	115	80	30	275	230	23	18	M16	5/8	120	12,5	22213	KM13	MB13
65	75	95	183	135	90	32	315	260	27	22	M20	3/4	140	15	22313	KM13	MB13

① Locating bearing; ② Non-locating bearing

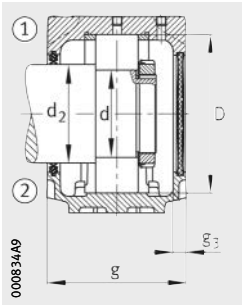

Double lip seal DH
Cover DKV

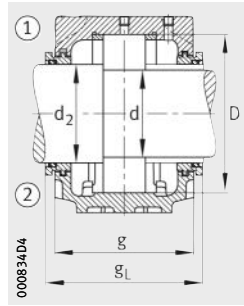

Labyrinth seal TSV

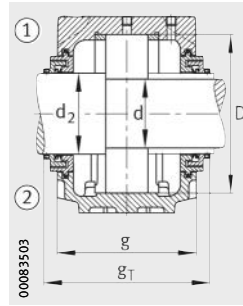

Taconite seal TCV

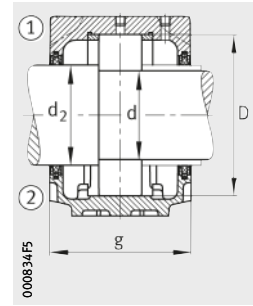

Felt seal FSV



										Housing	
Locating ring	Felt seal	Double lip seal	Labyrinth seal		V ring seal		Taconite seal		Cover	Mass	Designation
Quantity 2				g _L mm		g _V mm		g _T mm		m ≈ kg	
FRM100/11,5	FSV211	DH211	TSV211	119	DHV211	111	–	–	DKV100	4,3	SNV100-F-L
FRM120/11	FSV311	DH311	TSV311	129	DHV311	121	–	–	DKV120	6,1	SNV120-F-L
FRM100/9,5	FSV211	DH211	TSV211	119	DHV211	111	–	–	DKV100	4,3	SNV100-F-L
FRM120/4	FSV311	DH311	TSV311	129	DHV311	121	–	–	DKV120	6,1	SNV120-F-L
FRM100/11,5	FSV211	DH211	TSV211	119	DHV211	111	–	–	DKV100	4,3	SNV100-F-L
FRM120/11	FSV311	DH311	TSV311	129	DHV311	121	–	–	DKV120	6,1	SNV120-F-L
FRM120/11	FSV311	DH311	TSV311	129	DHV311	121	–	–	DKV120	6,1	SNV120-F-L
FRM100/9,5	FSV211	DH211	TSV211	119	DHV211	111	–	–	DKV100	4,3	SNV100-F-L
FRM120/4	FSV311	DH311	TSV311	129	DHV311	121	–	–	DKV120	6,1	SNV120-F-L
FRM110/13	FSV212	DH212	TSV212	124	DHV212	120	–	–	DKV110	4,9	SNV110-F-L
FRM130/12,5	FSV312	DH312	TSV312	134	DHV312	130	TCV312	158	DKV130	6,8	SNV130-F-L
FRM110/10	FSV212	DH212	TSV212	124	DHV212	120	–	–	DKV110	4,9	SNV110-F-L
FRM130/5	FSV312	DH312	TSV312	134	DHV312	130	TCV312	158	DKV130	6,8	SNV130-F-L
FRM110/13	FSV212	DH212	TSV212	124	DHV212	120	–	–	DKV110	4,9	SNV110-F-L
FRM130/12,5	FSV312	DH312	TSV312	134	DHV312	130	TCV312	158	DKV130	6,8	SNV130-F-L
FRM130/12,5	FSV312	DH312	TSV312	134	DHV312	130	TCV312	158	DKV130	6,8	SNV130-F-L
FRM110/10	FSV212	DH212	TSV212	124	DHV212	120	–	–	DKV110	4,9	SNV110-F-L
FRM130/5	FSV312	DH312	TSV312	134	DHV312	130	TCV312	158	DKV130	6,8	SNV130-F-L
FRM120/14	FSV213	DH213	TSV213	129	DHV213	125	–	–	DKV120	6,1	SNV120-F-L
FRM140/12,5	FSV313	DH313	TSV313	150,3	DHV313	142,5	TCV313	175,5	DKV140	9,3	SNV140-F-L
FRM120/10	FSV213	DH213	TSV213	129	DHV213	125	–	–	DKV120	6,1	SNV120-F-L
FRM140/5	FSV313	DH313	TSV313	150,3	DHV313	142,5	TCV313	175,5	DKV140	9,3	SNV140-F-L
FRM120/14	FSV213	DH213	TSV213	129	DHV213	125	–	–	DKV120	6,1	SNV120-F-L
FRM140/12,5	FSV313	DH313	TSV313	150,3	DHV313	142,5	TCV313	175,5	DKV140	9,3	SNV140-F-L
FRM140/12,5	FSV313	DH313	TSV313	150,3	DHV313	142,5	TCV313	175,5	DKV140	9,3	SNV140-F-L
FRM140/12,5	FSV313	DH313	TSV313	150,3	DHV313	142,5	TCV313	175,5	DKV140	9,3	SNV140-F-L
FRM120/10	FSV213	DH213	TSV213	129	DHV213	125	–	–	DKV120	6,1	SNV120-F-L
FRM140/5	FSV313	DH313	TSV313	150,3	DHV313	142,5	TCV313	175,5	DKV140	9,3	SNV140-F-L

Plummer block housings

SNV, split
For bearings
with cylindrical bore
Metric shaft

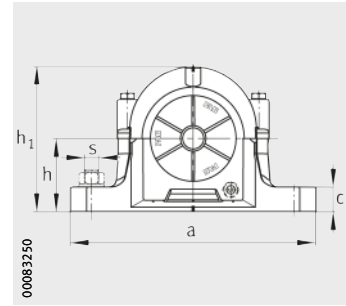
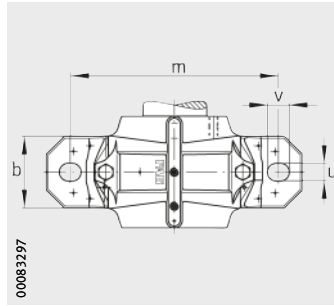

Dimension table (continued) · Dimensions in mm

Shaft		Housing Dimensions													Bearing and accessories		
d	d ₂	h	h ₁	g	b	c	a	m	v	u	s		D	g ₃	Bearing	Lock-nut	Tab washer
											mm	inch					
70	80	80	158	105	80	30	275	230	23	18	M16	5/8	125	15	1214	KM14	MB14
70	80	95	189	140	90	32	320	260	27	22	M20	3/4	150	15	1314	KM14	MB14
70	80	80	158	105	80	30	275	230	23	18	M16	5/8	125	15	2214	KM14	MB14
70	80	95	189	140	90	32	320	260	27	22	M20	3/4	150	15	2314	KM14	MB14
70	80	80	158	105	80	30	275	230	23	18	M16	5/8	125	15	20214	KM14	MB14
70	80	95	189	140	90	32	320	260	27	22	M20	3/4	150	15	20314	KM14	MB14
70	80	95	189	140	90	32	320	260	27	22	M20	3/4	150	15	21314	KM14	MB14
70	80	80	158	105	80	30	275	230	23	18	M16	5/8	125	15	22214	KM14	MB14
70	80	95	189	140	90	32	320	260	27	22	M20	3/4	150	15	22314	KM14	MB14
75	85	80	161	120	80	30	280	230	23	18	M16	5/8	130	12,5	1215	KM15	MB15
75	85	100	201	145	100	35	345	290	27	22	M20	3/4	160	15	1315	KM15	MB15
75	85	80	161	120	80	30	280	230	23	18	M16	5/8	130	12,5	2215	KM15	MB15
75	85	100	201	145	100	35	345	290	27	22	M20	3/4	160	15	2315	KM15	MB15
75	85	80	161	120	80	30	280	230	23	18	M16	5/8	130	12,5	20215	KM15	MB15
75	85	100	201	145	100	35	345	290	27	22	M20	3/4	160	15	20315	KM15	MB15
75	85	100	201	145	100	35	345	290	27	22	M20	3/4	160	15	21315	KM15	MB15
75	85	80	161	120	80	30	280	230	23	18	M16	5/8	130	12,5	22215	KM15	MB15
75	85	100	201	145	100	35	345	290	27	22	M20	3/4	160	15	22315	KM15	MB15
80	90	95	183	135	90	32	315	260	27	22	M20	3/4	140	15	1216	KM16	MB16
80	90	112	219	150	100	35	345	290	27	22	M20	3/4	170	16	1316	KM16	MB16
80	90	95	183	135	90	32	315	260	27	22	M20	3/4	140	15	2216	KM16	MB16
80	90	112	219	150	100	35	345	290	27	22	M20	3/4	170	16	2316	KM16	MB16
80	90	95	183	135	90	32	315	260	27	22	M20	3/4	140	15	20216	KM16	MB16
80	90	112	219	150	100	35	345	290	27	22	M20	3/4	170	16	20316	KM16	MB16
80	90	112	219	150	100	35	345	290	27	22	M20	3/4	170	16	21316	KM16	MB16
80	90	95	183	135	90	32	315	260	27	22	M20	3/4	140	15	22216	KM16	MB16
80	90	112	219	150	100	35	345	290	27	22	M20	3/4	170	16	22316	KM16	MB16

① Locating bearing; ② Non-locating bearing

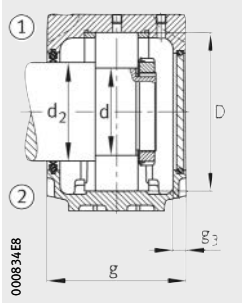

Double lip seal DH
Cover DKVT

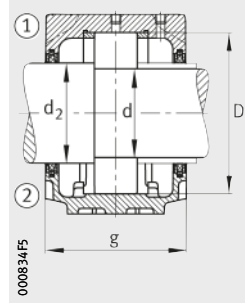

Felt seal FSV

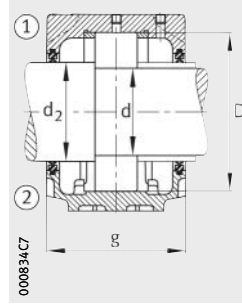

Double lip seal DH

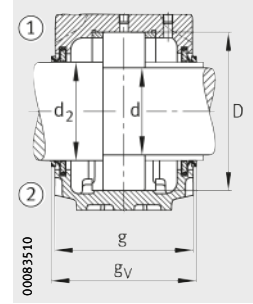

V ring seal DHV



										Housing	
Locating ring	Felt seal	Double lip seal	Labyrinth seal		V ring seal		Taconite seal		Cover	Mass m ≈ kg	Designation
				gL mm		gv mm		gr mm			
Quantity 2											
FRM125/7,5	FSV214	DH214	TSV214	120,3	DHV214	110	TCV214	143	DKV150	6,5	SNV125-F-L
FRM150/13	FSV214	DH214	TSV214	155,3	DHV214	147,5	TCV214	180,5	DKV150	9,9	SNV150-F-L
FRM125/4	FSV214	DH214	TSV214	120,3	DHV214	110	TCV214	143	DKV150	6,5	SNV125-F-L
FRM150/5	FSV214	DH214	TSV214	155,3	DHV214	147,5	TCV214	180,5	DKV150	9,9	SNV150-F-L
FRM125/7,5	FSV214	DH214	TSV214	120,3	DHV214	110	TCV214	143	DKV150	6,5	SNV125-F-L
FRM150/13	FSV214	DH214	TSV214	155,3	DHV214	147,5	TCV214	180,5	DKV150	9,9	SNV150-F-L
FRM150/13	FSV214	DH214	TSV214	155,3	DHV214	147,5	TCV214	180,5	DKV150	9,9	SNV150-F-L
FRM125/4	FSV214	DH214	TSV214	120,3	DHV214	110	TCV214	143	DKV150	6,5	SNV125-F-L
FRM150/5	FSV214	DH214	TSV214	155,3	DHV214	147,5	TCV214	180,5	DKV150	9,9	SNV150-F-L
FRM130/15,5	FSV215	DH215	TSV215	134	DHV215	130	–	–	DKV130	6,8	SNV130-F-L
FRM160/14	FSV315	DH315	TSV315	160,3	DHV315	152,5	TCV315	185,5	DKV160	12,8	SNV160-F-L
FRM130/12,5	FSV215	DH215	TSV215	134	DHV215	130	–	–	DKV130	6,8	SNV130-F-L
FRM160/5	FSV315	DH315	TSV315	160,3	DHV315	152,5	TCV315	185,5	DKV160	12,8	SNV160-F-L
FRM130/15,5	FSV215	DH215	TSV215	134	DHV215	130	–	–	DKV130	6,8	SNV130-F-L
FRM160/14	FSV315	DH315	TSV315	160,3	DHV315	152,5	TCV315	185,5	DKV160	12,8	SNV160-F-L
FRM160/14	FSV315	DH315	TSV315	160,3	DHV315	152,5	TCV315	185,5	DKV160	12,8	SNV160-F-L
FRM130/12,5	FSV215	DH215	TSV215	134	DHV215	130	–	–	DKV130	6,8	SNV130-F-L
FRM160/5	FSV315	DH315	TSV315	160,3	DHV315	152,5	TCV315	185,5	DKV160	12,8	SNV160-F-L
FRM140/16	FSV216	DH216	TSV216	150,3	DHV216	142,5	–	–	DKV140	9,3	SNV140-F-L
FRM170/14,5	FSV316	DH316	TSV316	167,3	DHV316	157,5	TCV316	192,5	DKV170	14,4	SNV170-F-L
FRM140/12,5	FSV216	DH216	TSV216	150,3	DHV216	142,5	–	–	DKV140	9,3	SNV140-F-L
FRM170/5	FSV316	DH316	TSV316	167,3	DHV316	157,5	TCV316	192,5	DKV170	14,4	SNV170-F-L
FRM140/16	FSV216	DH216	TSV216	150,3	DHV216	142,5	–	–	DKV140	9,3	SNV140-F-L
FRM170/14,5	FSV316	DH316	TSV316	167,3	DHV316	157,5	TCV316	192,5	DKV170	14,4	SNV170-F-L
FRM170/14,5	FSV316	DH316	TSV316	167,3	DHV316	157,5	TCV316	192,5	DKV170	14,4	SNV170-F-L
FRM170/14,5	FSV316	DH316	TSV316	167,3	DHV316	157,5	TCV316	192,5	DKV170	14,4	SNV170-F-L
FRM140/12,5	FSV216	DH216	TSV216	150,3	DHV216	142,5	–	–	DKV140	9,3	SNV140-F-L
FRM170/5	FSV316	DH316	TSV316	167,3	DHV316	157,5	TCV316	192,5	DKV170	14,4	SNV170-F-L

Plummer block housings

SNV, split
For bearings
with cylindrical bore
Metric shaft

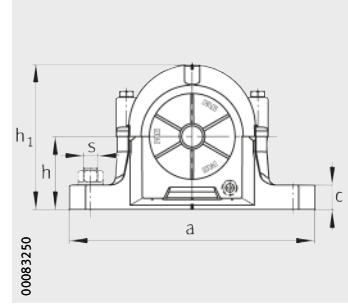
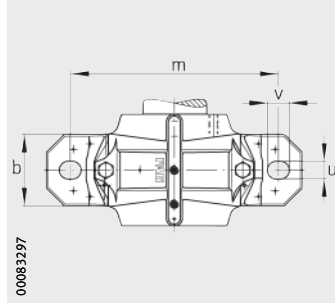

Dimension table (continued) · Dimensions in mm

Shaft		Housing Dimensions													Bearing and accessories		
d	d ₂	h	h ₁	g	b	c	a	m	v	u	s		D	g ₃	Bearing	Lock-nut	Tab washer
											mm	inch					
85	95	95	189	140	90	32	320	260	27	22	M20	3/4	150	15	1217	KM17	MB17
85	95	112	223	160	110	40	380	320	32	26	M24	7/8	180	16	1317	KM17	MB17
85	95	95	189	140	90	32	320	260	27	22	M20	3/4	150	15	2217	KM17	MB17
85	95	112	223	160	110	40	380	320	32	26	M24	7/8	180	16	2317	KM17	MB17
85	95	95	189	140	90	32	320	260	27	22	M20	3/4	150	15	20217	KM17	MB17
85	95	112	223	160	110	40	380	320	32	26	M24	7/8	180	16	20317	KM17	MB17
85	95	112	223	160	110	40	380	320	32	26	M24	7/8	180	16	21317	KM17	MB17
85	95	95	189	140	90	32	320	260	27	22	M20	3/4	150	15	22217	KM17	MB17
85	95	112	223	160	110	40	380	320	32	26	M24	7/8	180	16	22317	KM17	MB17
90	100	100	201	145	100	35	345	290	27	22	M20	3/4	160	15	1218	KM18	MB18
90	105	112	229	155	110	40	380	320	32	26	M24	7/8	190	15	1318	KM18	MB18
90	100	100	201	145	100	35	345	290	27	22	M20	3/4	160	15	2218	KM18	MB18
90	105	112	229	155	110	40	380	320	32	26	M24	7/8	190	15	2318	KM18	MB18
90	100	100	201	145	100	35	345	290	27	22	M20	3/4	160	15	20218	KM18	MB18
90	105	112	229	155	110	40	380	320	32	26	M24	7/8	190	15	20318	KM18	MB18
90	105	112	229	155	110	40	380	320	32	26	M24	7/8	190	15	21318	KM18	MB18
90	100	100	201	145	100	35	345	290	27	22	M20	3/4	160	15	22218	KM18	MB18
90	105	112	229	155	110	40	380	320	32	26	M24	7/8	190	15	22318	KM18	MB18
90	100	100	201	145	100	35	345	290	27	22	M20	3/4	160	15	23218	KM18	MB18
95	110	112	219	150	100	35	345	290	27	22	M20	3/4	170	16	1219	KM19	MB19
95	110	125	248	175	120	45	410	350	32	26	M24	7/8	200	16	1319	KM19	MB19
95	110	112	219	150	100	35	345	290	27	22	M20	3/4	170	16	2219	KM19	MB19
95	110	125	248	175	120	45	410	350	32	26	M24	7/8	200	16	2319	KM19	MB19
95	110	112	219	150	100	35	345	290	27	22	M20	3/4	170	16	20219	KM19	MB19
95	110	125	248	175	120	45	410	350	32	26	M24	7/8	200	16	20319	KM19	MB19
95	110	125	248	175	120	45	410	350	32	26	M24	7/8	200	16	21319	KM19	MB19
95	110	112	219	150	100	35	345	290	27	22	M20	3/4	170	16	22219	KM19	MB19
95	110	125	248	175	120	45	410	350	32	26	M24	7/8	200	16	22319	KM19	MB19

① Locating bearing; ② Non-locating bearing

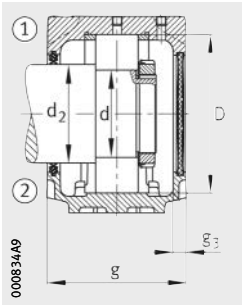

Double lip seal DH
Cover DKV

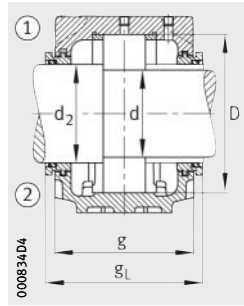

Labyrinth seal TSV

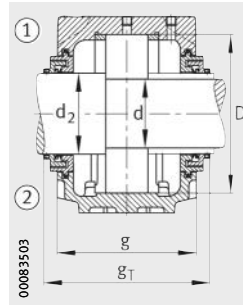

Taconite seal TCV

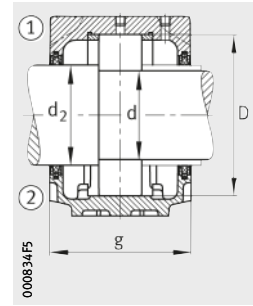

Felt seal FSV



										Housing	
Locating ring	Felt seal	Double lip seal	Labyrinth seal		V ring seal		Taconite seal		Cover	Mass	Designation
Quantity 2				g _L mm		g _v mm		g _T mm		m ≈ kg	
FRM150/16,5	FSV217	DH217	TSV217	155,3	DHV217	137,5	-	-	DKV150	9,9	SNV150-F-L
FRM180/14,5	FSV317	DH317	TSV317	177,3	DHV317	167,5	TCV317	202,5	DKV180	17	SNV180-F-L
FRM150/12,5	FSV217	DH217	TSV217	155,3	DHV217	137,5	-	-	DKV150	9,9	SNV150-F-L
FRM180/5	FSV317	DH317	TSV317	177,3	DHV317	167,5	TCV317	202,5	DKV180	17	SNV180-F-L
FRM150/16,5	FSV217	DH217	TSV217	155,3	DHV217	137,5	-	-	DKV150	9,9	SNV150-F-L
FRM180/14,5	FSV317	DH317	TSV317	177,3	DHV317	167,5	TCV317	202,5	DKV180	17	SNV180-F-L
FRM180/14,5	FSV317	DH317	TSV317	177,3	DHV317	167,5	TCV317	202,5	DKV180	17	SNV180-F-L
FRM150/12,5	FSV217	DH217	TSV217	155,3	DHV217	137,5	-	-	DKV150	9,9	SNV150-F-L
FRM180/5	FSV317	DH317	TSV317	177,3	DHV317	167,5	TCV317	202,5	DKV180	17	SNV180-F-L
FRM160/17,5	FSV218	DH218	TSV218	160,3	DHV218	152,5	-	-	DKV160	12,8	SNV160-F-L
FRM190/15,5	FSV318	DH318	TSV318	170,3	DHV318	162,5	-	-	DKV160	22	SNV190-F-L
FRM160/12,5	FSV218	DH218	TSV218	160,3	DHV218	152,5	-	-	DKV160	12,8	SNV160-F-L
FRM190/5	FSV318	DH318	TSV318	170,3	DHV318	162,5	-	-	DKV160	22	SNV190-F-L
FRM160/17,5	FSV218	DH218	TSV218	160,3	DHV218	152,5	-	-	DKV160	12,8	SNV160-F-L
FRM190/15,5	FSV318	DH318	TSV318	170,3	DHV318	162,5	-	-	DKV160	22	SNV190-F-L
FRM190/15,5	FSV318	DH318	TSV318	170,3	DHV318	162,5	-	-	DKV160	22	SNV190-F-L
FRM160/12,5	FSV218	DH218	TSV218	160,3	DHV218	152,5	-	-	DKV160	12,8	SNV160-F-L
FRM190/5	FSV318	DH318	TSV318	170,3	DHV318	162,5	-	-	DKV160	22	SNV190-F-L
FRM160/6,3	FSV218	DH218	TSV218	160,3	DHV218	152,5	-	-	DKV160	12,8	SNV160-F-L
FRM170/18	FSV219	DH219	TSV219	167,3	DHV219	160,5	-	-	DKV170	14,4	SNV170-F-L
FRM200/17,5	FSV319	DH319	TSV319	192,3	DHV319	185,5	TCV319	217,5	DKV200	21	SNV200-F-L
FRM170/12,5	FSV219	DH219	TSV219	167,3	DHV219	160,5	-	-	DKV170	14,4	SNV170-F-L
FRM200/6,5	FSV319	DH319	TSV319	192,3	DHV319	185,5	TCV319	217,5	DKV200	21	SNV200-F-L
FRM170/18	FSV219	DH219	TSV219	167,3	DHV219	160,5	-	-	DKV170	14,4	SNV170-F-L
FRM200/17,5	FSV319	DH319	TSV319	192,3	DHV319	185,5	TCV319	217,5	DKV200	21	SNV200-F-L
FRM200/17,5	FSV319	DH319	TSV319	192,3	DHV319	185,5	TCV319	217,5	DKV200	21	SNV200-F-L
FRM170/12,5	FSV219	DH219	TSV219	167,3	DHV219	160,5	-	-	DKV170	14,4	SNV170-F-L
FRM200/6,5	FSV319	DH319	TSV319	192,3	DHV319	185,5	TCV319	217,5	DKV200	21	SNV200-F-L

Plummer block housings

SNV, split
For bearings
with cylindrical bore
Metric shaft

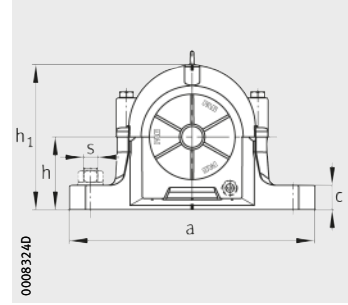
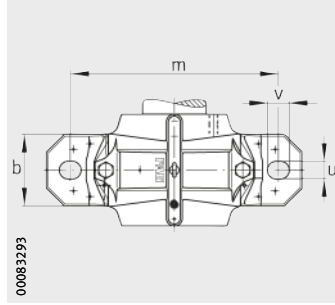

Dimension table (continued) · Dimensions in mm

Shaft		Housing Dimensions													Bearing and accessories		
d	d ₂	h	h ₁	g	b	c	a	m	v	u	s		D	g ₃	Bearing	Lock-nut	Tab washer
											mm	inch					
100	115	112	223	160	110	40	380	320	32	26	M24	7/8	180	16	1220	KM20	MB20
100	115	140	271	180	120	45	410	350	32	26	M24	7/8	215	16	1320	KM20	MB20
100	115	112	223	160	110	40	380	320	32	26	M24	7/8	180	16	2220	KM20	MB20
100	115	140	271	180	120	45	410	350	32	26	M24	7/8	215	16	2320	KM20	MB20
100	115	112	223	160	110	40	380	320	32	26	M24	7/8	180	16	20220	KM20	MB20
100	115	140	271	180	120	45	410	350	32	26	M24	7/8	215	16	20320	KM20	MB20
100	115	140	271	180	120	45	410	350	32	26	M24	7/8	215	16	21320	KM20	MB20
100	115	112	223	160	110	40	380	320	32	26	M24	7/8	180	16	22220	KM20	MB20
100	115	140	271	180	120	45	410	350	32	26	M24	7/8	215	16	22320	KM20	MB20
100	115	112	223	160	110	40	380	320	32	26	M24	7/8	180	16	23220	KM20	MB20
110	125	125	248	175	120	45	410	350	32	26	M24	7/8	200	16	1222	KM22	MB22
110	125	150	298	185	130	50	450	390	35	28	M24	1	240	18	1322	KM22	MB22
110	125	125	248	175	120	45	410	350	32	26	M24	7/8	200	16	2222	KM22	MB22
110	125	150	298	185	130	50	450	390	35	28	M24	1	240	18	2322	KM22	MB22
110	125	125	248	175	120	45	410	350	32	26	M24	7/8	200	16	20222	KM22	MB22
110	125	150	298	185	130	50	450	390	35	28	M24	1	240	18	20322	KM22	MB22
110	125	150	298	185	130	50	450	390	35	28	M24	1	240	18	21322	KM22	MB22
110	125	125	248	175	120	45	410	350	32	26	M24	7/8	200	16	22222	KM22	MB22
110	125	150	298	185	130	50	450	390	35	28	M24	1	240	18	22322	KM22	MB22
110	125	125	248	175	120	45	410	350	32	26	M24	7/8	200	16	23222	KM22	MB22
120	135	140	271	180	120	45	410	350	32	26	M24	7/8	215	16	20224	KM24	MB24
120	135	160	321	190	160	60	530	450	42	35	M30	1 1/4	260	18	20324	KM24	MB24
120	135	140	271	180	120	45	410	350	32	26	M24	7/8	215	16	22224	KM24	MB24
120	135	160	321	190	160	60	530	450	42	35	M30	1 1/4	260	18	22324	KM24	MB24
120	135	140	271	180	120	45	410	350	32	26	M24	7/8	215	16	23224	KM24	MB24
130	145	150	291	190	130	50	445	380	35	28	M24	1	230	18	20226	KM26	MB26
130	150	170	344	205	160	60	550	470	42	35	M30	1 1/4	280	18	20326	KM26	MB26
130	145	150	291	190	130	50	445	380	35	28	M24	1	230	18	22226	KM26	MB26
130	150	170	344	205	160	60	550	470	42	35	M30	1 1/4	280	18	22326	KM26	MB26
130	145	150	291	190	130	50	445	380	35	28	M24	1	230	18	23226	KM26	MB26

① Locating bearing; ② Non-locating bearing

1) Housing without eye bolt.

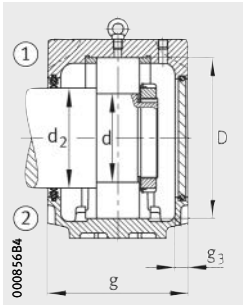

Double lip seal DH
Cover DKVT

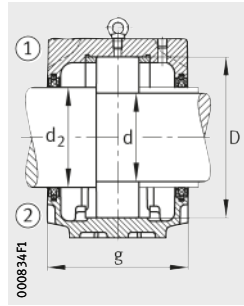

Felt seal FSV

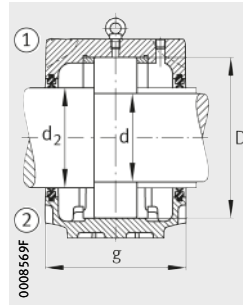

Double lip seal DH

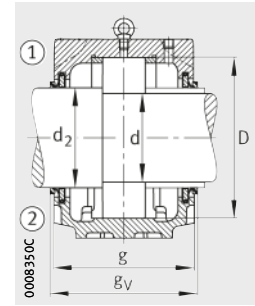

V ring seal DHV



										Housing	
Locating ring	Felt seal	Double lip seal	Labyrinth seal		V ring seal		Taconite seal		Cover	Mass	Designation
Quantity 2				g _L mm		g _v mm		g _T mm		m ≈ kg	
FRM180/18	FSV220	DH220	TSV220	177,3	DHV220	170,5	-	-	DKV180	17	SNV180-F-L ¹⁾
FRM215/19,5	FSV320	DH320	TSV320	197,3	DHV320	190,5	TCV320	226,5	DKV215	24,5	SNV215-F-L
FRM180/12	FSV220	DH220	TSV220	177,3	DHV220	170,5	-	-	DKV180	17	SNV180-F-L ¹⁾
FRM215/6,5	FSV320	DH320	TSV320	197,3	DHV320	190,5	TCV320	226,5	DKV215	24,5	SNV215-F-L
FRM180/18	FSV220	DH220	TSV220	177,3	DHV220	170,5	-	-	DKV180	17	SNV180-F-L ¹⁾
FRM215/19,5	FSV320	DH320	TSV320	197,3	DHV320	190,5	TCV320	226,5	DKV215	24,5	SNV215-F-L
FRM215/19,5	FSV320	DH320	TSV320	197,3	DHV320	190,5	TCV320	226,5	DKV215	24,5	SNV215-F-L
FRM180/12	FSV220	DH220	TSV220	177,3	DHV220	170,5	-	-	DKV180	17	SNV180-F-L ¹⁾
FRM215/6,5	FSV320	DH320	TSV320	197,3	DHV320	190,5	TCV320	226,5	DKV215	24,5	SNV215-F-L
FRM180/4,85	FSV220	DH220	TSV220	177,3	DHV220	170,5	-	-	DKV180	17	SNV180-F-L ¹⁾
FRM200/21	FSV222	DH222	TSV222	195,3	DHV222	185,5	-	-	DKV200	21	SNV200-F-L ¹⁾
FRM240/20	FSV222	DH222	TSV222	203,3	DHV222	193,5	-	-	DKV200	32	SNV240-F-L
FRM200/13,5	FSV222	DH222	TSV222	195,3	DHV222	185,5	-	-	DKV200	21	SNV200-F-L ¹⁾
FRM240/5	FSV222	DH222	TSV222	203,3	DHV222	193,5	-	-	DKV200	32	SNV240-F-L
FRM200/21	FSV222	DH222	TSV222	195,3	DHV222	185,5	-	-	DKV200	21	SNV200-F-L ¹⁾
FRM240/20	FSV222	DH222	TSV222	203,3	DHV222	193,5	-	-	DKV200	32	SNV240-F-L
FRM240/20	FSV222	DH222	TSV222	203,3	DHV222	193,5	-	-	DKV200	32	SNV240-F-L
FRM200/13,5	FSV222	DH222	TSV222	195,3	DHV222	185,5	-	-	DKV200	21	SNV200-F-L ¹⁾
FRM240/5	FSV222	DH222	TSV222	203,3	DHV222	193,5	-	-	DKV200	32	SNV240-F-L
FRM200/5,1	FSV222	DH222	TSV222	195,3	DHV222	185,5	-	-	DKV200	21	SNV200-F-L ¹⁾
FRM215/23	FSV224	DH224	TSV224	200,3	DHV224	190,5	-	-	DKV215	24,5	SNV215-F-L
FRM260/20,5	FSV224	DH224	TSV224	208,3	DHV224	198,5	-	-	DKV215	48	SNV260-F-L
FRM215/14	FSV224	DH224	TSV224	200,3	DHV224	190,5	-	-	DKV215	24,5	SNV215-F-L
FRM260/5	FSV224	DH224	TSV224	208,3	DHV224	198,5	-	-	DKV215	48	SNV260-F-L
FRM215/5	FSV224	DH224	TSV224	200,3	DHV224	190,5	-	-	DKV215	24,5	SNV215-F-L
FRM230/25	FSV226	DH226	TSV226	208,3	DHV226	198,5	-	-	DKV230	30	SNV230-F-L
FRM280/22,5	FSV326	DH326	TSV326	223,3	DHV326	213,5	-	-	DKV230	55	SNV280-F-L
FRM230/13	FSV226	DH226	TSV226	208,3	DHV226	198,5	-	-	DKV230	30	SNV230-F-L
FRM280/5	FSV326	DH326	TSV326	223,3	DHV326	213,5	-	-	DKV230	55	SNV280-F-L
FRM230/5	FSV226	DH226	TSV226	208,3	DHV226	198,5	-	-	DKV230	30	SNV230-F-L

Plummer block housings

SNV, split
For bearings with cylindrical bore
Metric shaft

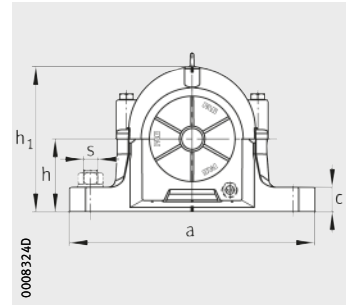
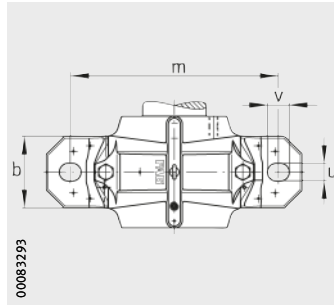

Dimension table (continued) · Dimensions in mm

Shaft		Housing Dimensions													Bearing and accessories		
d	d ₂	h	h ₁	g	b	c	a	m	v	u	s		D	g ₃	Bearing	Lock-nut	Tab washer
											mm	inch					
140	155	150	304	200	150	50	500	420	42	35	M30	1 1/4	250	18	20228	KM28	MB28
140	160	180	366	215	170	65	620	520	42	35	M30	1 1/4	300	18	20328	KM28	MB28
140	155	150	304	200	150	50	500	420	42	35	M30	1 1/4	250	18	22228	KM28	MB28
140	160	180	366	215	170	65	620	520	42	35	M30	1 1/4	300	18	22328	KM28	MB28
140	155	150	304	200	150	50	500	420	42	35	M30	1 1/4	250	18	23228	KM28	MB28
150	165	160	328	215	160	60	530	450	42	35	M30	1 1/4	270	18	20230	KM30	MB30
150	170	190	386	225	180	65	650	560	42	35	M30	1 1/4	320	18	20330	KM30	MB30
150	165	160	328	215	160	60	530	450	42	35	M30	1 1/4	270	18	22230	KM30	MB30
150	170	190	386	225	180	65	650	560	42	35	M30	1 1/4	320	18	22330	KM30	MB30
150	165	160	328	215	160	60	530	450	42	35	M30	1 1/4	270	18	23230	KM30	MB30
160	175	170	351	225	160	60	550	470	42	35	M30	1 1/4	290	18	20232	KM32	MB32
160	175	170	351	225	160	60	550	470	42	35	M30	1 1/4	290	18	22232	KM32	MB32
160	180	200	406	235	190	70	680	580	50	42	M36	1 1/4	340	18	22332	KM32	MB32
160	175	170	351	225	160	60	550	470	42	35	M30	1 1/4	290	18	23232	KM32	MB32

① Locating bearing; ② Non-locating bearing

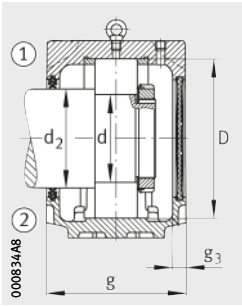

Double lip seal DH
Cover DKV

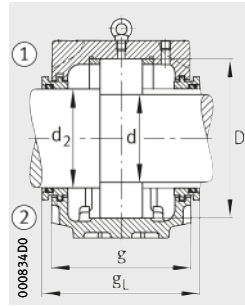

Labyrinth seal TSV

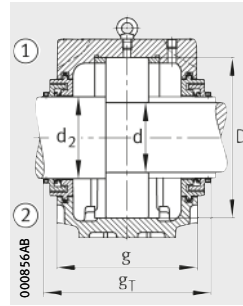

Taconite seal TCV

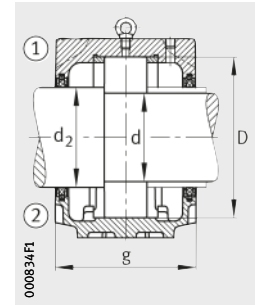

Felt seal FSV



									Housing		
Locating ring	Felt seal	Double lip seal	Labyrinth seal		V ring seal		Taconite seal		Cover	Mass m ≈ kg	Designation
Quantity 2				g _L mm		g _V mm		g _T mm			
FRM250/28	FSV228	DH228	TSV228	218,3	DHV228	211,5	-	-	DKV250	38	SNV250-F-L
FRM300/25	FSV328	DH328	TSV328	233,3	DHV328	226,5	-	-	DKV250	70	SNV300-F-L
FRM250/15	FSV228	DH228	TSV228	218,3	DHV228	211,5	-	-	DKV250	38	SNV250-F-L
FRM300/5	FSV328	DH328	TSV328	233,3	DHV328	226,5	-	-	DKV250	70	SNV300-F-L
FRM250/5	FSV228	DH228	TSV228	218,3	DHV228	211,5	-	-	DKV250	38	SNV250-F-L
FRM270/30,5	FSV230	DH230	TSV230	233,3	DHV230	228,5	-	-	DKV270	45,5	SNV270-F-L
FRM320/26,5	FSV330	DH330	TSV330	243,3	DHV330	236,5	-	-	DKV270	95	SNV320-F-L
FRM270/16,5	FSV230	DH230	TSV230	233,3	DHV230	228,5	-	-	DKV270	45,5	SNV270-F-L
FRM320/5	FSV330	DH330	TSV330	243,3	DHV330	236,5	-	-	DKV270	95	SNV320-F-L
FRM270/5	FSV230	DH230	TSV230	233,3	DHV230	228,5	-	-	DKV270	45,5	SNV270-F-L
FRM290/33	FSV232	DH232	TSV232	243,3	DHV232	236,5	-	-	DKV290	53,8	SNV290-F-L
FRM290/17	FSV232	DH232	TSV232	243,3	DHV232	236,5	-	-	DKV290	53,8	SNV290-F-L
FRM340/5	FSV332	DH332	TSV332	253,3	DHV332	246,5	-	-	DKV290	115	SNV340-F-L
FRM290/5	FSV232	DH232	TSV232	243,3	DHV232	236,5	-	-	DKV290	53,8	SNV290-F-L

Plummer block housings

SNV, split
For bearings with tapered bore and adapter sleeve
Inch size shaft

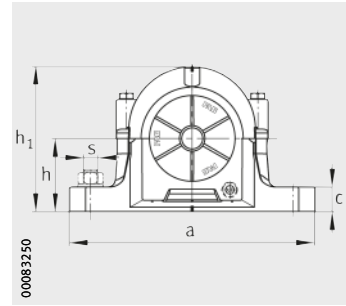
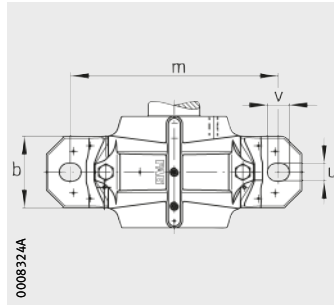

Dimension table - Dimensions in mm and inch

Shaft		Housing Dimensions													Bearing and accessories		
		h	h ₁	g	b	c	a	m	v	u	s		D	g ₃	Bearing	Adapter sleeve	Locating ring
inch	mm										mm	inch					Quantity 2
12/16	19,05	40	75	70	46	19	165	130	20	15	M12	1/2	52	10,5	1205-K	H205X012	FRM52/6
12/16	19,05	50	91	75	52	22	185	150	20	15	M12	1/2	62	10,5	1305-K	H305X012	FRM62/6,5
12/16	19,05	40	75	70	46	19	165	130	20	15	M12	1/2	52	10,5	20205-K	H205X012	FRM52/6
12/16	19,05	40	75	70	46	19	165	130	20	15	M12	1/2	52	10,5	2205-K	H305X012	FRM52/4,5
12/16	19,05	40	75	70	46	19	165	130	20	15	M12	1/2	52	10,5	22205...K	H305X012	FRM52/4,5
12/16	19,05	50	91	75	52	22	185	150	20	15	M12	1/2	62	10,5	2305-K	H2305X012	FRM62/3
13/16	20,638	40	75	70	46	19	165	130	20	15	M12	1/2	52	10,5	1205-K	H205X013	FRM52/6
13/16	20,638	40	75	70	46	19	165	130	20	15	M12	1/2	52	10,5	20205-K	H205X013	FRM52/6
13/16	20,638	40	75	70	46	19	165	130	20	15	M12	1/2	52	10,5	2205-K	H305X013	FRM52/4,5
13/16	20,638	40	75	70	46	19	165	130	20	15	M12	1/2	52	10,5	22205...K	H305X013	FRM52/4,5
14/16	22,225	50	91	75	52	22	185	150	20	15	M12	1/2	62	10,5	1206-K	H206X014	FRM62/7
14/16	22,225	50	97	80	52	22	185	150	20	15	M12	1/2	72	10,5	1306-K	H306X014	FRM72/7
14/16	22,225	50	91	75	52	22	185	150	20	15	M12	1/2	62	10,5	20206-K	H206X014	FRM62/7
14/16	22,225	50	91	75	52	22	185	150	20	15	M12	1/2	62	10,5	2206-K	H306X014	FRM62/5
14/16	22,225	50	91	75	52	22	185	150	20	15	M12	1/2	62	10,5	22206...K	H306X014	FRM62/5
14/16	22,225	50	97	80	52	22	185	150	20	15	M12	1/2	72	10,5	2306-K	H2306X014	FRM72/3
15/16	23,813	50	91	75	52	22	185	150	20	15	M12	1/2	62	10,5	1206-K	H206X015	FRM62/7
15/16	23,813	50	97	80	52	22	185	150	20	15	M12	1/2	72	10,5	1306-K	H306X015	FRM72/7
15/16	23,813	50	91	75	52	22	185	150	20	15	M12	1/2	62	10,5	20206-K	H206X015	FRM62/7
15/16	23,813	50	91	75	52	22	185	150	20	15	M12	1/2	62	10,5	2206-K	H306X015	FRM62/5
15/16	23,813	50	91	75	52	22	185	150	20	15	M12	1/2	62	10,5	22206...K	H306X015	FRM62/5
15/16	23,813	50	97	80	52	22	185	150	20	15	M12	1/2	72	10,5	2306-K	H2306X015	FRM72/3
1	25,4	50	91	75	52	22	185	150	20	15	M12	1/2	62	10,5	1206-K	H206X100	FRM62/7
1	25,4	50	97	80	52	22	185	150	20	15	M12	1/2	72	10,5	1306-K	H306X100	FRM72/7
1	25,4	50	91	75	52	22	185	150	20	15	M12	1/2	62	10,5	20206-K	H206X100	FRM62/7
1	25,4	50	91	75	52	22	185	150	20	15	M12	1/2	62	10,5	2206-K	H306X100	FRM62/5
1	25,4	50	91	75	52	22	185	150	20	15	M12	1/2	62	10,5	22206...K	H306X100	FRM62/5
1	25,4	50	97	80	52	22	185	150	20	15	M12	1/2	72	10,5	2306-K	H2306X100	FRM72/3

① Locating bearing; ② Non-locating bearing

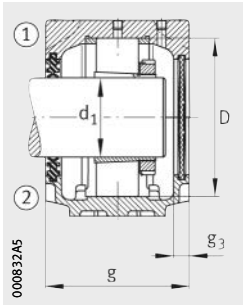

Double lip seal DH
Cover DKV

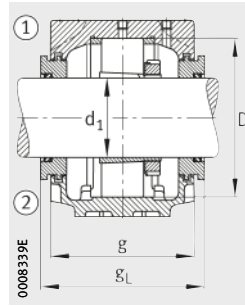

Labyrinth seal TSV

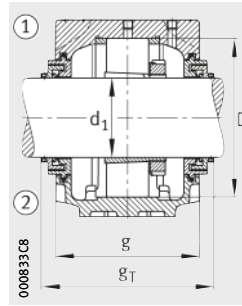

Tacanite seal TCV

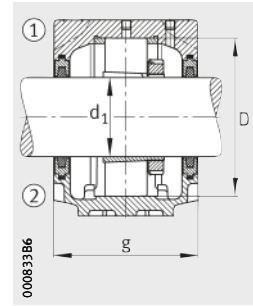

Felt seal FSV



									Housing	
Felt seal	Double lip seal	Labyrinth seal		Tacanite seal		V ring seal		Cover	Mass m ≈ kg	Designation
			gL mm		gT mm		gV mm			
FSV505X012	DH505X012	TSV505X012	83	–	–	DHV505X012	76	DKV052	1,3	SNV052-F-L
FSV605X012	DH605X012	TSV605X012	88	–	–	DHV605X012	81	DKV062	1,9	SNV062-F-L
FSV505X012	DH505X012	TSV505X012	83	–	–	DHV505X012	76	DKV052	1,3	SNV052-F-L
FSV505X012	DH505X012	TSV505X012	83	–	–	DHV505X012	76	DKV052	1,3	SNV052-F-L
FSV505X012	DH505X012	TSV505X012	83	–	–	DHV505X012	76	DKV052	1,3	SNV052-F-L
FSV605X012	DH605X012	TSV605X012	88	–	–	DHV605X012	81	DKV062	1,9	SNV062-F-L
FSV505	DH505	TSV505X013	83	–	–	DHV505	76	DKV052	1,3	SNV052-F-L
FSV505	DH505	TSV505X013	83	–	–	DHV505	76	DKV052	1,3	SNV052-F-L
FSV505	DH505	TSV505X013	83	–	–	DHV505	76	DKV052	1,3	SNV052-F-L
FSV505	DH505	TSV505X013	83	–	–	DHV505	76	DKV052	1,3	SNV052-F-L
FSV506X014	DH506X014	TSV506X014	88	–	–	DHV506X014	81	DKV062	1,9	SNV062-F-L
FSV606X014	DH606X014	TSV606X014	93	TCV606X014	117	DHV606X014	86	DKV072	2	SNV072-F-L
FSV506X014	DH506X014	TSV506X014	88	–	–	DHV506X014	81	DKV062	1,9	SNV062-F-L
FSV506X014	DH506X014	TSV506X014	88	–	–	DHV506X014	81	DKV062	1,9	SNV062-F-L
FSV506X014	DH506X014	TSV506X014	88	–	–	DHV506X014	81	DKV062	1,9	SNV062-F-L
FSV606X014	DH606X014	TSV606X014	93	TCV606X014	117	DHV606X014	86	DKV072	2	SNV072-F-L
FSV506X015	DH506X014	TSV506X015	88	–	–	DHV506X015	81	DKV062	1,9	SNV062-F-L
FSV606X015	DH606X014	TSV606X015	93	TCV606X015	117	DHV606X015	86	DKV072	2	SNV072-F-L
FSV506X015	DH506X014	TSV506X015	88	–	–	DHV506X015	81	DKV062	1,9	SNV062-F-L
FSV506X015	DH506X014	TSV506X015	88	–	–	DHV506X015	81	DKV062	1,9	SNV062-F-L
FSV506X015	DH506X014	TSV506X015	88	–	–	DHV506X015	81	DKV062	1,9	SNV062-F-L
FSV606X015	DH606X014	TSV606X015	93	TCV606X015	117	DHV606X015	86	DKV072	2	SNV072-F-L
FSV506	DH506	TSV506X100	88	–	–	DHV506	81	DKV062	1,9	SNV062-F-L
FSV606	DH606	TSV606X100	93	TCV606	117	DHV606	86	DKV072	2	SNV072-F-L
FSV506	DH506	TSV506X100	88	–	–	DHV506	81	DKV062	1,9	SNV062-F-L
FSV506	DH506	TSV506X100	88	–	–	DHV506	81	DKV062	1,9	SNV062-F-L
FSV506	DH506	TSV506X100	88	–	–	DHV506	81	DKV062	1,9	SNV062-F-L
FSV506	DH506	TSV506X100	88	–	–	DHV506	81	DKV062	1,9	SNV062-F-L
FSV606	DH606	TSV606X100	93	TCV606	117	DHV606	86	DKV072	2	SNV072-F-L

Plummer block housings

SNV, split
For bearings with tapered bore and adapter sleeve
Inch size shaft

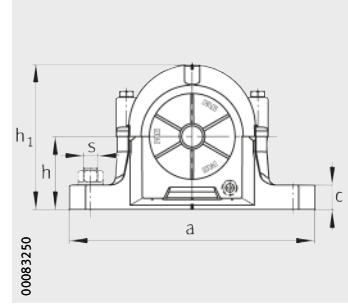
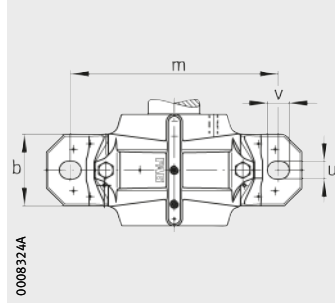

Dimension table (continued) · Dimensions in mm and inch

Shaft		Housing Dimensions											Bearing and accessories				
		h	h ₁	g	b	c	a	m	v	u	s	D	g ₃	Bearing	Adapter sleeve	Locating ring	
inch	mm										mm	inch				Quantity 2	
12/16	28,575	50	97	80	52	22	185	150	20	15	M12	1/2	72	10,5	1207-K	H207X102	FRM72/8
12/16	28,575	60	112	85	60	25	205	170	20	15	M12	1/2	80	10,5	1307-K	H307X102	FRM80/9
12/16	28,575	50	97	80	52	22	185	150	20	15	M12	1/2	72	10,5	20207-K	H207X102	FRM72/8
12/16	28,575	60	112	85	60	25	205	170	20	15	M12	1/2	80	10,5	21307..-K	H307X102	FRM80/9
12/16	28,575	50	97	80	52	22	185	150	20	15	M12	1/2	72	10,5	2207-K	H307X102	FRM72/5
12/16	28,575	50	97	80	52	22	185	150	20	15	M12	1/2	72	10,5	22207..-K	H307X102	FRM72/5
12/16	28,575	60	112	85	60	25	205	170	20	15	M12	1/2	80	10,5	2307-K	H2307X102	FRM80/4
13/16	30,163	50	97	80	52	22	185	150	20	15	M12	1/2	72	10,5	1207-K	H207X103	FRM72/8
13/16	30,163	60	112	85	60	25	205	170	20	15	M12	1/2	80	10,5	1307-K	H307X103	FRM80/9
13/16	30,163	50	97	80	52	22	185	150	20	15	M12	1/2	72	10,5	20207-K	H207X103	FRM72/8
13/16	30,163	60	112	85	60	25	205	170	20	15	M12	1/2	80	10,5	21307..-K	H307X103	FRM80/9
13/16	30,163	50	97	80	52	22	185	150	20	15	M12	1/2	72	10,5	2207-K	H307X103	FRM72/5
13/16	30,163	50	97	80	52	22	185	150	20	15	M12	1/2	72	10,5	22207..-K	H307X103	FRM72/5
13/16	30,163	60	112	85	60	25	205	170	20	15	M12	1/2	80	10,5	2307-K	H2307X103	FRM80/4
14/16	31,75	60	112	85	60	25	205	170	20	15	M12	1/2	80	10,5	1208-K	H208X104	FRM80/10,5
14/16	31,75	60	117	100	60	25	205	170	20	15	M12	1/2	90	12,5	1308-K	H308X104	FRM90/9
14/16	31,75	60	112	85	60	25	205	170	20	15	M12	1/2	80	10,5	20208-K	H208X104	FRM80/10,5
14/16	31,75	60	117	100	60	25	205	170	20	15	M12	1/2	90	12,5	21308..-K	H308X104	FRM90/9
14/16	31,75	60	112	85	60	25	205	170	20	15	M12	1/2	80	10,5	2208-K	H308X104	FRM80/8
14/16	31,75	60	112	85	60	25	205	170	20	15	M12	1/2	80	10,5	22208..-K	H308X104	FRM80/8
14/16	31,75	60	117	100	60	25	205	170	20	15	M12	1/2	90	12,5	22308..-K	H2308X104	FRM90/4
14/16	31,75	60	117	100	60	25	205	170	20	15	M12	1/2	90	12,5	2308-K	H2308X104	FRM90/4
15/16	33,338	60	112	85	60	25	205	170	20	15	M12	1/2	80	10,5	1208-K	H208X105	FRM80/10,5
15/16	33,338	60	117	100	60	25	205	170	20	15	M12	1/2	90	12,5	1308-K	H308X105	FRM90/9
15/16	33,338	60	112	85	60	25	205	170	20	15	M12	1/2	80	10,5	20208-K	H208X105	FRM80/10,5
15/16	33,338	60	117	100	60	25	205	170	20	15	M12	1/2	90	12,5	21308..-K	H308X105	FRM90/9
15/16	33,338	60	112	85	60	25	205	170	20	15	M12	1/2	80	10,5	2208-K	H308X105	FRM80/8
15/16	33,338	60	112	85	60	25	205	170	20	15	M12	1/2	80	10,5	22208..-K	H308X105	FRM80/8
15/16	33,338	60	117	100	60	25	205	170	20	15	M12	1/2	90	12,5	22308..-K	H2308X105	FRM90/4
15/16	33,338	60	117	100	60	25	205	170	20	15	M12	1/2	90	12,5	2308-K	H2308X105	FRM90/4

① Locating bearing; ② Non-locating bearing

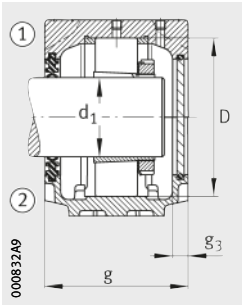

Double lip seal DH
Cover DKVT

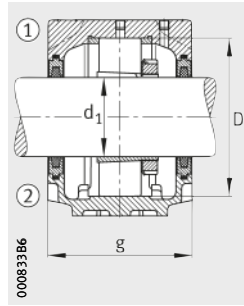

Felt seal FSV

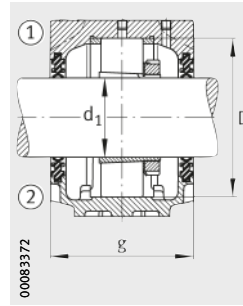

Double lip seal DH

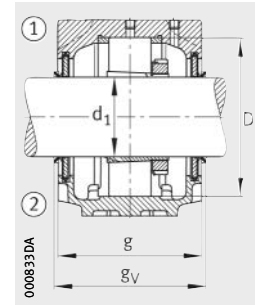

V ring seal DHV



									Housing	
Felt seal	Double lip seal	Labyrinth seal		Taconite seal		V ring seal		Cover	Mass m ≈ kg	Designation
			gL mm		gT mm		gv mm			
FSV507X102	DH507X102	TSV507X102	93	–	–	DHV507X102	86	DKV072	2	SNV072-F-L
FSV607X102	DH607X102	TSV607X102	98	TCV607X102	122	DHV607X102	91	DKV080	2,9	SNV080-F-L
FSV507X102	DH507X102	TSV507X102	93	–	–	DHV507X102	86	DKV072	2	SNV072-F-L
FSV607X102	DH607X102	TSV607X102	98	TCV607X102	122	DHV607X102	91	DKV080	2,9	SNV080-F-L
FSV507X102	DH507X102	TSV507X102	93	–	–	DHV507X102	86	DKV072	2	SNV072-F-L
FSV507X102	DH507X102	TSV507X102	93	–	–	DHV507X102	86	DKV072	2	SNV072-F-L
FSV607X102	DH607X102	TSV607X102	98	TCV607X102	122	DHV607X102	91	DKV080	2,9	SNV080-F-L
FSV507	DH507	TSV507	93	–	–	DHV507	86	DKV072	2	SNV072-F-L
FSV607	DH607	TSV607	98	TCV607	122	DHV607	91	DKV080	2,9	SNV080-F-L
FSV507	DH507	TSV507	93	–	–	DHV507	86	DKV072	2	SNV072-F-L
FSV607	DH607	TSV607	98	TCV607	122	DHV607	91	DKV080	2,9	SNV080-F-L
FSV507	DH507	TSV507	93	–	–	DHV507	86	DKV072	2	SNV072-F-L
FSV507	DH507	TSV507	93	–	–	DHV507	86	DKV072	2	SNV072-F-L
FSV607	DH607	TSV607	98	TCV607	122	DHV607	91	DKV080	2,9	SNV080-F-L
FSV508X104	DH508X104	TSV508X104	98	TCV508X104	122	DHV508X104	91	DKV080	2,9	SNV080-F-L
FSV608X104	DH608X104	TSV608X104	114	TCV608X104	136	DHV608X104	104	DKV090	3,1	SNV090-F-L
FSV508X104	DH508X104	TSV508X104	98	TCV508X104	122	DHV508X104	91	DKV080	2,9	SNV080-F-L
FSV608X104	DH608X104	TSV608X104	114	TCV608X104	136	DHV608X104	104	DKV090	3,1	SNV090-F-L
FSV508X104	DH508X104	TSV508X104	98	TCV508X104	122	DHV508X104	91	DKV080	2,9	SNV080-F-L
FSV508X104	DH508X104	TSV508X104	98	TCV508X104	122	DHV508X104	91	DKV080	2,9	SNV080-F-L
FSV608X104	DH608X104	TSV608X104	114	TCV608X104	136	DHV608X104	104	DKV090	3,1	SNV090-F-L
FSV608X104	DH608X104	TSV608X104	114	TCV608X104	136	DHV608X104	104	DKV090	3,1	SNV090-F-L
FSV508X105	DH508X104	TSV508X105	98	TCV508X105	122	DHV508X105	91	DKV080	2,9	SNV080-F-L
FSV608X105	DH608X104	TSV608X105	114	TCV608X105	136	DHV608X105	104	DKV090	3,1	SNV090-F-L
FSV508X105	DH508X104	TSV508X105	98	TCV508X105	122	DHV508X105	91	DKV080	2,9	SNV080-F-L
FSV608X105	DH608X104	TSV608X105	114	TCV608X105	136	DHV608X105	104	DKV090	3,1	SNV090-F-L
FSV508X105	DH508X104	TSV508X105	98	TCV508X105	122	DHV508X105	91	DKV080	2,9	SNV080-F-L
FSV508X105	DH508X104	TSV508X105	98	TCV508X105	122	DHV508X105	91	DKV080	2,9	SNV080-F-L
FSV608X105	DH608X104	TSV608X105	114	TCV608X105	136	DHV608X105	104	DKV090	3,1	SNV090-F-L
FSV608X105	DH608X104	TSV608X105	114	TCV608X105	136	DHV608X105	104	DKV090	3,1	SNV090-F-L

Plummer block housings

SNV, split
For bearings with tapered bore and adapter sleeve
Inch size shaft

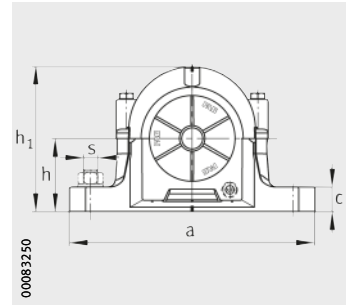
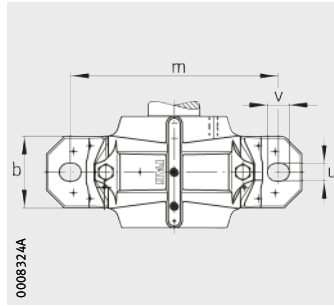

Dimension table (continued) · Dimensions in mm and *inch*

Shaft		Housing Dimensions													Bearing and accessories		
		h	h ₁	g	b	c	a	m	v	u	s		D	g ₃	Bearing	Adapter sleeve	Locating ring
<i>inch</i>	mm										mm	<i>inch</i>					Quantity 2
16/16	34,925	60	112	85	60	25	205	170	20	15	M12	1/2	80	10,5	1208-K	H208X106	FRM80/10,5
16/16	34,925	60	117	100	60	25	205	170	20	15	M12	1/2	90	12,5	1308-K	H308X106	FRM90/9
16/16	34,925	60	112	85	60	25	205	170	20	15	M12	1/2	80	10,5	20208-K	H208X106	FRM80/10,5
16/16	34,925	60	117	100	60	25	205	170	20	15	M12	1/2	90	12,5	21308..-K	H308X106	FRM90/9
16/16	34,925	60	112	85	60	25	205	170	20	15	M12	1/2	80	10,5	2208-K	H308X106	FRM80/8
16/16	34,925	60	112	85	60	25	205	170	20	15	M12	1/2	80	10,5	22208..-K	H308X106	FRM80/8
16/16	34,925	60	117	100	60	25	205	170	20	15	M12	1/2	90	12,5	22308..-K	H2308X106	FRM90/4
16/16	34,925	60	117	100	60	25	205	170	20	15	M12	1/2	90	12,5	2308-K	H2308X106	FRM90/4
17/16	36,513	60	114	87	60	25	205	170	20	15	M12	1/2	85	12,5	1209-K	H209X107	FRM85/6
17/16	36,513	70	133	105	70	28	255	210	23	18	M16	5/8	100	12,5	1309-K	H309X107	FRM100/9,5
17/16	36,513	60	114	87	60	25	205	170	20	15	M12	1/2	85	12,5	20209-K	H209X107	FRM85/6
17/16	36,513	70	133	105	70	28	255	210	23	18	M16	5/8	100	12,5	21309..-K	H309X107	FRM100/9,5
17/16	36,513	60	114	87	60	25	205	170	20	15	M12	1/2	85	12,5	2209-K	H309X107	FRM85/4
17/16	36,513	60	114	87	60	25	205	170	20	15	M12	1/2	85	12,5	22209..-K	H309X107	FRM85/4
17/16	36,513	70	133	105	70	28	255	210	23	18	M16	5/8	100	12,5	22309..-K	H2309X107	FRM100/4
17/16	36,513	70	133	105	70	28	255	210	23	18	M16	5/8	100	12,5	2309-K	H2309X107	FRM100/4
18/16	38,1	60	114	87	60	25	205	170	20	15	M12	1/2	85	12,5	1209-K	H209X108	FRM85/6
18/16	38,1	70	133	105	70	28	255	210	23	18	M16	5/8	100	12,5	1309-K	H309X108	FRM100/9,5
18/16	38,1	60	114	87	60	25	205	170	20	15	M12	1/2	85	12,5	20209-K	H209X108	FRM85/6
18/16	38,1	70	133	105	70	28	255	210	23	18	M16	5/8	100	12,5	21309..-K	H309X108	FRM100/9,5
18/16	38,1	60	114	87	60	25	205	170	20	15	M12	1/2	85	12,5	2209-K	H309X108	FRM85/4
18/16	38,1	60	114	87	60	25	205	170	20	15	M12	1/2	85	12,5	22209..-K	H309X108	FRM85/4
18/16	38,1	70	133	105	70	28	255	210	23	18	M16	5/8	100	12,5	22309..-K	H2309X108	FRM100/4
18/16	38,1	70	133	105	70	28	255	210	23	18	M16	5/8	100	12,5	2309-K	H2309X108	FRM100/4
19/16	39,688	70	133	105	70	28	255	210	23	18	M16	5/8	100	12,5	1309-K	H309X109	FRM100/9,5
19/16	39,688	70	133	105	70	28	255	210	23	18	M16	5/8	100	12,5	21309..-K	H309X109	FRM100/9,5
19/16	39,688	70	133	105	70	28	255	210	23	18	M16	5/8	100	12,5	22309..-K	H2309X109	FRM100/4
19/16	39,688	70	133	105	70	28	255	210	23	18	M16	5/8	100	12,5	2309-K	H2309X109	FRM100/4

① Locating bearing; ② Non-locating bearing

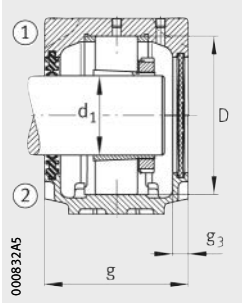

Double lip seal DH
Cover DKV

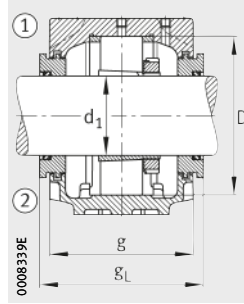

Labyrinth seal TSV

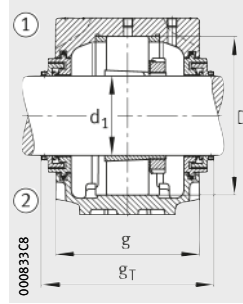

Taconite seal TCV

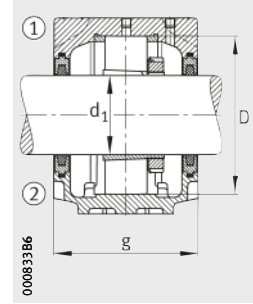

Felt seal FSV



									Housing	
Felt seal	Double lip seal	Labyrinth seal		Taconite seal		V ring seal		Cover	Mass m ≈ kg	Designation
			gL mm		gT mm		gV mm			
FSV508	DH508	TSV508	98	TCV508	122	DHV508	91	DKV080	2,9	SNV080-F-L
FSV608	DH608	TSV608	114	TCV608	136	DHV608	104	DKV090	3,1	SNV090-F-L
FSV508	DH508	TSV508	98	TCV508	122	DHV508	91	DKV080	2,9	SNV080-F-L
FSV608	DH608	TSV608	114	TCV608	136	DHV608	104	DKV090	3,1	SNV090-F-L
FSV508	DH508	TSV508	98	TCV508	122	DHV508	91	DKV080	2,9	SNV080-F-L
FSV508	DH508	TSV508	98	TCV508	122	DHV508	91	DKV080	2,9	SNV080-F-L
FSV608	DH608	TSV608	114	TCV608	136	DHV608	104	DKV090	3,1	SNV090-F-L
FSV608	DH608	TSV608	114	TCV608	136	DHV608	104	DKV090	3,1	SNV090-F-L
FSV509X107	DH509X107	TSV509X107	101	TCV509X107	123	DHV509X107	91	DKV085	2,8	SNV085-F-L
FSV609X107	DH609X107	TSV609X107	119	TCV609X107	141	DHV609X107	109	DKV100	4,3	SNV100-F-L
FSV509X107	DH509X107	TSV509X107	101	TCV509X107	123	DHV509X107	91	DKV085	2,8	SNV085-F-L
FSV609X107	DH609X107	TSV609X107	119	TCV609X107	141	DHV609X107	109	DKV100	4,3	SNV100-F-L
FSV509X107	DH509X107	TSV509X107	101	TCV509X107	123	DHV509X107	91	DKV085	2,8	SNV085-F-L
FSV509X107	DH509X107	TSV509X107	101	TCV509X107	123	DHV509X107	91	DKV085	2,8	SNV085-F-L
FSV609X107	DH609X107	TSV609X107	119	TCV609X107	141	DHV609X107	109	DKV100	4,3	SNV100-F-L
FSV609X107	DH609X107	TSV609X107	119	TCV609X107	141	DHV609X107	109	DKV100	4,3	SNV100-F-L
FSV509X108	DH509X107	TSV509X108	101	TCV509X108	125	DHV509X108	93	DKV085	2,8	SNV085-F-L
FSV609X108	DH609X107	TSV609X108	119	TCV609X108	143	DHV609X108	111	DKV100	4,3	SNV100-F-L
FSV509X108	DH509X107	TSV509X108	101	TCV509X108	125	DHV509X108	93	DKV085	2,8	SNV085-F-L
FSV609X108	DH609X107	TSV609X108	119	TCV609X108	143	DHV609X108	111	DKV100	4,3	SNV100-F-L
FSV509X108	DH509X107	TSV509X108	101	TCV509X108	125	DHV509X108	93	DKV085	2,8	SNV085-F-L
FSV509X108	DH509X107	TSV509X108	101	TCV509X108	125	DHV509X108	93	DKV085	2,8	SNV085-F-L
FSV609X108	DH609X107	TSV609X108	119	TCV609X108	143	DHV609X108	111	DKV100	4,3	SNV100-F-L
FSV609X108	DH609X107	TSV609X108	119	TCV609X108	143	DHV609X108	111	DKV100	4,3	SNV100-F-L
FSV609	DH609	TSV609	119	TCV609	141	DHV609	109	DKV100	4,3	SNV100-F-L
FSV609	DH609	TSV609	119	TCV609	141	DHV609	109	DKV100	4,3	SNV100-F-L
FSV609	DH609	TSV609	119	TCV609	141	DHV609	109	DKV100	4,3	SNV100-F-L
FSV609	DH609	TSV609	119	TCV609	141	DHV609	109	DKV100	4,3	SNV100-F-L

Plummer block housings

SNV, split
For bearings with tapered bore and adapter sleeve
Inch size shaft

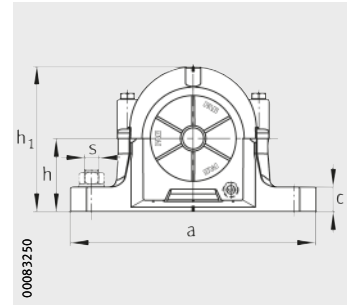
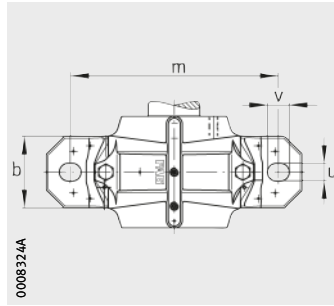

Dimension table (continued) · Dimensions in mm and inch

Shaft		Housing Dimensions											Bearing and accessories				
		h	h ₁	g	b	c	a	m	v	u	s	D	g ₃	Bearing	Adapter sleeve	Locating ring	
inch	mm										mm	inch				Quantity 2	
110/16	41,275	60	117	100	60	25	205	170	20	15	M12	1/2	90	12,5	1210-K	H210X110	FRM90/10,5
110/16	41,275	70	139	110	70	30	255	210	23	18	M16	5/8	110	12,5	1310-K	H310X110	FRM110/10,5
110/16	41,275	60	117	100	60	25	205	170	20	15	M12	1/2	90	12,5	20210-K	H210X110	FRM90/10,5
110/16	41,275	70	139	110	70	30	255	210	23	18	M16	5/8	110	12,5	21310...-K	H310X110	FRM110/10,5
110/16	41,275	60	117	100	60	25	205	170	20	15	M12	1/2	90	12,5	2210-K	H310X110	FRM90/9
110/16	41,275	60	117	100	60	25	205	170	20	15	M12	1/2	90	12,5	22210...-K	H310X110	FRM90/9
110/16	41,275	70	139	110	70	30	255	210	23	18	M16	5/8	110	12,5	22310...-K	H2310X110	FRM110/4
110/16	41,275	70	139	110	70	30	255	210	23	18	M16	5/8	110	12,5	2310-K	H2310X110	FRM110/4
111/16	42,863	60	117	100	60	25	205	170	20	15	M12	1/2	90	12,5	1210-K	H210X111	FRM90/10,5
111/16	42,863	70	139	110	70	30	255	210	23	18	M16	5/8	110	12,5	1310-K	H310X111	FRM110/10,5
111/16	42,863	60	117	100	60	25	205	170	20	15	M12	1/2	90	12,5	20210-K	H210X111	FRM90/10,5
111/16	42,863	70	139	110	70	30	255	210	23	18	M16	5/8	110	12,5	21310...-K	H310X111	FRM110/10,5
111/16	42,863	60	117	100	60	25	205	170	20	15	M12	1/2	90	12,5	2210-K	H310X111	FRM90/9
111/16	42,863	60	117	100	60	25	205	170	20	15	M12	1/2	90	12,5	22210...-K	H310X111	FRM90/9
111/16	42,863	70	139	110	70	30	255	210	23	18	M16	5/8	110	12,5	22310...-K	H2310X111	FRM110/4
111/16	42,863	70	139	110	70	30	255	210	23	18	M16	5/8	110	12,5	2310-K	H2310X111	FRM110/4
112/16	44,45	60	117	100	60	25	205	170	20	15	M12	1/2	90	12,5	1210-K	H210X112	FRM90/10,5
112/16	44,45	70	139	110	70	30	255	210	23	18	M16	5/8	110	12,5	1310-K	H310X112	FRM110/10,5
112/16	44,45	60	117	100	60	25	205	170	20	15	M12	1/2	90	12,5	20210-K	H210X112	FRM90/10,5
112/16	44,45	70	139	110	70	30	255	210	23	18	M16	5/8	110	12,5	21310...-K	H310X112	FRM110/10,5
112/16	44,45	60	117	100	60	25	205	170	20	15	M12	1/2	90	12,5	2210-K	H310X112	FRM90/9
112/16	44,45	60	117	100	60	25	205	170	20	15	M12	1/2	90	12,5	22210...-K	H310X112	FRM90/9
112/16	44,45	70	139	110	70	30	255	210	23	18	M16	5/8	110	12,5	22310...-K	H2310X112	FRM110/4
112/16	44,45	70	139	110	70	30	255	210	23	18	M16	5/8	110	12,5	2310-K	H2310X112	FRM110/4
114/16	47,625	70	133	105	70	28	255	210	23	18	M16	5/8	100	12,5	1211-K	H211X114	FRM100/11,5
114/16	47,625	80	155	115	80	30	275	230	23	18	M16	5/8	120	12,5	1311-K	H311X114	FRM120/11
114/16	47,625	70	133	105	70	28	255	210	23	18	M16	5/8	100	12,5	20211-K	H211X114	FRM100/11,5
114/16	47,625	80	155	115	80	30	275	230	23	18	M16	5/8	120	12,5	20311-K	H311X114	FRM120/11
114/16	47,625	80	155	115	80	30	275	230	23	18	M16	5/8	120	12,5	21311...-K	H311X114	FRM120/11
114/16	47,625	70	133	105	70	28	255	210	23	18	M16	5/8	100	12,5	2211-K	H311X114	FRM100/9,5
114/16	47,625	70	133	105	70	28	255	210	23	18	M16	5/8	100	12,5	22211...-K	H311X114	FRM100/9,5
114/16	47,625	80	155	115	80	30	275	230	23	18	M16	5/8	120	12,5	22311...-K	H2311X114	FRM120/4
114/16	47,625	80	155	115	80	30	275	230	23	18	M16	5/8	120	12,5	2311-K	H2311X114	FRM120/4

① Locating bearing; ② Non-locating bearing

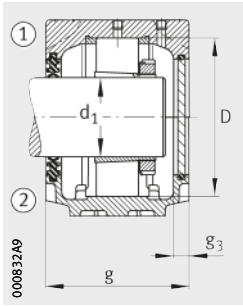

Double lip seal DH
Cover DKVT

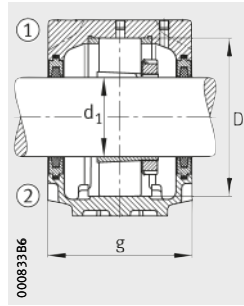

Felt seal FSV

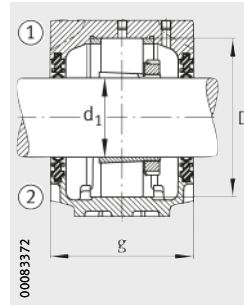

Double lip seal DH

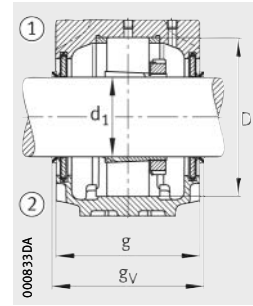

V ring seal DHV



									Housing	
Felt seal	Double lip seal	Labyrinth seal		Taconite seal		V ring seal		Cover	Mass m ≈ kg	Designation
			gL mm		gT mm		gv mm			
FSV510X110	DH510X110	TSV510X110	114	TCV510X110	138	DHV510X110	106	DKV090	3,1	SNV090-F-L
FSV610X110	DH610X110	TSV610X110	124	TCV610X110	148	DHV610X110	116	DKV110	4,9	SNV110-F-L
FSV510X110	DH510X110	TSV510X110	114	TCV510X110	138	DHV510X110	106	DKV090	3,1	SNV090-F-L
FSV610X110	DH610X110	TSV610X110	124	TCV610X110	148	DHV610X110	116	DKV110	4,9	SNV110-F-L
FSV510X110	DH510X110	TSV510X110	114	TCV510X110	138	DHV510X110	106	DKV090	3,1	SNV090-F-L
FSV510X110	DH510X110	TSV510X110	114	TCV510X110	138	DHV510X110	106	DKV090	3,1	SNV090-F-L
FSV610X110	DH610X110	TSV610X110	124	TCV610X110	148	DHV610X110	116	DKV110	4,9	SNV110-F-L
FSV610X110	DH610X110	TSV610X110	124	TCV610X110	148	DHV610X110	116	DKV110	4,9	SNV110-F-L
FSV510X111	DH510X110	TSV510X111	114	TCV510X111	138	DHV510X111	106	DKV090	3,1	SNV090-F-L
FSV610X111	DH610X110	TSV610X111	124	TCV610X111	148	DHV610X111	116	DKV110	4,9	SNV110-F-L
FSV510X111	DH510X110	TSV510X111	114	TCV510X111	138	DHV510X111	106	DKV090	3,1	SNV090-F-L
FSV610X111	DH610X110	TSV610X111	124	TCV610X111	148	DHV610X111	116	DKV110	4,9	SNV110-F-L
FSV510X111	DH510X110	TSV510X111	114	TCV510X111	138	DHV510X111	106	DKV090	3,1	SNV090-F-L
FSV510X111	DH510X110	TSV510X111	114	TCV510X111	138	DHV510X111	106	DKV090	3,1	SNV090-F-L
FSV610X111	DH610X110	TSV610X111	124	TCV610X111	148	DHV610X111	116	DKV110	4,9	SNV110-F-L
FSV610X111	DH610X110	TSV610X111	124	TCV610X111	148	DHV610X111	116	DKV110	4,9	SNV110-F-L
FSV510	DH510	TSV510X112	114	TCV510	138	DHV510	106	DKV090	3,1	SNV090-F-L
FSV610	DH610	TSV610X112	124	TCV610	148	DHV610	116	DKV110	4,9	SNV110-F-L
FSV510	DH510	TSV510X112	114	TCV510	138	DHV510	106	DKV090	3,1	SNV090-F-L
FSV610	DH610	TSV610X112	124	TCV610	148	DHV610	116	DKV110	4,9	SNV110-F-L
FSV510	DH510	TSV510X112	114	TCV510	138	DHV510	106	DKV090	3,1	SNV090-F-L
FSV510	DH510	TSV510X112	114	TCV510	138	DHV510	106	DKV090	3,1	SNV090-F-L
FSV610	DH610	TSV610X112	124	TCV610	148	DHV610	116	DKV110	4,9	SNV110-F-L
FSV610	DH610	TSV610X112	124	TCV610	148	DHV610	116	DKV110	4,9	SNV110-F-L
FSV511X114	DH511X114	TSV511X114	119	TCV511X114	143	DHV511X114	111	DKV100	4,3	SNV100-F-L
FSV611X114	DH611X114	TSV611X114	129	TCV611X114	153	DHV611X114	121	DKV120	6,1	SNV120-F-L
FSV511X114	DH511X114	TSV511X114	119	TCV511X114	143	DHV511X114	111	DKV100	4,3	SNV100-F-L
FSV611X114	DH611X114	TSV611X114	129	TCV611X114	153	DHV611X114	121	DKV120	6,1	SNV120-F-L
FSV511X114	DH511X114	TSV511X114	119	TCV511X114	143	DHV511X114	111	DKV100	4,3	SNV100-F-L
FSV511X114	DH511X114	TSV511X114	119	TCV511X114	143	DHV511X114	111	DKV100	4,3	SNV100-F-L
FSV611X114	DH611X114	TSV611X114	129	TCV611X114	153	DHV611X114	121	DKV120	6,1	SNV120-F-L
FSV611X114	DH611X114	TSV611X114	129	TCV611X114	153	DHV611X114	121	DKV120	6,1	SNV120-F-L
FSV511X114	DH511X114	TSV511X114	119	TCV511X114	143	DHV511X114	111	DKV100	4,3	SNV100-F-L
FSV511X114	DH511X114	TSV511X114	119	TCV511X114	143	DHV511X114	111	DKV100	4,3	SNV100-F-L
FSV611X114	DH611X114	TSV611X114	129	TCV611X114	153	DHV611X114	121	DKV120	6,1	SNV120-F-L
FSV611X114	DH611X114	TSV611X114	129	TCV611X114	153	DHV611X114	121	DKV120	6,1	SNV120-F-L

Plummer block housings

SNV, split
For bearings with tapered bore and adapter sleeve
Inch size shaft

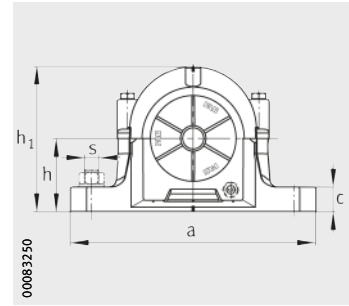
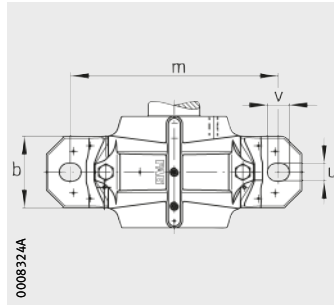

Dimension table (continued) · Dimensions in mm and inch

Shaft		Housing Dimensions											Bearing and accessories				
		h	h ₁	g	b	c	a	m	v	u	s	D	g ₃	Bearing	Adapter sleeve	Locating ring	
inch	mm										mm	inch				Quantity 2	
1 1/16	49,213	70	133	105	70	28	255	210	23	18	M16	5/8	100	12,5	1211-K	H211X115	FRM100/11,5
1 1/16	49,213	80	155	115	80	30	275	230	23	18	M16	5/8	120	12,5	1311-K	H311X115	FRM120/11
1 1/16	49,213	70	133	105	70	28	255	210	23	18	M16	5/8	100	12,5	20211-K	H211X115	FRM100/11,5
1 1/16	49,213	80	155	115	80	30	275	230	23	18	M16	5/8	120	12,5	20311-K	H311X115	FRM120/11
1 1/16	49,213	80	155	115	80	30	275	230	23	18	M16	5/8	120	12,5	21311...-K	H311X115	FRM120/11
1 1/16	49,213	70	133	105	70	28	255	210	23	18	M16	5/8	100	12,5	2211-K	H311X115	FRM100/9,5
1 1/16	49,213	70	133	105	70	28	255	210	23	18	M16	5/8	100	12,5	22211...-K	H311X115	FRM100/9,5
1 1/16	49,213	80	155	115	80	30	275	230	23	18	M16	5/8	120	12,5	22311...-K	H2311X115	FRM120/4
1 1/16	49,213	80	155	115	80	30	275	230	23	18	M16	5/8	120	12,5	2311-K	H2311X115	FRM120/4
2	50,8	70	133	105	70	28	255	210	23	18	M16	5/8	100	12,5	1211-K	H211X200	FRM100/11,5
2	50,8	80	155	115	80	30	275	230	23	18	M16	5/8	120	12,5	1311-K	H311X200	FRM120/11
2	50,8	70	133	105	70	28	255	210	23	18	M16	5/8	100	12,5	20211-K	H211X200	FRM100/11,5
2	50,8	80	155	115	80	30	275	230	23	18	M16	5/8	120	12,5	20311-K	H311X200	FRM120/11
2	50,8	80	155	115	80	30	275	230	23	18	M16	5/8	120	12,5	21311...-K	H311X200	FRM120/11
2	50,8	70	133	105	70	28	255	210	23	18	M16	5/8	100	12,5	2211-K	H311X200	FRM100/9,5
2	50,8	70	133	105	70	28	255	210	23	18	M16	5/8	100	12,5	22211...-K	H311X200	FRM100/9,5
2	50,8	80	155	115	80	30	275	230	23	18	M16	5/8	120	12,5	22311...-K	H2311X200	FRM120/4
2	50,8	80	155	115	80	30	275	230	23	18	M16	5/8	120	12,5	2311-K	H2311X200	FRM120/4
2 2/16	53,975	70	139	110	70	30	255	210	23	18	M16	5/8	110	12,5	1212-K	H212X202	FRM110/13
2 2/16	53,975	80	161	120	80	30	280	230	23	18	M16	5/8	130	12,5	1312-K	H312X202	FRM130/12,5
2 2/16	53,975	70	139	110	70	30	255	210	23	18	M16	5/8	110	12,5	20212-K	H212X202	FRM110/13
2 2/16	53,975	80	161	120	80	30	280	230	23	18	M16	5/8	130	12,5	20312-K	H312X202	FRM130/12,5
2 2/16	53,975	80	161	120	80	30	280	230	23	18	M16	5/8	130	12,5	21312...-K	H312X202	FRM130/12,5
2 2/16	53,975	70	139	110	70	30	255	210	23	18	M16	5/8	110	12,5	2212-K	H312X202	FRM110/10
2 2/16	53,975	70	139	110	70	30	255	210	23	18	M16	5/8	110	12,5	22212...-K	H312X202	FRM110/10
2 2/16	53,975	80	161	120	80	30	280	230	23	18	M16	5/8	130	12,5	22312...-K	H2312X202	FRM130/5
2 2/16	53,975	80	161	120	80	30	280	230	23	18	M16	5/8	130	12,5	2312-K	H2312X202	FRM130/5

① Locating bearing; ② Non-locating bearing

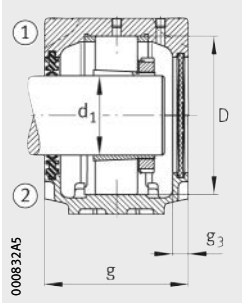

Double lip seal DH
Cover DKV

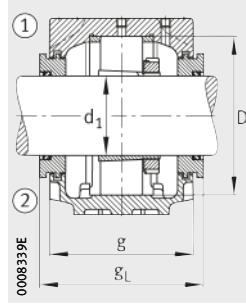

Labyrinth seal TSV

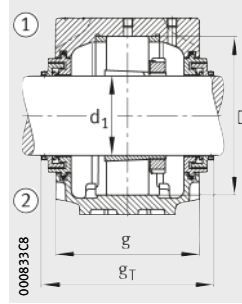

Taconite seal TCV

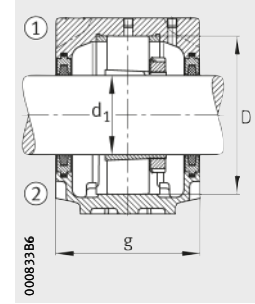

Felt seal FSV



								Housing		
Felt seal	Double lip seal	Labyrinth seal		Taconite seal		V ring seal		Cover	Mass m ≈ kg	Designation
			g _L mm		g _T mm		g _V mm			
FSV511X115	DH511	TSV511X115	119	TCV511X115	143	DHV511X115	111	DKV100	4,3	SNV100-F-L
FSV611X115	DH611	TSV611X115	129	TCV611X115	153	DHV611X115	121	DKV120	6,1	SNV120-F-L
FSV511X115	DH511	TSV511X115	119	TCV511X115	143	DHV511X115	111	DKV100	4,3	SNV100-F-L
FSV611X115	DH611	TSV611X115	129	TCV611X115	153	DHV611X115	121	DKV120	6,1	SNV120-F-L
FSV511X115	DH511	TSV511X115	119	TCV511X115	143	DHV511X115	111	DKV100	4,3	SNV100-F-L
FSV511X115	DH511	TSV511X115	119	TCV511X115	143	DHV511X115	111	DKV100	4,3	SNV100-F-L
FSV611X115	DH611	TSV611X115	129	TCV611X115	153	DHV611X115	121	DKV120	6,1	SNV120-F-L
FSV611X115	DH611	TSV611X115	129	TCV611X115	153	DHV611X115	121	DKV120	6,1	SNV120-F-L
FSV511	DH511	TSV511X200	119	TCV511X200	143	DHV511	111	DKV100	4,3	SNV100-F-L
FSV611	DH611	TSV611X200	129	TCV611X200	153	DHV611	121	DKV120	6,1	SNV120-F-L
FSV511	DH511	TSV511X200	119	TCV511X200	143	DHV511	111	DKV100	4,3	SNV100-F-L
FSV611	DH611	TSV611X200	129	TCV611X200	153	DHV611	121	DKV120	6,1	SNV120-F-L
FSV611	DH611	TSV611X200	129	TCV611X200	153	DHV611	121	DKV120	6,1	SNV120-F-L
FSV511	DH511	TSV511X200	119	TCV511X200	143	DHV511	111	DKV100	4,3	SNV100-F-L
FSV511	DH511	TSV511X200	119	TCV511X200	143	DHV511	111	DKV100	4,3	SNV100-F-L
FSV611	DH611	TSV611X200	129	TCV611X200	153	DHV611	121	DKV120	6,1	SNV120-F-L
FSV611	DH611	TSV611X200	129	TCV611X200	153	DHV611	121	DKV120	6,1	SNV120-F-L
FSV512X202	DH512	TSV512X202	124	TCV512X202	148	DHV512	116	DKV110	4,9	SNV110-F-L
FSV612X202	DH612	TSV612X202	134	TCV612X202	158	DHV612	126	DKV130	6,8	SNV130-F-L
FSV512X202	DH512	TSV512X202	124	TCV512X202	148	DHV512	116	DKV110	4,9	SNV110-F-L
FSV612X202	DH612	TSV612X202	134	TCV612X202	158	DHV612	126	DKV130	6,8	SNV130-F-L
FSV612X202	DH612	TSV612X202	134	TCV612X202	158	DHV612	126	DKV130	6,8	SNV130-F-L
FSV512X202	DH512	TSV512X202	124	TCV512X202	148	DHV512	116	DKV110	4,9	SNV110-F-L
FSV512X202	DH512	TSV512X202	124	TCV512X202	148	DHV512	116	DKV110	4,9	SNV110-F-L
FSV612X202	DH612	TSV612X202	134	TCV612X202	158	DHV612	126	DKV130	6,8	SNV130-F-L
FSV612X202	DH612	TSV612X202	134	TCV612X202	158	DHV612	126	DKV130	6,8	SNV130-F-L

Plummer block housings

SNV, split
For bearings with tapered bore and adapter sleeve
Inch size shaft

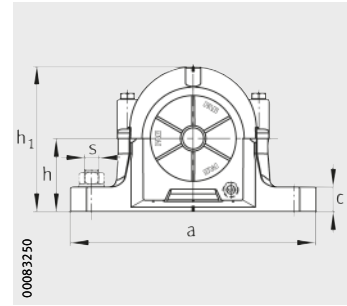
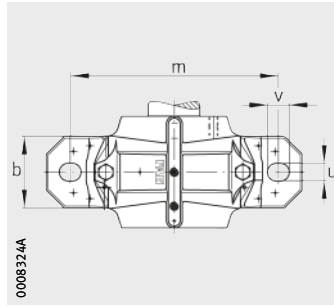

Dimension table (continued) · Dimensions in mm and *inch*

Shaft		Housing Dimensions											Bearing and accessories				
		h	h ₁	g	b	c	a	m	v	u	s	D	g ₃	Bearing	Adapter sleeve	Locating ring	
<i>inch</i>	mm										mm	<i>inch</i>				Quantity 2	
23/16	55,563	80	155	115	80	30	275	230	23	18	M16	5/8	120	12,5	1213-K	H213X203	FRM120/14
23/16	55,563	95	183	135	90	32	315	260	27	22	M20	3/4	140	15	1313-K	H313X203	FRM140/12,5
23/16	55,563	80	155	115	80	30	275	230	23	18	M16	5/8	120	12,5	20213-K	H213X203	FRM120/14
23/16	55,563	95	183	135	90	32	315	260	27	22	M20	3/4	140	15	20313-K	H313X203	FRM140/12,5
23/16	55,563	95	183	135	90	32	315	260	27	22	M20	3/4	140	15	21313..-K	H313X203	FRM140/12,5
23/16	55,563	80	155	115	80	30	275	230	23	18	M16	5/8	120	12,5	2213-K	H313X203	FRM120/10
23/16	55,563	80	155	115	80	30	275	230	23	18	M16	5/8	120	12,5	22213..-K	H313X203	FRM120/10
23/16	55,563	95	183	135	90	32	315	260	27	22	M20	3/4	140	15	22313..-K	H2313X203	FRM140/5
23/16	55,563	95	183	135	90	32	315	260	27	22	M20	3/4	140	15	2313-K	H2313X203	FRM140/5
24/16	57,15	80	155	115	80	30	275	230	23	18	M16	5/8	120	12,5	1213-K	H213X204	FRM120/14
24/16	57,15	95	183	135	90	32	315	260	27	22	M20	3/4	140	15	1313-K	H313X204	FRM140/12,5
24/16	57,15	80	155	115	80	30	275	230	23	18	M16	5/8	120	12,5	20213-K	H213X204	FRM120/14
24/16	57,15	95	183	135	90	32	315	260	27	22	M20	3/4	140	15	20313-K	H313X204	FRM140/12,5
24/16	57,15	95	183	135	90	32	315	260	27	22	M20	3/4	140	15	21313..-K	H313X204	FRM140/12,5
24/16	57,15	80	155	115	80	30	275	230	23	18	M16	5/8	120	12,5	2213-K	H313X204	FRM120/10
24/16	57,15	80	155	115	80	30	275	230	23	18	M16	5/8	120	12,5	22213..-K	H313X204	FRM120/10
24/16	57,15	95	183	135	90	32	315	260	27	22	M20	3/4	140	15	22313..-K	H2313X204	FRM140/5
24/16	57,15	95	183	135	90	32	315	260	27	22	M20	3/4	140	15	2313-K	H2313X204	FRM140/5
26/16	60,325	80	155	115	80	30	275	230	23	18	M16	5/8	120	12,5	1213-K	H213X206	FRM120/14
26/16	60,325	95	183	135	90	32	315	260	27	22	M20	3/4	140	15	1313-K	H313X206	FRM140/12,5
26/16	60,325	80	155	115	80	30	275	230	23	18	M16	5/8	120	12,5	20213-K	H213X206	FRM120/14
26/16	60,325	95	183	135	90	32	315	260	27	22	M20	3/4	140	15	20313-K	H313X206	FRM140/12,5
26/16	60,325	95	183	135	90	32	315	260	27	22	M20	3/4	140	15	21313..-K	H313X206	FRM140/12,5
26/16	60,325	80	155	115	80	30	275	230	23	18	M16	5/8	120	12,5	2213-K	H313X206	FRM120/10
26/16	60,325	80	155	115	80	30	275	230	23	18	M16	5/8	120	12,5	22213..-K	H313X206	FRM120/10
26/16	60,325	95	183	135	90	32	315	260	27	22	M20	3/4	140	15	22313..-K	H2313X206	FRM140/5
26/16	60,325	95	183	135	90	32	315	260	27	22	M20	3/4	140	15	2313-K	H2313X206	FRM140/5

① Locating bearing; ② Non-locating bearing

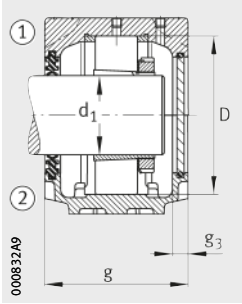

Double lip seal DH
Cover DKVT

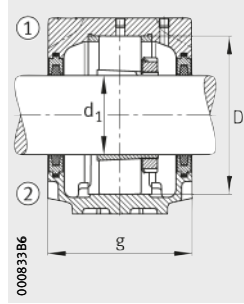

Felt seal FSV

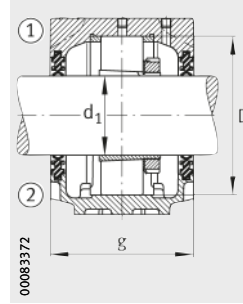

Double lip seal DH

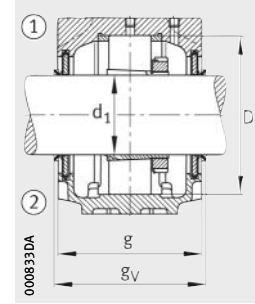

V ring seal DHV



									Housing	
Felt seal	Double lip seal	Labyrinth seal		Taconite seal		V ring seal		Cover	Mass m ≈ kg	Designation
			g _L mm		g _r mm		g _v mm			
FSV513X203	DH513X203	TSV513X203	129	TCV513X203	153	DHV513X203	121	DKV120	6,1	SNV120-F-L
FSV613X203	DH613X203	TSV613X203	150,3	TCV613X203	172	DHV613X203	139	DKV140	9,3	SNV140-F-L
FSV513X203	DH513X203	TSV513X203	129	TCV513X203	153	DHV513X203	121	DKV120	6,1	SNV120-F-L
FSV613X203	DH613X203	TSV613X203	150,3	TCV613X203	172	DHV613X203	139	DKV140	9,3	SNV140-F-L
FSV613X203	DH613X203	TSV613X203	150,3	TCV613X203	172	DHV613X203	139	DKV140	9,3	SNV140-F-L
FSV513X203	DH513X203	TSV513X203	129	TCV513X203	153	DHV513X203	121	DKV120	6,1	SNV120-F-L
FSV513X203	DH513X203	TSV513X203	129	TCV513X203	153	DHV513X203	121	DKV120	6,1	SNV120-F-L
FSV613X203	DH613X203	TSV613X203	150,3	TCV613X203	172	DHV613X203	139	DKV140	9,3	SNV140-F-L
FSV613X203	DH613X203	TSV613X203	150,3	TCV613X203	172	DHV613X203	139	DKV140	9,3	SNV140-F-L
FSV513X204	DH513X203	TSV513X204	129	TCV513X204	153	DHV513X204	121	DKV120	6,1	SNV120-F-L
FSV613X204	DH613X203	TSV613X204	150,3	TCV613X204	172	DHV613X204	139	DKV140	9,3	SNV140-F-L
FSV513X204	DH513X203	TSV513X204	129	TCV513X204	153	DHV513X204	121	DKV120	6,1	SNV120-F-L
FSV613X204	DH613X203	TSV613X204	150,3	TCV613X204	172	DHV613X204	139	DKV140	9,3	SNV140-F-L
FSV613X204	DH613X203	TSV613X204	150,3	TCV613X204	172	DHV613X204	139	DKV140	9,3	SNV140-F-L
FSV513X204	DH513X203	TSV513X204	129	TCV513X204	153	DHV513X204	121	DKV120	6,1	SNV120-F-L
FSV513X204	DH513X203	TSV513X204	129	TCV513X204	153	DHV513X204	121	DKV120	6,1	SNV120-F-L
FSV613X204	DH613X203	TSV613X204	150,3	TCV613X204	172	DHV613X204	139	DKV140	9,3	SNV140-F-L
FSV613X204	DH613X203	TSV613X204	150,3	TCV613X204	172	DHV613X204	139	DKV140	9,3	SNV140-F-L
FSV513	DH513	TSV513	129	TCV513	153	DHV513	121	DKV120	6,1	SNV120-F-L
FSV613	DH613	TSV613	150,3	TCV613	172	DHV613	139	DKV140	9,3	SNV140-F-L
FSV513	DH513	TSV513	129	TCV513	153	DHV513	121	DKV120	6,1	SNV120-F-L
FSV613	DH613	TSV613	150,3	TCV613	172	DHV613	139	DKV140	9,3	SNV140-F-L
FSV613	DH613	TSV613	150,3	TCV613	172	DHV613	139	DKV140	9,3	SNV140-F-L
FSV513	DH513	TSV513	129	TCV513	153	DHV513	121	DKV120	6,1	SNV120-F-L
FSV513	DH513	TSV513	129	TCV513	153	DHV513	121	DKV120	6,1	SNV120-F-L
FSV613	DH613	TSV613	150,3	TCV613	172	DHV613	139	DKV140	9,3	SNV140-F-L
FSV613	DH613	TSV613	150,3	TCV613	172	DHV613	139	DKV140	9,3	SNV140-F-L

Plummer block housings

SNV, split
For bearings with tapered bore and adapter sleeve
Inch size shaft

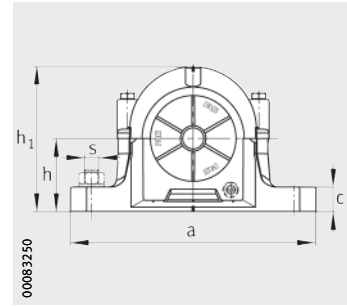
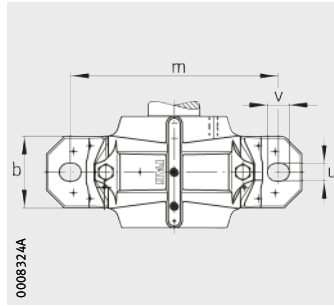

Dimension table (continued) · Dimensions in mm and *inch*

Shaft		Housing Dimensions											Bearing and accessories				
		h	h ₁	g	b	c	a	m	v	u	s		D	g ₃	Bearing	Adapter sleeve	Locating ring
<i>inch</i>	mm										mm	<i>inch</i>					Quantity 2
27/16	61,913	80	161	120	80	30	280	230	23	18	M16	5/8	130	12,5	1215-K	H215X207	FRM130/15,5
27/16	61,913	100	201	145	100	35	345	290	27	22	M20	3/4	160	15	1315-K	H315X207	FRM160/14
27/16	61,913	80	161	120	80	30	280	230	23	18	M16	5/8	130	12,5	20215-K	H215X207	FRM130/15,5
27/16	61,913	100	201	145	100	35	345	290	27	22	M20	3/4	160	15	21315...-K	H315X207	FRM160/14
27/16	61,913	80	161	120	80	30	280	230	23	18	M16	5/8	130	12,5	2215-K	H315X207	FRM130/12,5
27/16	61,913	80	161	120	80	30	280	230	23	18	M16	5/8	130	12,5	22215...-K	H315X207	FRM130/12,5
27/16	61,913	100	201	145	100	35	345	290	27	22	M20	3/4	160	15	22315...-K	H2315X207	FRM160/5
27/16	61,913	100	201	145	100	35	345	290	27	22	M20	3/4	160	15	2315-K	H2315X207	FRM160/5
28/16	63,5	80	161	120	80	30	280	230	23	18	M16	5/8	130	12,5	1215-K	H215X208	FRM130/15,5
28/16	63,5	100	201	145	100	35	345	290	27	22	M20	3/4	160	15	1315-K	H315X208	FRM160/14
28/16	63,5	80	161	120	80	30	280	230	23	18	M16	5/8	130	12,5	20215-K	H215X208	FRM130/15,5
28/16	63,5	100	201	145	100	35	345	290	27	22	M20	3/4	160	15	21315...-K	H315X208	FRM160/14
28/16	63,5	80	161	120	80	30	280	230	23	18	M16	5/8	130	12,5	2215-K	H315X208	FRM130/12,5
28/16	63,5	80	161	120	80	30	280	230	23	18	M16	5/8	130	12,5	22215...-K	H315X208	FRM130/12,5
28/16	63,5	100	201	145	100	35	345	290	27	22	M20	3/4	160	15	22315...-K	H2315X208	FRM160/5
28/16	63,5	100	201	145	100	35	345	290	27	22	M20	3/4	160	15	2315-K	H2315X208	FRM160/5
210/16	66,675	80	161	120	80	30	280	230	23	18	M16	5/8	130	12,5	1215-K	H215X210	FRM130/15,5
210/16	66,675	100	201	145	100	35	345	290	27	22	M20	3/4	160	15	1315-K	H315X210	FRM160/14
210/16	66,675	80	161	120	80	30	280	230	23	18	M16	5/8	130	12,5	20215-K	H215X210	FRM130/15,5
210/16	66,675	100	201	145	100	35	345	290	27	22	M20	3/4	160	15	21315...-K	H315X210	FRM160/14
210/16	66,675	80	161	120	80	30	280	230	23	18	M16	5/8	130	12,5	2215-K	H315X210	FRM130/12,5
210/16	66,675	80	161	120	80	30	280	230	23	18	M16	5/8	130	12,5	22215...-K	H315X210	FRM130/12,5
210/16	66,675	100	201	145	100	35	345	290	27	22	M20	3/4	160	15	22315...-K	H2315X210	FRM160/5
210/16	66,675	100	201	145	100	35	345	290	27	22	M20	3/4	160	15	2315-K	H2315X210	FRM160/5
211/16	68,263	95	183	135	90	32	315	260	27	22	M20	3/4	140	15	1216-K	H216X211	FRM140/16
211/16	68,263	112	219	150	100	35	345	290	27	22	M20	3/4	170	16	1316-K	H316X211	FRM170/14,5
211/16	68,263	95	183	135	90	32	315	260	27	22	M20	3/4	140	15	20216-K	H216X211	FRM140/16
211/16	68,263	112	219	150	100	35	345	290	27	22	M20	3/4	170	16	21316...-K	H316X211	FRM170/14,5
211/16	68,263	95	183	135	90	32	315	260	27	22	M20	3/4	140	15	2216-K	H316X211	FRM140/12,5
211/16	68,263	95	183	135	90	32	315	260	27	22	M20	3/4	140	15	22216...-K	H316X211	FRM140/12,5
211/16	68,263	112	219	150	100	35	345	290	27	22	M20	3/4	170	16	22316...-K	H2316X211	FRM170/5
211/16	68,263	112	219	150	100	35	345	290	27	22	M20	3/4	170	16	2316-K	H2316X211	FRM170/5

① Locating bearing; ② Non-locating bearing

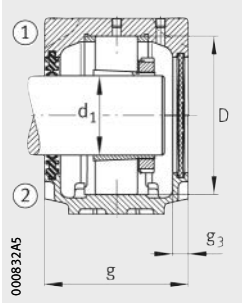

Double lip seal DH
Cover DKV

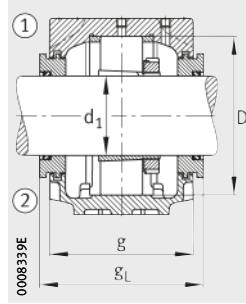

Labyrinth seal TSV

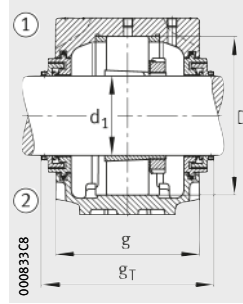

Taconite seal TCV

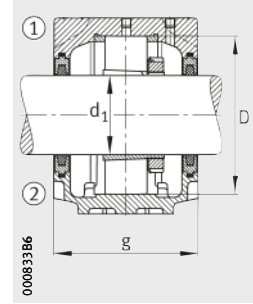

Felt seal FSV



								Housing		
Felt seal	Double lip seal	Labyrinth seal		Taconite seal		V ring seal		Cover	Mass m ≈ kg	Designation
			gL mm		gT mm		gV mm			
FSV515X207	DH515X207	TSV515X207	134	TCV515X207	158	DHV515X207	126	DKV130	6,8	SNV130-F-L
FSV615X207	DH615X207	TSV615X207	160,3	TCV615X207	182	DHV615X207	149	DKV160	12,8	SNV160-F-L
FSV515X207	DH515X207	TSV515X207	134	TCV515X207	158	DHV515X207	126	DKV130	6,8	SNV130-F-L
FSV615X207	DH615X207	TSV615X207	160,3	TCV615X207	182	DHV615X207	149	DKV160	12,8	SNV160-F-L
FSV515X207	DH515X207	TSV515X207	134	TCV515X207	158	DHV515X207	126	DKV130	6,8	SNV130-F-L
FSV515X207	DH515X207	TSV515X207	134	TCV515X207	158	DHV515X207	126	DKV130	6,8	SNV130-F-L
FSV615X207	DH615X207	TSV615X207	160,3	TCV615X207	182	DHV615X207	149	DKV160	12,8	SNV160-F-L
FSV615X207	DH615X207	TSV615X207	160,3	TCV615X207	182	DHV615X207	149	DKV160	12,8	SNV160-F-L
FSV515X208	DH515X207	TSV515X208	134	TCV515X208	158	DHV515X208	126	DKV130	6,8	SNV130-F-L
FSV615X208	DH615X207	TSV615X208	160,3	TCV615X208	182	DHV615X208	149	DKV160	12,8	SNV160-F-L
FSV515X208	DH515X207	TSV515X208	134	TCV515X208	158	DHV515X208	126	DKV130	6,8	SNV130-F-L
FSV615X208	DH615X207	TSV615X208	160,3	TCV615X208	182	DHV615X208	149	DKV160	12,8	SNV160-F-L
FSV515X208	DH515X207	TSV515X208	134	TCV515X208	158	DHV515X208	126	DKV130	6,8	SNV130-F-L
FSV515X208	DH515X207	TSV515X208	134	TCV515X208	158	DHV515X208	126	DKV130	6,8	SNV130-F-L
FSV615X208	DH615X207	TSV615X208	160,3	TCV615X208	182	DHV615X208	149	DKV160	12,8	SNV160-F-L
FSV615X208	DH615X207	TSV615X208	160,3	TCV615X208	182	DHV615X208	149	DKV160	12,8	SNV160-F-L
FSV515X210	DH515	TSV515X210	134	TCV515X210	158	DHV515X210	126	DKV130	6,8	SNV130-F-L
FSV615X210	DH615	TSV615X210	160,3	TCV615X210	182	DHV615X210	149	DKV160	12,8	SNV160-F-L
FSV515X210	DH515	TSV515X210	134	TCV515X210	158	DHV515X210	126	DKV130	6,8	SNV130-F-L
FSV615X210	DH615	TSV615X210	160,3	TCV615X210	182	DHV615X210	149	DKV160	12,8	SNV160-F-L
FSV515X210	DH515	TSV515X210	134	TCV515X210	158	DHV515X210	126	DKV130	6,8	SNV130-F-L
FSV515X210	DH515	TSV515X210	134	TCV515X210	158	DHV515X210	126	DKV130	6,8	SNV130-F-L
FSV615X210	DH615	TSV615X210	160,3	TCV615X210	182	DHV615X210	149	DKV160	12,8	SNV160-F-L
FSV615X210	DH615	TSV615X210	160,3	TCV615X210	182	DHV615X210	149	DKV160	12,8	SNV160-F-L
FSV516X211	DH516X211	TSV516X211	150,3	TCV516X211	176	DHV516X211	143	DKV140	9,3	SNV140-F-L
FSV616X211	DH616X211	TSV616X211	167,3	TCV616X211	193	DHV616X211	158	DKV170	14,4	SNV170-F-L
FSV516X211	DH516X211	TSV516X211	150,3	TCV516X211	176	DHV516X211	143	DKV140	9,3	SNV140-F-L
FSV616X211	DH616X211	TSV616X211	167,3	TCV616X211	193	DHV616X211	158	DKV170	14,4	SNV170-F-L
FSV516X211	DH516X211	TSV516X211	150,3	TCV516X211	176	DHV516X211	143	DKV140	9,3	SNV140-F-L
FSV516X211	DH516X211	TSV516X211	150,3	TCV516X211	176	DHV516X211	143	DKV140	9,3	SNV140-F-L
FSV616X211	DH616X211	TSV616X211	167,3	TCV616X211	193	DHV616X211	158	DKV170	14,4	SNV170-F-L
FSV616X211	DH616X211	TSV616X211	167,3	TCV616X211	193	DHV616X211	158	DKV170	14,4	SNV170-F-L

Plummer block housings

SNV, split
For bearings with tapered bore and adapter sleeve
Inch size shaft

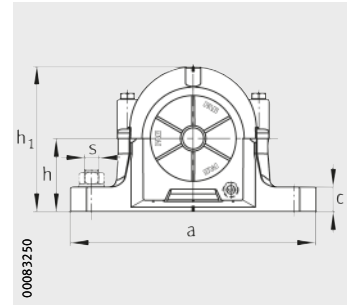
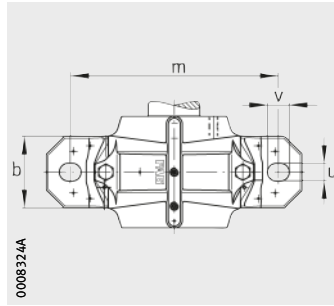

Dimension table (continued) · Dimensions in mm and *inch*

Shaft		Housing Dimensions													Bearing and accessories		
		h	h ₁	g	b	c	a	m	v	u	s		D	g ₃	Bearing	Adapter sleeve	Locating ring
<i>inch</i>	mm										mm	<i>inch</i>					Quantity 2
212/16	69,85	95	183	135	90	32	315	260	27	22	M20	3/4	140	15	1216-K	H216X212	FRM140/16
212/16	69,85	112	219	150	100	35	345	290	27	22	M20	3/4	170	16	1316-K	H316X212	FRM170/14,5
212/16	69,85	95	183	135	90	32	315	260	27	22	M20	3/4	140	15	20216-K	H216X212	FRM140/16
212/16	69,85	112	219	150	100	35	345	290	27	22	M20	3/4	170	16	21316..-K	H316X212	FRM170/14,5
212/16	69,85	95	183	135	90	32	315	260	27	22	M20	3/4	140	15	2216-K	H316X212	FRM140/12,5
212/16	69,85	95	183	135	90	32	315	260	27	22	M20	3/4	140	15	22216..-K	H316X212	FRM140/12,5
212/16	69,85	112	219	150	100	35	345	290	27	22	M20	3/4	170	16	22316..-K	H2316X212	FRM170/5
212/16	69,85	112	219	150	100	35	345	290	27	22	M20	3/4	170	16	2316-K	H2316X212	FRM170/5
214/16	73,025	95	183	135	90	32	315	260	27	22	M20	3/4	140	15	1216-K	H216X214	FRM140/16
214/16	73,025	112	219	150	100	35	345	290	27	22	M20	3/4	170	16	1316-K	H316X214	FRM170/14,5
214/16	73,025	95	183	135	90	32	315	260	27	22	M20	3/4	140	15	20216-K	H216X214	FRM140/16
214/16	73,025	112	219	150	100	35	345	290	27	22	M20	3/4	170	16	21316..-K	H316X214	FRM170/14,5
214/16	73,025	95	183	135	90	32	315	260	27	22	M20	3/4	140	15	2216-K	H316X214	FRM140/12,5
214/16	73,025	95	183	135	90	32	315	260	27	22	M20	3/4	140	15	22216..-K	H316X214	FRM140/12,5
214/16	73,025	112	219	150	100	35	345	290	27	22	M20	3/4	170	16	22316..-K	H2316X214	FRM170/5
214/16	73,025	112	219	150	100	35	345	290	27	22	M20	3/4	170	16	2316-K	H2316X214	FRM170/5
215/16	74,613	95	189	140	90	32	320	260	27	22	M20	3/4	150	15	1217-K	H217X215	FRM150/16,5
215/16	74,613	112	223	160	110	40	380	320	32	26	M24	7/8	180	16	1317-K	H317X215	FRM180/14,5
215/16	74,613	95	189	140	90	32	320	260	27	22	M20	3/4	150	15	20217-K	H217X215	FRM150/16,5
215/16	74,613	112	223	160	110	40	380	320	32	26	M24	7/8	180	16	21317..-K	H317X215	FRM180/14,5
215/16	74,613	95	189	140	90	32	320	260	27	22	M20	3/4	150	15	2217-K	H317X215	FRM150/12,5
215/16	74,613	95	189	140	90	32	320	260	27	22	M20	3/4	150	15	22217..-K	H317X215	FRM150/12,5
215/16	74,613	112	223	160	110	40	380	320	32	26	M24	7/8	180	16	22317..-K	H2317X215	FRM180/5
215/16	74,613	112	223	160	110	40	380	320	32	26	M24	7/8	180	16	2317-K	H2317X215	FRM180/5
3	76,2	95	189	140	90	32	320	260	27	22	M20	3/4	150	15	1217-K	H217X300	FRM150/16,5
3	76,2	112	223	160	110	40	380	320	32	26	M24	7/8	180	16	1317-K	H317X300	FRM180/14,5
3	76,2	95	189	140	90	32	320	260	27	22	M20	3/4	150	15	20217-K	H217X300	FRM150/16,5
3	76,2	112	223	160	110	40	380	320	32	26	M24	7/8	180	16	21317..-K	H317X300	FRM180/14,5
3	76,2	95	189	140	90	32	320	260	27	22	M20	3/4	150	15	2217-K	H317X300	FRM150/12,5
3	76,2	95	189	140	90	32	320	260	27	22	M20	3/4	150	15	22217..-K	H317X300	FRM150/12,5
3	76,2	112	223	160	110	40	380	320	32	26	M24	7/8	180	16	22317..-K	H2317X300	FRM180/5
3	76,2	112	223	160	110	40	380	320	32	26	M24	7/8	180	16	2317-K	H2317X300	FRM180/5

① Locating bearing; ② Non-locating bearing

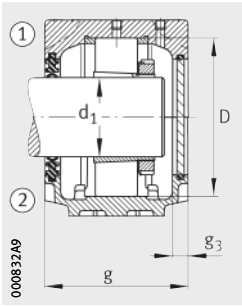

Double lip seal DH
Cover DKVT

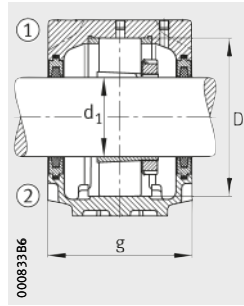

Felt seal FSV

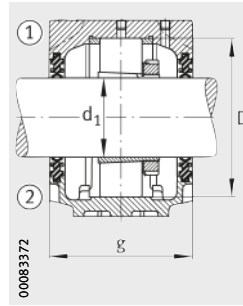

Double lip seal DH

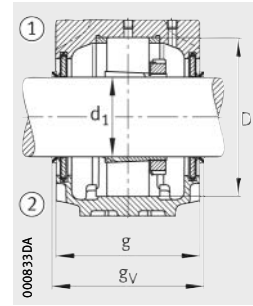

V ring seal DHV



								Housing		
Felt seal	Double lip seal	Labyrinth seal	Taconite seal		V ring seal		Cover	Mass m ≈ kg	Designation	
			gL mm	gT mm	gV mm					
FSV516	DH516	TSV516	150,3	TCV516	176	DHV516	143	DKV140	9,3	SNV140-F-L
FSV616	DH616	TSV616	167,3	TCV616	193	DHV616	158	DKV170	14,4	SNV170-F-L
FSV516	DH516	TSV516	150,3	TCV516	176	DHV516	143	DKV140	9,3	SNV140-F-L
FSV616	DH616	TSV616	167,3	TCV616	193	DHV616	158	DKV170	14,4	SNV170-F-L
FSV516	DH516	TSV516	150,3	TCV516	176	DHV516	143	DKV140	9,3	SNV140-F-L
FSV516	DH516	TSV516	150,3	TCV516	176	DHV516	143	DKV140	9,3	SNV140-F-L
FSV616	DH616	TSV616	167,3	TCV616	193	DHV616	158	DKV170	14,4	SNV170-F-L
FSV616	DH616	TSV616	167,3	TCV616	193	DHV616	158	DKV170	14,4	SNV170-F-L
FSV516X214	DH516X214	TSV516X214	150,3	TCV516X214	176	DHV516X214	143	DKV140	9,3	SNV140-F-L
FSV616X214	DH616X214	TSV616X214	167,3	TCV616X214	193	DHV616X214	158	DKV170	14,4	SNV170-F-L
FSV516X214	DH516X214	TSV516X214	150,3	TCV516X214	176	DHV516X214	143	DKV140	9,3	SNV140-F-L
FSV616X214	DH616X214	TSV616X214	167,3	TCV616X214	193	DHV616X214	158	DKV170	14,4	SNV170-F-L
FSV516X214	DH516X214	TSV516X214	150,3	TCV516X214	176	DHV516X214	143	DKV140	9,3	SNV140-F-L
FSV516X214	DH516X214	TSV516X214	150,3	TCV516X214	176	DHV516X214	143	DKV140	9,3	SNV140-F-L
FSV616X214	DH616X214	TSV616X214	167,3	TCV616X214	193	DHV616X214	158	DKV170	14,4	SNV170-F-L
FSV616X214	DH616X214	TSV616X214	167,3	TCV616X214	193	DHV616X214	158	DKV170	14,4	SNV170-F-L
FSV517	DH517	TSV517	155,3	TCV517	181	DHV517	148	DKV150	9,9	SNV150-F-L
FSV617	DH617	TSV617	177,3	TCV617	203	DHV617	168	DKV180	17	SNV180-F-L
FSV517	DH517	TSV517	155,3	TCV517	181	DHV517	148	DKV150	9,9	SNV150-F-L
FSV617	DH617	TSV617	177,3	TCV617	203	DHV617	168	DKV180	17	SNV180-F-L
FSV517	DH517	TSV517	155,3	TCV517	181	DHV517	148	DKV150	9,9	SNV150-F-L
FSV517	DH517	TSV517	155,3	TCV517	181	DHV517	148	DKV150	9,9	SNV150-F-L
FSV617	DH617	TSV617	177,3	TCV617	203	DHV617	168	DKV180	17	SNV180-F-L
FSV617	DH617	TSV617	177,3	TCV617	203	DHV617	168	DKV180	17	SNV180-F-L
FSV517X300	DH517	TSV517X300	155,3	TCV517X300	181	DHV517X300	148	DKV150	9,9	SNV150-F-L
FSV617X300	DH617	TSV617X300	177,3	TCV617X300	203	DHV617X300	168	DKV180	17	SNV180-F-L
FSV517X300	DH517	TSV517X300	155,3	TCV517X300	181	DHV517X300	148	DKV150	9,9	SNV150-F-L
FSV617X300	DH617	TSV617X300	177,3	TCV617X300	203	DHV617X300	168	DKV180	17	SNV180-F-L
FSV517X300	DH517	TSV517X300	155,3	TCV517X300	181	DHV517X300	148	DKV150	9,9	SNV150-F-L
FSV517X300	DH517	TSV517X300	155,3	TCV517X300	181	DHV517X300	148	DKV150	9,9	SNV150-F-L
FSV617X300	DH617	TSV617X300	177,3	TCV617X300	203	DHV617X300	168	DKV180	17	SNV180-F-L
FSV617X300	DH617	TSV617X300	177,3	TCV617X300	203	DHV617X300	168	DKV180	17	SNV180-F-L

Plummer block housings

SNV, split
For bearings with tapered bore and adapter sleeve
Inch size shaft

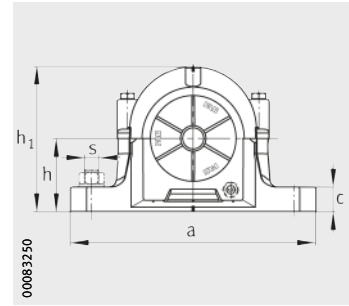
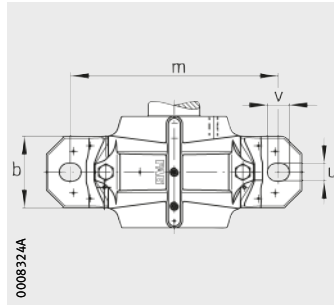

Dimension table (continued) · Dimensions in mm and *inch*

Shaft		Housing Dimensions													Bearing and accessories		
		h	h ₁	g	b	c	a	m	v	u	s		D	g ₃	Bearing	Adapter sleeve	Locating ring
<i>inch</i>	mm										mm	<i>inch</i>					Quantity 2
32/16	79,375	100	201	145	100	35	345	290	27	22	M20	3/4	160	15	1218-K	H218X302	FRM160/17,5
32/16	79,375	112	229	155	110	40	380	320	32	26	M24	7/8	190	15	1318-K	H318X302	FRM190/15,5
32/16	79,375	100	201	145	100	35	345	290	27	22	M20	3/4	160	15	20218-K	H218X302	FRM160/17,5
32/16	79,375	112	229	155	110	40	380	320	32	26	M24	7/8	190	15	20318-K	H318X302	FRM190/15,5
32/16	79,375	112	229	155	110	40	380	320	32	26	M24	7/8	190	15	21318..-K	H318X302	FRM190/15,5
32/16	79,375	100	201	145	100	35	345	290	27	22	M20	3/4	160	15	2218-K	H318X302	FRM160/12,5
32/16	79,375	100	201	145	100	35	345	290	27	22	M20	3/4	160	15	22218..-K	H318X302	FRM160/12,5
32/16	79,375	112	229	155	110	40	380	320	32	26	M24	7/8	190	15	22318..-K	H2318X302	FRM190/5
32/16	79,375	112	229	155	110	40	380	320	32	26	M24	7/8	190	15	2318-K	H2318X302	FRM190/5
32/16	79,375	100	201	145	100	35	345	290	27	22	M20	3/4	160	15	23218..-K	H2318X302	FRM160/6,3
33/16	80,963	100	201	145	100	35	345	290	27	22	M20	3/4	160	15	1218-K	H218X303	FRM160/17,5
33/16	80,963	112	229	155	110	40	380	320	32	26	M24	7/8	190	15	1318-K	H318X303	FRM190/15,5
33/16	80,963	100	201	145	100	35	345	290	27	22	M20	3/4	160	15	20218-K	H218X303	FRM160/17,5
33/16	80,963	112	229	155	110	40	380	320	32	26	M24	7/8	190	15	20318-K	H318X303	FRM190/15,5
33/16	80,963	112	229	155	110	40	380	320	32	26	M24	7/8	190	15	21318..-K	H318X303	FRM190/15,5
33/16	80,963	100	201	145	100	35	345	290	27	22	M20	3/4	160	15	2218-K	H318X303	FRM160/12,5
33/16	80,963	100	201	145	100	35	345	290	27	22	M20	3/4	160	15	22218..-K	H318X303	FRM160/12,5
33/16	80,963	112	229	155	110	40	380	320	32	26	M24	7/8	190	15	22318..-K	H2318X303	FRM190/5
33/16	80,963	112	229	155	110	40	380	320	32	26	M24	7/8	190	15	2318-K	H2318X303	FRM190/5
33/16	80,963	100	201	145	100	35	345	290	27	22	M20	3/4	160	15	23218..-K	H2318X303	FRM160/6,3
34/16	82,55	100	201	145	100	35	345	290	27	22	M20	3/4	160	15	1218-K	H218X304	FRM160/17,5
34/16	82,55	112	229	155	110	40	380	320	32	26	M24	7/8	190	15	1318-K	H318X304	FRM190/15,5
34/16	82,55	100	201	145	100	35	345	290	27	22	M20	3/4	160	15	20218-K	H218X304	FRM160/17,5
34/16	82,55	112	229	155	110	40	380	320	32	26	M24	7/8	190	15	20318-K	H318X304	FRM190/15,5
34/16	82,55	112	229	155	110	40	380	320	32	26	M24	7/8	190	15	21318..-K	H318X304	FRM190/15,5
34/16	82,55	100	201	145	100	35	345	290	27	22	M20	3/4	160	15	2218-K	H318X304	FRM160/12,5
34/16	82,55	100	201	145	100	35	345	290	27	22	M20	3/4	160	15	22218..-K	H318X304	FRM160/12,5
34/16	82,55	112	229	155	110	40	380	320	32	26	M24	7/8	190	15	22318..-K	H2318X304	FRM190/5
34/16	82,55	112	229	155	110	40	380	320	32	26	M24	7/8	190	15	2318-K	H2318X304	FRM190/5
34/16	82,55	100	201	145	100	35	345	290	27	22	M20	3/4	160	15	23218..-K	H2318X304	FRM160/6,3

① Locating bearing; ② Non-locating bearing

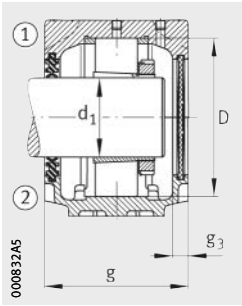

Double lip seal DH
Cover DKV

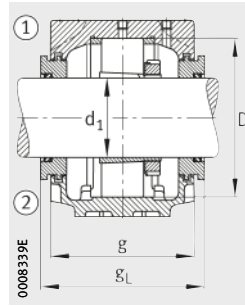

Labyrinth seal TSV

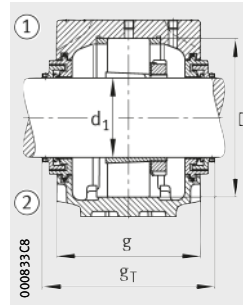

Taconite seal TCV

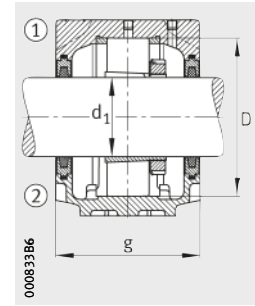

Felt seal FSV



								Housing		
Felt seal	Double lip seal	Labyrinth seal	Taconite seal		V ring seal		Cover	Mass m ≈ kg	Designation	
			g _L mm	g _T mm		g _V mm				
FSV518	DH518	TSV518X302	160,3	TCV518X302	186	DHV518	153	DKV160	12,8	SNV160-F-L
FSV518	DH518	TSV518X302	170,3	TCV518X302	178	DHV518	163	DKV160	22	SNV190-F-L
FSV518	DH518	TSV518X302	160,3	TCV518X302	186	DHV518	153	DKV160	12,8	SNV160-F-L
FSV518	DH518	TSV518X302	170,3	TCV518X302	178	DHV518	163	DKV160	22	SNV190-F-L
FSV518	DH518	TSV518X302	170,3	TCV518X302	178	DHV518	163	DKV160	22	SNV190-F-L
FSV518	DH518	TSV518X302	160,3	TCV518X302	186	DHV518	153	DKV160	12,8	SNV160-F-L
FSV518	DH518	TSV518X302	160,3	TCV518X302	186	DHV518	153	DKV160	12,8	SNV160-F-L
FSV518	DH518	TSV518X302	170,3	TCV518X302	178	DHV518	163	DKV160	22	SNV190-F-L
FSV518	DH518	TSV518X302	170,3	TCV518X302	178	DHV518	163	DKV160	22	SNV190-F-L
FSV518	DH518	TSV518X302	160,3	TCV518X302	186	DHV518	153	DKV160	12,8	SNV160-F-L
FSV518X303	DH518	TSV518X303	160,3	TCV518X303	186	DHV518X303	153	DKV160	12,8	SNV160-F-L
FSV518X303	DH518	TSV518X303	170,3	TCV518X303	178	DHV518X303	163	DKV160	22	SNV190-F-L
FSV518X303	DH518	TSV518X303	160,3	TCV518X303	186	DHV518X303	153	DKV160	12,8	SNV160-F-L
FSV518X303	DH518	TSV518X303	170,3	TCV518X303	178	DHV518X303	163	DKV160	22	SNV190-F-L
FSV518X303	DH518	TSV518X303	170,3	TCV518X303	178	DHV518X303	163	DKV160	22	SNV190-F-L
FSV518X303	DH518	TSV518X303	160,3	TCV518X303	186	DHV518X303	153	DKV160	12,8	SNV160-F-L
FSV518X303	DH518	TSV518X303	160,3	TCV518X303	186	DHV518X303	153	DKV160	12,8	SNV160-F-L
FSV518X303	DH518	TSV518X303	170,3	TCV518X303	178	DHV518X303	163	DKV160	22	SNV190-F-L
FSV518X303	DH518	TSV518X303	170,3	TCV518X303	178	DHV518X303	163	DKV160	22	SNV190-F-L
FSV518X303	DH518	TSV518X303	160,3	TCV518X303	186	DHV518X303	153	DKV160	12,8	SNV160-F-L
FSV518X304	DH518X304	TSV518X304	160,3	TCV518X304	186	DHV518X304	153	DKV160	12,8	SNV160-F-L
FSV518X304	DH518X304	TSV518X304	170,3	TCV518X304	178	DHV518X304	163	DKV160	22	SNV190-F-L
FSV518X304	DH518X304	TSV518X304	160,3	TCV518X304	186	DHV518X304	153	DKV160	12,8	SNV160-F-L
FSV518X304	DH518X304	TSV518X304	170,3	TCV518X304	178	DHV518X304	163	DKV160	22	SNV190-F-L
FSV518X304	DH518X304	TSV518X304	170,3	TCV518X304	178	DHV518X304	163	DKV160	22	SNV190-F-L
FSV518X304	DH518X304	TSV518X304	160,3	TCV518X304	186	DHV518X304	153	DKV160	12,8	SNV160-F-L
FSV518X304	DH518X304	TSV518X304	160,3	TCV518X304	186	DHV518X304	153	DKV160	12,8	SNV160-F-L
FSV518X304	DH518X304	TSV518X304	170,3	TCV518X304	178	DHV518X304	163	DKV160	22	SNV190-F-L
FSV518X304	DH518X304	TSV518X304	170,3	TCV518X304	178	DHV518X304	163	DKV160	22	SNV190-F-L
FSV518X304	DH518X304	TSV518X304	160,3	TCV518X304	186	DHV518X304	153	DKV160	12,8	SNV160-F-L

Plummer block housings

SNV, split
For bearings with tapered bore and adapter sleeve
Inch size shaft

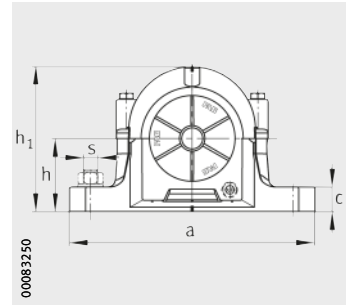
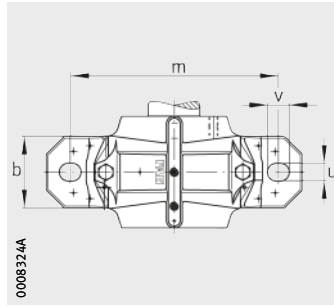

Dimension table (continued) · Dimensions in mm and *inch*

Shaft		Housing Dimensions													Bearing and accessories		
		h	h ₁	g	b	c	a	m	v	u	s		D	g ₃	Bearing	Adapter sleeve	Locating ring
<i>inch</i>	mm										mm	<i>inch</i>					Quantity 2
36/16	85,725	112	219	150	100	35	345	290	27	22	M20	3/4	170	16	1219-K	H219X306	FRM170/18
36/16	85,725	125	248	175	120	45	410	350	32	26	M24	7/8	200	16	1319-K	H319X306	FRM200/17,5
36/16	85,725	125	248	175	120	45	410	350	32	26	M24	7/8	200	16	21319..-K	H319X306	FRM200/17,5
36/16	85,725	112	219	150	100	35	345	290	27	22	M20	3/4	170	16	2219-K	H319X306	FRM170/12,5
36/16	85,725	112	219	150	100	35	345	290	27	22	M20	3/4	170	16	22219..-K	H319X306	FRM170/12,5
36/16	85,725	125	248	175	120	45	410	350	32	26	M24	7/8	200	16	22319..-K	H2319X306	FRM200/6,5
36/16	85,725	125	248	175	120	45	410	350	32	26	M24	7/8	200	16	2319-K	H2319X306	FRM200/6,5
37/16	87,313	112	223	160	110	40	380	320	32	26	M24	7/8	180	16	1220-K	H220X307	FRM180/18
37/16	87,313	140	271	180	120	45	410	350	32	26	M24	7/8	215	16	1320-K	H320X307	FRM215/19,5
37/16	87,313	112	223	160	110	40	380	320	32	26	M24	7/8	180	16	20220-K	H220X307	FRM180/18
37/16	87,313	140	271	180	120	45	410	350	32	26	M24	7/8	215	16	20320-K	H320X307	FRM215/19,5
37/16	87,313	140	271	180	120	45	410	350	32	26	M24	7/8	215	16	21320..-K	H320X307	FRM215/19,5
37/16	87,313	112	223	160	110	40	380	320	32	26	M24	7/8	180	16	2220-K	H320X307	FRM180/12
37/16	87,313	112	223	160	110	40	380	320	32	26	M24	7/8	180	16	22220..-K	H320X307	FRM180/12
37/16	87,313	140	271	180	120	45	410	350	32	26	M24	7/8	215	16	22320..-K	H2320X307	FRM215/6,5
37/16	87,313	140	271	180	120	45	410	350	32	26	M24	7/8	215	16	2320-K	H2320X307	FRM215/6,5
37/16	87,313	112	223	160	110	40	380	320	32	26	M24	7/8	180	16	23220..-K	H2320X307	FRM180/4,85
38/16	88,9	112	223	160	110	40	380	320	32	26	M24	7/8	180	16	1220-K	H220X308	FRM180/18
38/16	88,9	140	271	180	120	45	410	350	32	26	M24	7/8	215	16	1320-K	H320X308	FRM215/19,5
38/16	88,9	112	223	160	110	40	380	320	32	26	M24	7/8	180	16	20220-K	H220X308	FRM180/18
38/16	88,9	140	271	180	120	45	410	350	32	26	M24	7/8	215	16	20320-K	H320X308	FRM215/19,5
38/16	88,9	140	271	180	120	45	410	350	32	26	M24	7/8	215	16	21320..-K	H320X308	FRM215/19,5
38/16	88,9	112	223	160	110	40	380	320	32	26	M24	7/8	180	16	2220-K	H320X308	FRM180/12
38/16	88,9	112	223	160	110	40	380	320	32	26	M24	7/8	180	16	22220..-K	H320X308	FRM180/12
38/16	88,9	140	271	180	120	45	410	350	32	26	M24	7/8	215	16	22320..-K	H2320X308	FRM215/6,5
38/16	88,9	140	271	180	120	45	410	350	32	26	M24	7/8	215	16	2320-K	H2320X308	FRM215/6,5
38/16	88,9	112	223	160	110	40	380	320	32	26	M24	7/8	180	16	23220..-K	H2320X308	FRM180/4,85

① Locating bearing; ② Non-locating bearing

1) Housing with eye bolt.

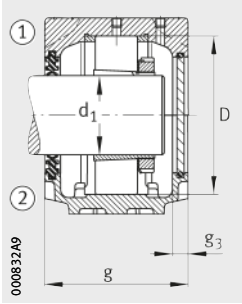

Double lip seal DH
Cover DKVT

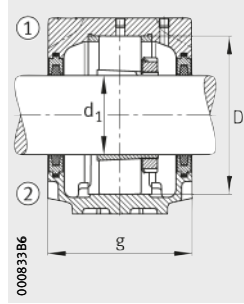

Felt seal FSV

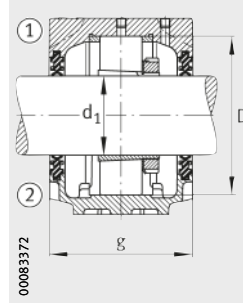

Double lip seal DH

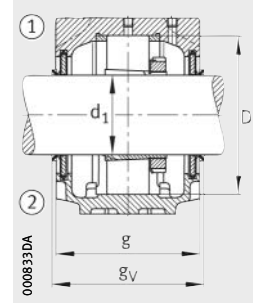

V ring seal DHV



									Housing	
Felt seal	Double lip seal	Labyrinth seal		Taconite seal		V ring seal		Cover	Mass m ≈ kg	Designation
			gL mm		gτ mm		gv mm			
FSV519	DH519	TSV519X306	167,3	TCV519X306	193	DHV519	158	DKV170	14,4	SNV170-F-L
FSV619	DH619	TSV619X306	192,3	TCV619X306	218	DHV619	183	DKV200	21	SNV200-F-L
FSV619	DH619	TSV619X306	192,3	TCV619X306	218	DHV619	183	DKV200	21	SNV200-F-L
FSV519	DH519	TSV519X306	167,3	TCV519X306	193	DHV519	158	DKV170	14,4	SNV170-F-L
FSV519	DH519	TSV519X306	167,3	TCV519X306	193	DHV519	158	DKV170	14,4	SNV170-F-L
FSV619	DH619	TSV619X306	192,3	TCV619X306	218	DHV619	183	DKV200	21	SNV200-F-L
FSV619	DH619	TSV619X306	192,3	TCV619X306	218	DHV619	183	DKV200	21	SNV200-F-L
FSV520X307	DH520X307	TSV520X307	177,3	TCV520X307	203	DHV520X307	168	DKV180	17	SNV180-F-L
FSV620X307	DH620X307	TSV620X307	197,3	TCV620X307	224	DHV620X307	188	DKV215	24,5	SNV215-F-L¹⁾
FSV520X307	DH520X307	TSV520X307	177,3	TCV520X307	203	DHV520X307	168	DKV180	17	SNV180-F-L
FSV620X307	DH620X307	TSV620X307	197,3	TCV620X307	224	DHV620X307	188	DKV215	24,5	SNV215-F-L¹⁾
FSV620X307	DH620X307	TSV620X307	197,3	TCV620X307	224	DHV620X307	188	DKV215	24,5	SNV215-F-L¹⁾
FSV520X307	DH520X307	TSV520X307	177,3	TCV520X307	203	DHV520X307	168	DKV180	17	SNV180-F-L
FSV520X307	DH520X307	TSV520X307	177,3	TCV520X307	203	DHV520X307	168	DKV180	17	SNV180-F-L
FSV620X307	DH620X307	TSV620X307	197,3	TCV620X307	224	DHV620X307	188	DKV215	24,5	SNV215-F-L¹⁾
FSV620X307	DH620X307	TSV620X307	197,3	TCV620X307	224	DHV620X307	188	DKV215	24,5	SNV215-F-L¹⁾
FSV520X307	DH520X307	TSV520X307	177,3	TCV520X307	203	DHV520X307	168	DKV180	17	SNV180-F-L
FSV520X308	DH520X308	TSV520X308	177,3	TCV520X308	203	DHV520X308	168	DKV180	17	SNV180-F-L
FSV620X308	DH620	TSV620X308	197,3	TCV620X308	224	DHV620	188	DKV215	24,5	SNV215-F-L¹⁾
FSV520X308	DH520X308	TSV520X308	177,3	TCV520X308	203	DHV520X308	168	DKV180	17	SNV180-F-L
FSV620X308	DH620	TSV620X308	197,3	TCV620X308	224	DHV620	188	DKV215	24,5	SNV215-F-L¹⁾
FSV620X308	DH620	TSV620X308	197,3	TCV620X308	224	DHV620	188	DKV215	24,5	SNV215-F-L¹⁾
FSV520X308	DH520X308	TSV520X308	177,3	TCV520X308	203	DHV520X308	168	DKV180	17	SNV180-F-L
FSV520X308	DH520X308	TSV520X308	177,3	TCV520X308	203	DHV520X308	168	DKV180	17	SNV180-F-L
FSV620X308	DH620	TSV620X308	197,3	TCV620X308	224	DHV620	188	DKV215	24,5	SNV215-F-L¹⁾
FSV620X308	DH620	TSV620X308	197,3	TCV620X308	224	DHV620	188	DKV215	24,5	SNV215-F-L¹⁾
FSV520X308	DH520X308	TSV520X308	177,3	TCV520X308	203	DHV520X308	168	DKV180	17	SNV180-F-L

Plummer block housings

SNV, split
For bearings with tapered bore and adapter sleeve
Inch size shaft

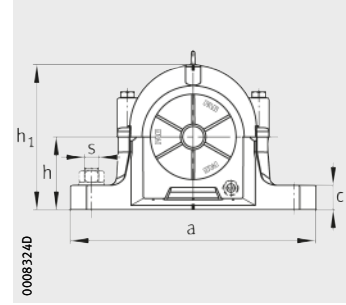
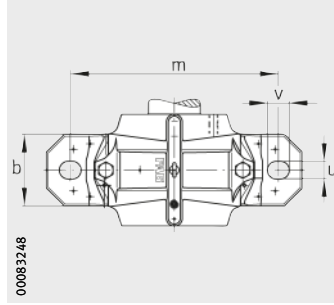

Dimension table (continued) · Dimensions in mm and *inch*

Shaft		Housing Dimensions													Bearing and accessories		
		h	h ₁	g	b	c	a	m	v	u	s		D	g ₃	Bearing	Adapter sleeve	Locating ring
<i>inch</i>	mm										mm	<i>inch</i>					Quantity 2
310/16	92,075	112	223	160	110	40	380	320	32	26	M24	7/8	180	16	1220-K	H220X310	FRM180/18
310/16	92,075	140	271	180	120	45	410	350	32	26	M24	7/8	215	16	1320-K	H320X310	FRM215/19,5
310/16	92,075	112	223	160	110	40	380	320	32	26	M24	7/8	180	16	20220-K	H220X310	FRM180/18
310/16	92,075	140	271	180	120	45	410	350	32	26	M24	7/8	215	16	20320-K	H320X310	FRM215/19,5
310/16	92,075	140	271	180	120	45	410	350	32	26	M24	7/8	215	16	21320...K	H320X310	FRM215/19,5
310/16	92,075	112	223	160	110	40	380	320	32	26	M24	7/8	180	16	2220-K	H320X310	FRM180/12
310/16	92,075	112	223	160	110	40	380	320	32	26	M24	7/8	180	16	22220...K	H320X310	FRM180/12
310/16	92,075	140	271	180	120	45	410	350	32	26	M24	7/8	215	16	22320...K	H2320X310	FRM215/6,5
310/16	92,075	140	271	180	120	45	410	350	32	26	M24	7/8	215	16	2320-K	H2320X310	FRM215/6,5
310/16	92,075	112	223	160	110	40	380	320	32	26	M24	7/8	180	16	23220...K	H2320X310	FRM180/4,85
311/16	93,663	112	223	160	110	40	380	320	32	26	M24	7/8	180	16	1220-K	H220X311	FRM180/18
311/16	93,663	140	271	180	120	45	410	350	32	26	M24	7/8	215	16	1320-K	H320X311	FRM215/19,5
311/16	93,663	112	223	160	110	40	380	320	32	26	M24	7/8	180	16	20220-K	H220X311	FRM180/18
311/16	93,663	140	271	180	120	45	410	350	32	26	M24	7/8	215	16	20320-K	H320X311	FRM215/19,5
311/16	93,663	140	271	180	120	45	410	350	32	26	M24	7/8	215	16	21320...K	H320X311	FRM215/19,5
311/16	93,663	112	223	160	110	40	380	320	32	26	M24	7/8	180	16	2220-K	H320X311	FRM180/12
311/16	93,663	112	223	160	110	40	380	320	32	26	M24	7/8	180	16	22220...K	H320X311	FRM180/12
311/16	93,663	140	271	180	120	45	410	350	32	26	M24	7/8	215	16	22320...K	H2320X311	FRM215/6,5
311/16	93,663	140	271	180	120	45	410	350	32	26	M24	7/8	215	16	2320-K	H2320X311	FRM215/6,5
311/16	93,663	112	223	160	110	40	380	320	32	26	M24	7/8	180	16	23220...K	H2320X311	FRM180/4,85
312/16	95,25	125	248	175	120	45	410	350	32	26	M24	7/8	200	16	1222-K	H222X312	FRM200/21
312/16	95,25	150	298	185	130	50	450	390	35	28	M24	1	240	18	1322-K	H322X312	FRM240/20
312/16	95,25	125	248	175	120	45	410	350	32	26	M24	7/8	200	16	20222-K	H222X312	FRM200/21
312/16	95,25	150	298	185	130	50	450	390	35	28	M24	1	240	18	21322...K	H322X312	FRM240/20
312/16	95,25	125	248	175	120	45	410	350	32	26	M24	7/8	200	16	22222...K	H322X312	FRM200/13,5
312/16	95,25	150	298	185	130	50	450	390	35	28	M24	1	240	18	22322...K	H2322X312	FRM240/5
312/16	95,25	125	248	175	120	45	410	350	32	26	M24	7/8	200	16	23222...K	H2322X312	FRM200/5,1
312/16	95,25	150	298	185	130	50	450	390	35	28	M24	1	240	18	2322-K	H2322X312	FRM240/5

① Locating bearing; ② Non-locating bearing

1) Housing without eye bolt.

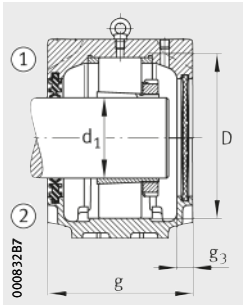

Double lip seal DH
Cover DKV

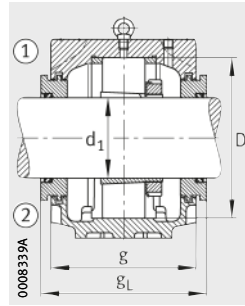

Labyrinth seal TSV

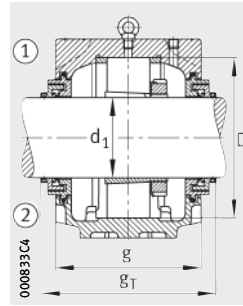

Taconite seal TCV

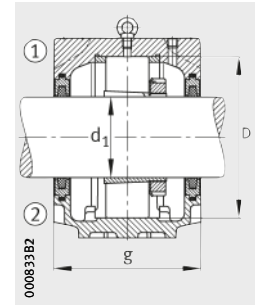

Felt seal FSV



									Housing	
Felt seal	Double lip seal	Labyrinth seal		Taconite seal		V ring seal		Cover	Mass m ≈ kg	Designation
			gL mm		gT mm		gV mm			
FSV520X310	DH520X310	TSV520X310	177,3	TCV520X310	203	DHV520X310	168	DKV180	17	SNV180-F-L¹⁾
FSV620X310	DH620X310	TSV620X310	197,3	TCV620X310	224	DHV620X310	188	DKV215	24,5	SNV215-F-L
FSV520X310	DH520X310	TSV520X310	177,3	TCV520X310	203	DHV520X310	168	DKV180	17	SNV180-F-L¹⁾
FSV620X310	DH620X310	TSV620X310	197,3	TCV620X310	224	DHV620X310	188	DKV215	24,5	SNV215-F-L
FSV620X310	DH620X310	TSV620X310	197,3	TCV620X310	224	DHV620X310	188	DKV215	24,5	SNV215-F-L
FSV520X310	DH520X310	TSV520X310	177,3	TCV520X310	203	DHV520X310	168	DKV180	17	SNV180-F-L¹⁾
FSV520X310	DH520X310	TSV520X310	177,3	TCV520X310	203	DHV520X310	168	DKV180	17	SNV180-F-L¹⁾
FSV620X310	DH620X310	TSV620X310	197,3	TCV620X310	224	DHV620X310	188	DKV215	24,5	SNV215-F-L
FSV620X310	DH620X310	TSV620X310	197,3	TCV620X310	224	DHV620X310	188	DKV215	24,5	SNV215-F-L
FSV520X310	DH520X310	TSV520X310	177,3	TCV520X310	203	DHV520X310	168	DKV180	17	SNV180-F-L¹⁾
FSV520X311	DH520X310	TSV520X311	177,3	TCV520X311	203	DHV520X311	168	DKV180	17	SNV180-F-L¹⁾
FSV620X311	DH620X310	TSV620X311	197,3	TCV620X311	224	DHV620X311	188	DKV215	24,5	SNV215-F-L
FSV520X311	DH520X310	TSV520X311	177,3	TCV520X311	203	DHV520X311	168	DKV180	17	SNV180-F-L¹⁾
FSV620X311	DH620X310	TSV620X311	197,3	TCV620X311	224	DHV620X311	188	DKV215	24,5	SNV215-F-L
FSV620X311	DH620X310	TSV620X311	197,3	TCV620X311	224	DHV620X311	188	DKV215	24,5	SNV215-F-L
FSV520X311	DH520X310	TSV520X311	177,3	TCV520X311	203	DHV520X311	168	DKV180	17	SNV180-F-L¹⁾
FSV520X311	DH520X310	TSV520X311	177,3	TCV520X311	203	DHV520X311	168	DKV180	17	SNV180-F-L¹⁾
FSV620X311	DH620X310	TSV620X311	197,3	TCV620X311	224	DHV620X311	188	DKV215	24,5	SNV215-F-L
FSV620X311	DH620X310	TSV620X311	197,3	TCV620X311	224	DHV620X311	188	DKV215	24,5	SNV215-F-L
FSV520X311	DH520X310	TSV520X311	177,3	TCV520X311	203	DHV520X311	168	DKV180	17	SNV180-F-L¹⁾
FSV522X312	DH522X312	TSV522X312	195,3	TCV522X312	218	DHV522X312	183	DKV200	21	SNV200-F-L¹⁾
FSV522X312	DH522X312	TSV522X312	203,3	TCV522X312	226	DHV522X312	191	DKV200	32	SNV240-F-L
FSV522X312	DH522X312	TSV522X312	195,3	TCV522X312	218	DHV522X312	183	DKV200	21	SNV200-F-L¹⁾
FSV522X312	DH522X312	TSV522X312	203,3	TCV522X312	226	DHV522X312	191	DKV200	32	SNV240-F-L
FSV522X312	DH522X312	TSV522X312	195,3	TCV522X312	218	DHV522X312	183	DKV200	21	SNV200-F-L¹⁾
FSV522X312	DH522X312	TSV522X312	203,3	TCV522X312	226	DHV522X312	191	DKV200	32	SNV240-F-L
FSV522X312	DH522X312	TSV522X312	195,3	TCV522X312	218	DHV522X312	183	DKV200	21	SNV200-F-L¹⁾
FSV522X312	DH522X312	TSV522X312	203,3	TCV522X312	226	DHV522X312	191	DKV200	32	SNV240-F-L

Plummer block housings

SNV, split
For bearings with tapered bore and adapter sleeve
Inch size shaft

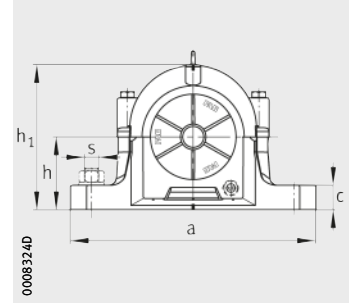
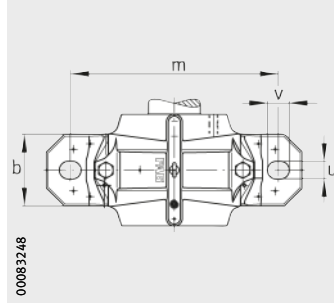

Dimension table (continued) · Dimensions in mm and *inch*

Shaft		Housing Dimensions											Bearing and accessories				
		h	h ₁	g	b	c	a	m	v	u	s	D	g ₃	Bearing	Adapter sleeve	Locating ring	
<i>inch</i>	mm										mm	<i>inch</i>				Quantity 2	
3 1/16	98,425	125	248	175	120	45	410	350	32	26	M24	7/8	200	16	1222-K	H222X314	FRM200/21
3 1/16	98,425	150	298	185	130	50	450	390	35	28	M24	1	240	18	1322-K	H322X314	FRM240/20
3 1/16	98,425	125	248	175	120	45	410	350	32	26	M24	7/8	200	16	20222-K	H222X314	FRM200/21
3 1/16	98,425	150	298	185	130	50	450	390	35	28	M24	1	240	18	21322...-K	H322X314	FRM240/20
3 1/16	98,425	125	248	175	120	45	410	350	32	26	M24	7/8	200	16	22222...-K	H322X314	FRM200/13,5
3 1/16	98,425	125	248	175	120	45	410	350	32	26	M24	7/8	200	16	2222-K	H322X314	FRM200/13,5
3 1/16	98,425	150	298	185	130	50	450	390	35	28	M24	1	240	18	22322...-K	H2322X314	FRM240/5
3 1/16	98,425	125	248	175	120	45	410	350	32	26	M24	7/8	200	16	23222...-K	H2322X314	FRM200/5,1
3 1/16	98,425	150	298	185	130	50	450	390	35	28	M24	1	240	18	2322-K	H2322X314	FRM240/5
3 15/16	100,013	125	248	175	120	45	410	350	32	26	M24	7/8	200	16	1222-K	H222X315	FRM200/21
3 15/16	100,013	150	298	185	130	50	450	390	35	28	M24	1	240	18	1322-K	H322X315	FRM240/20
3 15/16	100,013	125	248	175	120	45	410	350	32	26	M24	7/8	200	16	20222-K	H222X315	FRM200/21
3 15/16	100,013	150	298	185	130	50	450	390	35	28	M24	1	240	18	21322...-K	H322X315	FRM240/20
3 15/16	100,013	125	248	175	120	45	410	350	32	26	M24	7/8	200	16	22222...-K	H322X315	FRM200/13,5
3 15/16	100,013	125	248	175	120	45	410	350	32	26	M24	7/8	200	16	2222-K	H322X315	FRM200/13,5
3 15/16	100,013	150	298	185	130	50	450	390	35	28	M24	1	240	18	22322...-K	H2322X315	FRM240/5
3 15/16	100,013	125	248	175	120	45	410	350	32	26	M24	7/8	200	16	23222...-K	H2322X315	FRM200/5,1
3 15/16	100,013	150	298	185	130	50	450	390	35	28	M24	1	240	18	2322-K	H2322X315	FRM240/5
4	101,6	125	248	175	120	45	410	350	32	26	M24	7/8	200	16	1222-K	H222X400	FRM200/21
4	101,6	150	298	185	130	50	450	390	35	28	M24	1	240	18	1322-K	H322X400	FRM240/20
4	101,6	125	248	175	120	45	410	350	32	26	M24	7/8	200	16	20222-K	H222X400	FRM200/21
4	101,6	150	298	185	130	50	450	390	35	28	M24	1	240	18	21322...-K	H322X400	FRM240/20
4	101,6	125	248	175	120	45	410	350	32	26	M24	7/8	200	16	22222...-K	H322X400	FRM200/13,5
4	101,6	125	248	175	120	45	410	350	32	26	M24	7/8	200	16	2222-K	H322X400	FRM200/13,5
4	101,6	150	298	185	130	50	450	390	35	28	M24	1	240	18	22322...-K	H2322X400	FRM240/5
4	101,6	125	248	175	120	45	410	350	32	26	M24	7/8	200	16	23222...-K	H2322X400	FRM200/5,1
4	101,6	150	298	185	130	50	450	390	35	28	M24	1	240	18	2322-K	H2322X400	FRM240/5
4 3/16	106,363	140	271	180	120	45	410	350	32	26	M24	7/8	215	16	20224-K	H3024X403	FRM215/23
4 3/16	106,363	140	271	180	120	45	410	350	32	26	M24	7/8	215	16	22224...-K	H3124X403	FRM215/14
4 3/16	106,363	160	321	190	160	60	530	450	42	35	M30	1 1/4	260	18	22324...-K	H2324X403	FRM260/5
4 3/16	106,363	140	271	180	120	45	410	350	32	26	M24	7/8	215	16	23224...-K	H2324X403	FRM215/5

① Locating bearing; ② Non-locating bearing

1) Housing without eye bolt.

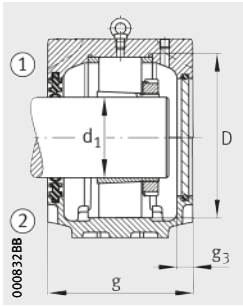

Double lip seal DH
Cover DKVT

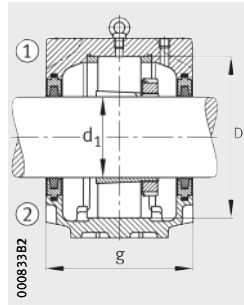

Felt seal FSV

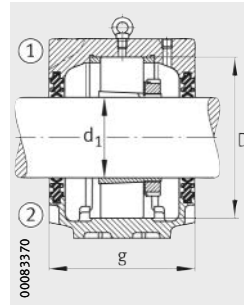

Double lip seal DH

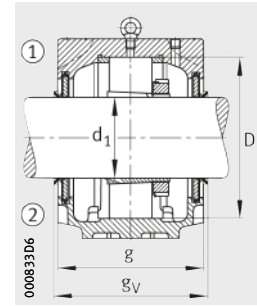

V ring seal DHV



									Housing	
Felt seal	Double lip seal	Labyrinth seal		Taconite seal		V ring seal		Cover	Mass m ≈ kg	Designation
			gL mm		gT mm		gv mm			
FSV522X314	DH522X314	TSV522X314	195,3	TCV522X314	218	DHV522X314	183	DKV200	21	SNV200-F-L ¹⁾
FSV522X314	DH522X314	TSV522X314	203,3	TCV522X314	226	DHV522X314	191	DKV200	32	SNV240-F-L
FSV522X314	DH522X314	TSV522X314	195,3	TCV522X314	218	DHV522X314	183	DKV200	21	SNV200-F-L ¹⁾
FSV522X314	DH522X314	TSV522X314	203,3	TCV522X314	226	DHV522X314	191	DKV200	32	SNV240-F-L
FSV522X314	DH522X314	TSV522X314	195,3	TCV522X314	218	DHV522X314	183	DKV200	21	SNV200-F-L ¹⁾
FSV522X314	DH522X314	TSV522X314	195,3	TCV522X314	218	DHV522X314	183	DKV200	21	SNV200-F-L ¹⁾
FSV522X314	DH522X314	TSV522X314	203,3	TCV522X314	226	DHV522X314	191	DKV200	32	SNV240-F-L
FSV522X314	DH522X314	TSV522X314	195,3	TCV522X314	218	DHV522X314	183	DKV200	21	SNV200-F-L ¹⁾
FSV522X314	DH522X314	TSV522X314	203,3	TCV522X314	226	DHV522X314	191	DKV200	32	SNV240-F-L
FSV522	DH522	TSV522	195,3	TCV522	218	DHV522	183	DKV200	21	SNV200-F-L ¹⁾
FSV522	DH522	TSV522	203,3	TCV522	226	DHV522	191	DKV200	32	SNV240-F-L
FSV522	DH522	TSV522	195,3	TCV522	218	DHV522	183	DKV200	21	SNV200-F-L ¹⁾
FSV522	DH522	TSV522	203,3	TCV522	226	DHV522	191	DKV200	32	SNV240-F-L
FSV522	DH522	TSV522	195,3	TCV522	218	DHV522	183	DKV200	21	SNV200-F-L ¹⁾
FSV522	DH522	TSV522	195,3	TCV522	218	DHV522	183	DKV200	21	SNV200-F-L ¹⁾
FSV522	DH522	TSV522	203,3	TCV522	226	DHV522	191	DKV200	32	SNV240-F-L
FSV522	DH522	TSV522	195,3	TCV522	218	DHV522	183	DKV200	21	SNV200-F-L ¹⁾
FSV522	DH522	TSV522	203,3	TCV522	226	DHV522	191	DKV200	32	SNV240-F-L
FSV522X400	DH522	TSV522X400	195,3	TCV522X400	218	DHV522X400	183	DKV200	21	SNV200-F-L ¹⁾
FSV522X400	DH522	TSV522X400	203,3	TCV522X400	226	DHV522X400	191	DKV200	32	SNV240-F-L
FSV522X400	DH522	TSV522X400	195,3	TCV522X400	218	DHV522X400	183	DKV200	21	SNV200-F-L ¹⁾
FSV522X400	DH522	TSV522X400	203,3	TCV522X400	226	DHV522X400	191	DKV200	32	SNV240-F-L
FSV522X400	DH522	TSV522X400	195,3	TCV522X400	218	DHV522X400	183	DKV200	21	SNV200-F-L ¹⁾
FSV522X400	DH522	TSV522X400	195,3	TCV522X400	218	DHV522X400	183	DKV200	21	SNV200-F-L ¹⁾
FSV522X400	DH522	TSV522X400	203,3	TCV522X400	226	DHV522X400	191	DKV200	32	SNV240-F-L
FSV522X400	DH522	TSV522X400	195,3	TCV522X400	218	DHV522X400	183	DKV200	21	SNV200-F-L ¹⁾
FSV522X400	DH522	TSV522X400	203,3	TCV522X400	226	DHV522X400	191	DKV200	32	SNV240-F-L
FSV524X403	DH524X403	TSV524X403	200,3	TCV524X403	227	DHV524X403	191	DKV215	24,5	SNV215-F-L
FSV524X403	DH524X403	TSV524X403	200,3	TCV524X403	227	DHV524X403	191	DKV215	24,5	SNV215-F-L
FSV524X403	DH524X403	TSV524X403	208,3	TCV524X403	235	DHV524X403	199	DKV215	48	SNV260-F-L
FSV524X403	DH524X403	TSV524X403	200,3	TCV524X403	227	DHV524X403	191	DKV215	24,5	SNV215-F-L

Plummer block housings

SNV, split
For bearings with tapered bore and adapter sleeve
Inch size shaft

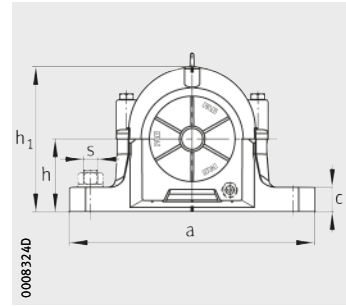
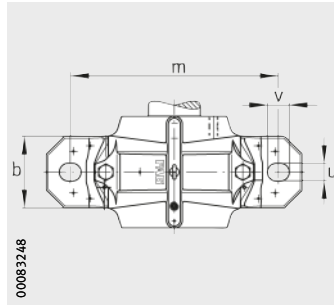

Dimension table (continued) · Dimensions in mm and *inch*

Shaft		Housing Dimensions											Bearing and accessories				
		h	h ₁	g	b	c	a	m	v	u	s	D	g ₃	Bearing	Adapter sleeve	Locating ring	
<i>inch</i>	mm										mm	<i>inch</i>				Quantity 2	
44/16	107,95	140	271	180	120	45	410	350	32	26	M24	7/8	215	16	20224-K	H3024X404	FRM215/23
44/16	107,95	140	271	180	120	45	410	350	32	26	M24	7/8	215	16	22224..-K	H3124X404	FRM215/14
44/16	107,95	160	321	190	160	60	530	450	42	35	M30	1 1/4	260	18	22324..-K	H2324X404	FRM260/5
44/16	107,95	140	271	180	120	45	410	350	32	26	M24	7/8	215	16	23224..-K	H2324X404	FRM215/5
47/16	112,713	150	291	190	130	50	445	380	35	28	M24	1	230	18	20226-K	H3026X407	FRM230/25
47/16	112,713	150	291	190	130	50	445	380	35	28	M24	1	230	18	22226..-K	H3126X407	FRM230/13
47/16	112,713	170	344	205	160	60	550	470	42	35	M30	1 1/4	280	18	22326..-K	H2326X407	FRM280/5
47/16	112,713	150	291	190	130	50	445	380	35	28	M24	1	230	18	23226..-K	H2326X407	FRM230/5
48/16	114,3	150	291	190	130	50	445	380	35	28	M24	1	230	18	20226-K	H3026X408	FRM230/25
48/16	114,3	150	291	190	130	50	445	380	35	28	M24	1	230	18	22226..-K	H3126X408	FRM230/13
48/16	114,3	170	344	205	160	60	550	470	42	35	M30	1 1/4	280	18	22326..-K	H2326X408	FRM280/5
48/16	114,3	150	291	190	130	50	445	380	35	28	M24	1	230	18	23226..-K	H2326X408	FRM230/5
412/16	120,65	150	291	190	130	50	445	380	35	28	M24	1	230	18	20226-K	H3026X412	FRM230/25
412/16	120,65	150	291	190	130	50	445	380	35	28	M24	1	230	18	22226..-K	H3126X412	FRM230/13
412/16	120,65	170	344	205	160	60	550	470	42	35	M30	1 1/4	280	18	22326..-K	H2326X412	FRM280/5
412/16	120,65	150	291	190	130	50	445	380	35	28	M24	1	230	18	23226..-K	H2326X412	FRM230/5
415/16	125,413	150	304	200	150	50	500	420	42	35	M30	1 1/4	250	18	20228-K	H3028X415	FRM250/28
415/16	125,413	150	304	200	150	50	500	420	42	35	M30	1 1/4	250	18	22228..-K	H3128X415	FRM250/15
415/16	125,413	180	366	215	170	65	620	520	42	35	M30	1 1/4	300	18	22328..-K	H2328X415	FRM300/5
415/16	125,413	150	304	200	150	50	500	420	42	35	M30	1 1/4	250	18	23228..-K	H2328X415	FRM250/5
5	127	150	304	200	150	50	500	420	42	35	M30	1 1/4	250	18	20228-K	H3028X500	FRM250/28
5	127	150	304	200	150	50	500	420	42	35	M30	1 1/4	250	18	22228..-K	H3128X500	FRM250/15
5	127	180	366	215	170	65	620	520	42	35	M30	1 1/4	300	18	22328..-K	H2328X500	FRM300/5
5	127	150	304	200	150	50	500	420	42	35	M30	1 1/4	250	18	23228..-K	H2328X500	FRM250/5

① Locating bearing; ② Non-locating bearing

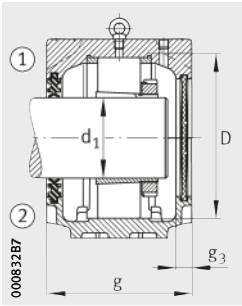

Double lip seal DH
Cover DKV

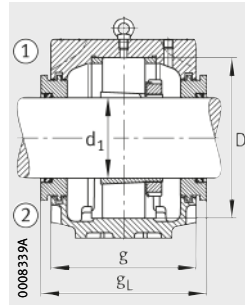

Labyrinth seal TSV

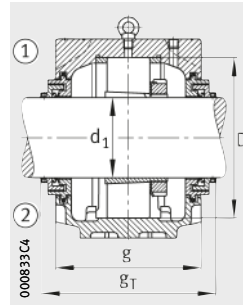

Tacanite seal TCv

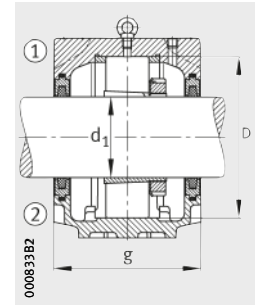

Felt seal FSV



									Housing	
Felt seal	Double lip seal	Labyrinth seal		Tacanite seal		V ring seal		Cover	Mass m ≈ kg	Designation
			gL mm		gT mm		gv mm			
FSV524X404	DH524X403	TSV524X404	200,3	TCV524X404	227	DHV524X404	191	DKV215	24,5	SNV215-F-L
FSV524X404	DH524X403	TSV524X404	200,3	TCV524X404	227	DHV524X404	191	DKV215	24,5	SNV215-F-L
FSV524X404	DH524X403	TSV524X404	208,3	TCV524X404	235	DHV524X404	199	DKV215	48	SNV260-F-L
FSV524X404	DH524X403	TSV524X404	200,3	TCV524X404	227	DHV524X404	191	DKV215	24,5	SNV215-F-L
FSV526X407	DH526X407	TSV526X407	208,3	TCV526X407	235	DHV526X407	199	DKV230	30	SNV230-F-L
FSV526X407	DH526X407	TSV526X407	208,3	TCV526X407	235	DHV526X407	199	DKV230	30	SNV230-F-L
FSV526X407	DH526X407	TSV526X407	223,3	TCV526X407	250	DHV526X407	214	DKV230	55	SNV280-F-L
FSV526X407	DH526X407	TSV526X407	208,3	TCV526X407	235	DHV526X407	199	DKV230	30	SNV230-F-L
FSV526	DH526	TSV526X408	208,3	TCV526	235	DHV526	199	DKV230	30	SNV230-F-L
FSV526	DH526	TSV526X408	208,3	TCV526	235	DHV526	199	DKV230	30	SNV230-F-L
FSV526	DH526	TSV526X408	223,3	TCV526	250	DHV526	214	DKV230	55	SNV280-F-L
FSV526	DH526	TSV526X408	208,3	TCV526	235	DHV526	199	DKV230	30	SNV230-F-L
FSV526X412	DH526X412	TSV526X412	208,3	TCV526X412	235	DHV526X412	199	DKV230	30	SNV230-F-L
FSV526X412	DH526X412	TSV526X412	208,3	TCV526X412	235	DHV526X412	199	DKV230	30	SNV230-F-L
FSV526X412	DH526X412	TSV526X412	223,3	TCV526X412	250	DHV526X412	214	DKV230	55	SNV280-F-L
FSV526X412	DH526X412	TSV526X412	208,3	TCV526X412	235	DHV526X412	199	DKV230	30	SNV230-F-L
FSV528	DH528	TSV528X415	218,3	TCV528X415	245	DHV528	209	DKV250	38	SNV250-F-L
FSV528	DH528	TSV528X415	218,3	TCV528X415	245	DHV528	209	DKV250	38	SNV250-F-L
FSV528	DH528	TSV528X415	233,3	TCV528X415	260	DHV528	224	DKV250	70	SNV300-F-L
FSV528	DH528	TSV528X415	218,3	TCV528X415	245	DHV528	209	DKV250	38	SNV250-F-L
FSV528X500	DH528	TSV528X500	218,3	TCV528X500	245	DHV528X500	209	DKV250	38	SNV250-F-L
FSV528X500	DH528	TSV528X500	218,3	TCV528X500	245	DHV528X500	209	DKV250	38	SNV250-F-L
FSV528X500	DH528	TSV528X500	233,3	TCV528X500	260	DHV528X500	224	DKV250	70	SNV300-F-L
FSV528X500	DH528	TSV528X500	218,3	TCV528X500	245	DHV528X500	209	DKV250	38	SNV250-F-L

Plummer block housings

SNV, split
For bearings with tapered bore and adapter sleeve
Inch size shaft

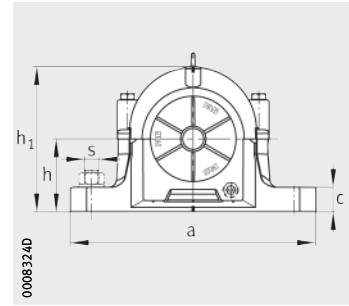
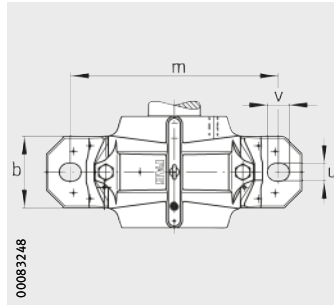

Dimension table (continued) · Dimensions in mm and *inch*

Shaft d ₁		Housing Dimensions											Bearing and accessories				
		h	h ₁	g	b	c	a	m	v	u	s	D	g ₃	Bearing	Adapter sleeve	Locating ring Quantity 2	
<i>inch</i>	mm										mm	<i>inch</i>					
53/16	131,763	160	328	215	160	60	530	450	42	35	M30	1 ¹ / ₄	270	18	20230-K	H3030X503	FRM270/30,5
53/16	131,763	160	328	215	160	60	530	450	42	35	M30	1 ¹ / ₄	270	18	22230..-K	H3130X503	FRM270/16,5
53/16	131,763	190	386	225	180	65	650	560	42	35	M30	1 ¹ / ₄	320	18	22330..-K	H2330X503	FRM320/5
53/16	131,763	160	328	215	160	60	530	450	42	35	M30	1 ¹ / ₄	270	18	23230..-K	H2330X503	FRM270/5
54/16	133,35	160	328	215	160	60	530	450	42	35	M30	1 ¹ / ₄	270	18	20230-K	H3030X504	FRM270/30,5
54/16	133,35	160	328	215	160	60	530	450	42	35	M30	1 ¹ / ₄	270	18	22230..-K	H3130X504	FRM270/16,5
54/16	133,35	190	386	225	180	65	650	560	42	35	M30	1 ¹ / ₄	320	18	22330..-K	H2330X504	FRM320/5
54/16	133,35	160	328	215	160	60	530	450	42	35	M30	1 ¹ / ₄	270	18	23230..-K	H2330X504	FRM270/5
57/16	138,113	170	351	225	160	60	550	470	42	35	M30	1 ¹ / ₄	290	18	20232-K	H3032X507	FRM290/33
57/16	138,113	170	351	225	160	60	550	470	42	35	M30	1 ¹ / ₄	290	18	22232..-K	H3132X507	FRM290/17
57/16	138,113	200	406	235	190	70	680	580	50	42	M36	1 ¹ / ₄	340	18	22332-K	H2332X507	FRM340/5
57/16	138,113	170	351	225	160	60	550	470	42	35	M30	1 ¹ / ₄	290	18	23232..-K	H2332X507	FRM290/5
58/16	139,7	170	351	225	160	60	550	470	42	35	M30	1 ¹ / ₄	290	18	20232-K	H3032X508	FRM290/33
58/16	139,7	170	351	225	160	60	550	470	42	35	M30	1 ¹ / ₄	290	18	22232..-K	H3132X508	FRM290/17
58/16	139,7	200	406	235	190	70	680	580	50	42	M36	1 ¹ / ₄	340	18	22332-K	H2332X508	FRM340/5
58/16	139,7	170	351	225	160	60	550	470	42	35	M30	1 ¹ / ₄	290	18	23232..-K	H2332X508	FRM290/5

① Locating bearing; ② Non-locating bearing

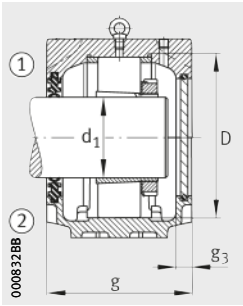

Double lip seal DH
Cover DKVT

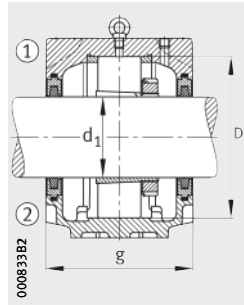

Felt seal FSV

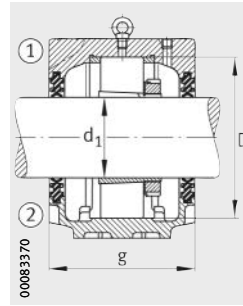

Double lip seal DH

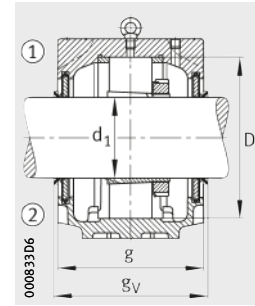

V ring seal DHV



								Housing		
Felt seal	Double lip seal	Labyrinth seal		Taconite seal		V ring seal		Cover	Mass m ≈ kg	Designation
			g _L mm		g _T mm		g _V mm			
FSV530X503	DH530X503	TSV530X503	233,3	TCV530X503	260	DHV530X503	224	DKV270	45,5	SNV270-F-L
FSV530X503	DH530X503	TSV530X503	233,3	TCV530X503	260	DHV530X503	224	DKV270	45,5	SNV270-F-L
FSV530X503	DH530X503	TSV530X503	243,3	TCV530X503	270	DHV530X503	234	DKV270	95	SNV320-F-L
FSV530X503	DH530X503	TSV530X503	233,3	TCV530X503	260	DHV530X503	224	DKV270	45,5	SNV270-F-L
FSV530X504	DH530X504	TSV530X504	233,3	TCV530X504	260	DHV530X504	224	DKV270	45,5	SNV270-F-L
FSV530X504	DH530X504	TSV530X504	233,3	TCV530X504	260	DHV530X504	224	DKV270	45,5	SNV270-F-L
FSV530X504	DH530X504	TSV530X504	243,3	TCV530X504	270	DHV530X504	234	DKV270	95	SNV320-F-L
FSV530X504	DH530X504	TSV530X504	233,3	TCV530X504	260	DHV530X504	224	DKV270	45,5	SNV270-F-L
FSV532X507	DH532X507	TSV532X507	243,3	TCV532X507	270	DHV532X507	234	DKV290	53,8	SNV290-F-L
FSV532X507	DH532X507	TSV532X507	243,3	TCV532X507	270	DHV532X507	234	DKV290	53,8	SNV290-F-L
FSV532X507	DH532X507	TSV532X507	253,3	TCV532X507	298	DHV532X507	244	DKV290	115	SNV340-F-L
FSV532X507	DH532X507	TSV532X507	243,3	TCV532X507	270	DHV532X507	234	DKV290	53,8	SNV290-F-L
FSV532	DH532	TSV532	243,3	TCV532	270	DHV532	234	DKV290	53,8	SNV290-F-L
FSV532	DH532	TSV532	243,3	TCV532	270	DHV532	234	DKV290	53,8	SNV290-F-L
FSV532	DH532	TSV532	253,3	TCV532	298	DHV532	244	DKV290	115	SNV340-F-L
FSV532	DH532	TSV532	243,3	TCV532	270	DHV532	234	DKV290	53,8	SNV290-F-L

FAG



Split plummer block housings S30

Split plummer block housings S30

		Page
Product overview	Split plummer block housings S30.....	132
Features	Suitable bearings	133
	Housing materials and anti-corrosion protection	133
	Locating and non-locating bearings	133
	Seals and covers	134
	Housing configurations.....	134
	Lubrication	136
	Designation structure	137
	Ordering examples	139
Design and safety guidelines	Load carrying capacity	140
	Eye bolts	141
	Foot screws	141
Accuracy	141
Dimension tables	Plummer block housings S30, split, for spherical roller bearings with tapered bore and adapter sleeve.....	142
	Plummer block housings S30, split, for spherical roller bearings with cylindrical bore.....	144



Product overview Split plummer block housings S30

Plummer block housings Split

S30..-N-FZ-AB

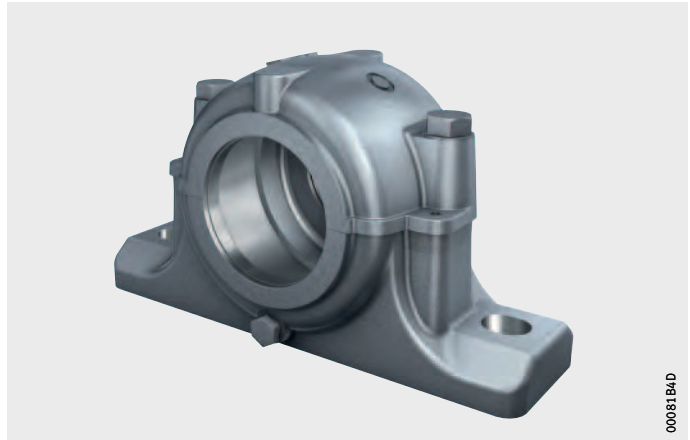

Accessories Covers

DK



Locating rings

FRM



Split plummer block housings S30

Features Split plummer block housings S30 can be used for various applications, such as sintering and pelletising equipment as well as paper processing machinery.



Suitable bearings The dimensions of split plummer block housings S30 are matched to spherical roller bearings 230, see table. The range of shaft diameters is between 110 mm and 150 mm.



Bearing type and sizes

Bearing type	Size
Spherical roller bearings	23024...K to 23034...K
■ with tapered bore and adapter sleeve	
■ with cylindrical bore	23024 to 23034



Split spherical roller bearings Unsplit spherical roller bearings with an adapter sleeve can be replaced by split spherical roller bearings. This gives a considerable reduction in the work associated with bearing replacement in numerous applications.

In order to ensure selection of the correct combination of housing and bearing, please contact us.

Further information ■ WL 43165, Split Spherical Roller Bearings.

Housing materials and anti-corrosion protection

The standard material for the housing bodies is flake graphite cast iron (suffix L). By agreement, housing bodies made from spheroidal graphite cast iron (suffix D) or cast steel (suffix S) are available.

All outer surfaces not machined by chip-forming methods have a universal paint coating (colour RAL 7031, bluish-grey). The coating can be finished using all synthetic resin, polyurethane, acrylic, epoxy resin, chlorinated rubber, nitrocellulose and acid-hardening hammer tone finishes.

Inner and outer surfaces machined by chip-forming methods are provided with anti-corrosion protection that can be easily removed. It is recommended that only volatile solvents and lint-free cloths should be used.

Locating and non-locating bearings

The bearing seats in the housing are machined such that the bearings are movable in the housing and can thus function as non-locating bearings. Locating bearing arrangements can be achieved by the insertion of a locating ring FRM adjacent to the bearing outer ring. Locating rings must be ordered separately.

Split plummer block housings S30

Seals and covers

Plummer block housings S30 are sealed by means of felt seals, *Figure 1*. The felt seals allow shaft misalignment of up to $0,5^\circ$ in both directions and are suitable for grease lubrication.

The oil-soaked felt strips must be inserted in the associated slots in the housing. In the case of a housing closed on one side, 2 felt strips are inserted, while 4 felt strips are necessary in the case of a continuous shaft.

In the case of a housing closed on one side, a cover DK is inserted in the slots instead of the felt strips. Covers DK are made from polyamide. They must be ordered separately.

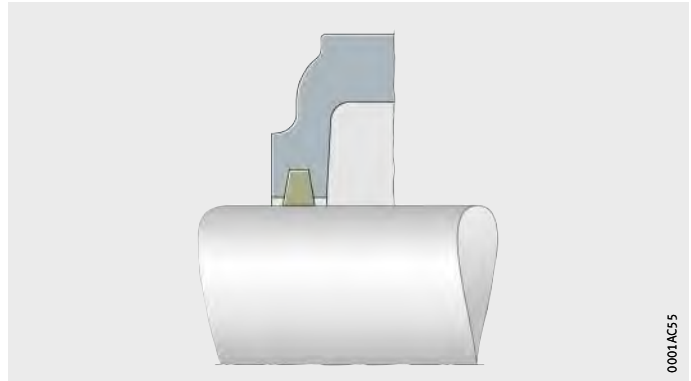

Figure 1
Felt seal
for plummer block housing S30

Housing configurations

The modular structure of plummer block housings S30 facilitates numerous possible combinations, *Figure 2* to *Figure 5*, page 135.

On the basis of the standard components, the following features can be varied in the housing configuration:

- location of bearings with a tapered bore by means of an adapter sleeve on a shaft of constant diameter or of bearings with a cylindrical bore directly on a stepped shaft
- continuous shaft or a housing closed on one side
- design of the bearing arrangement as a locating bearing arrangement or a non-locating bearing arrangement
- spherical roller bearing in a split or unsplit design.

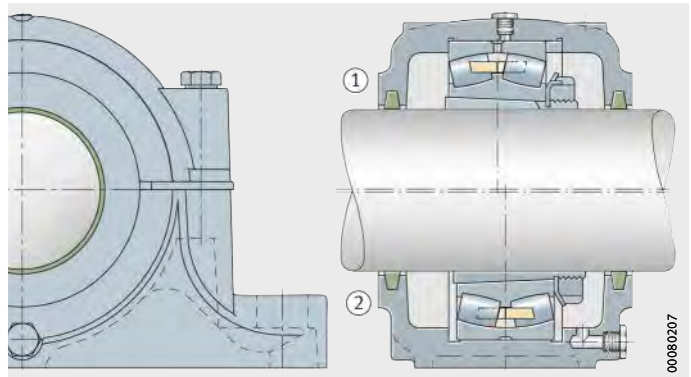

- ① Locating bearing
- ② Non-locating bearing

Figure 2
Plummer block housing S30, split,
for bearings with tapered bore and
adapter sleeve

- ① Locating bearing
- ② Non-locating bearing

Figure 3
Plummer block housing S30
for bearings with tapered bore and
adapter sleeve
(felt seal and cover DK)

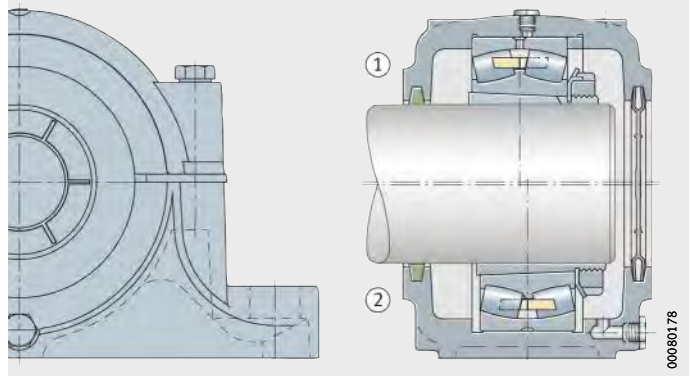

- ① Locating bearing
- ② Non-locating bearing

Figure 4
Plummer block housing S30
for bearings with cylindrical bore
(felt seals on both sides)

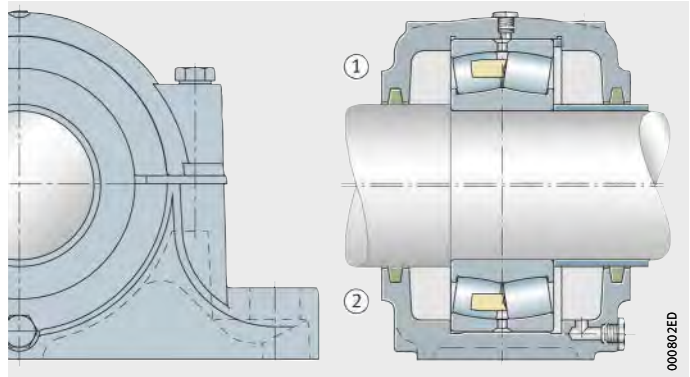

- ① Locating bearing
- ② Non-locating bearing

Figure 5
Plummer block housing S30
for bearings with cylindrical bore
(felt seal and cover DK)

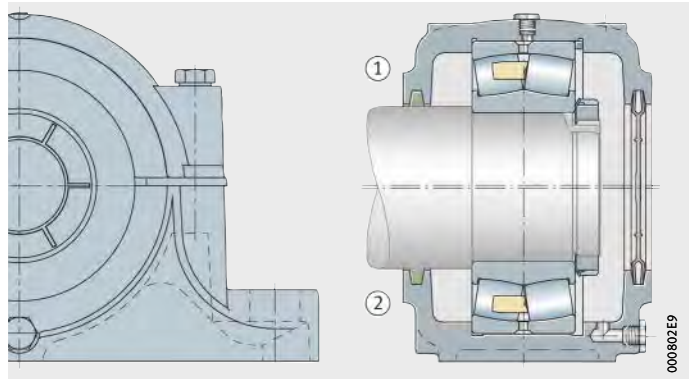

Split plummer block housings S30

Mounting of split spherical roller bearings

In the case of plummer block housings S30, an unsplit spherical roller bearing with a tapered bore and adapter sleeve can be replaced by a split spherical roller bearing, *Figure 6*.

- ① Locating bearing with unsplit bearing
- ② Non-locating bearing with unsplit bearing
- ③ Locating bearing with split bearing
- ④ Non-locating bearing with split bearing

Figure 6
Plummer block housings S30 with split and unsplit spherical roller bearing

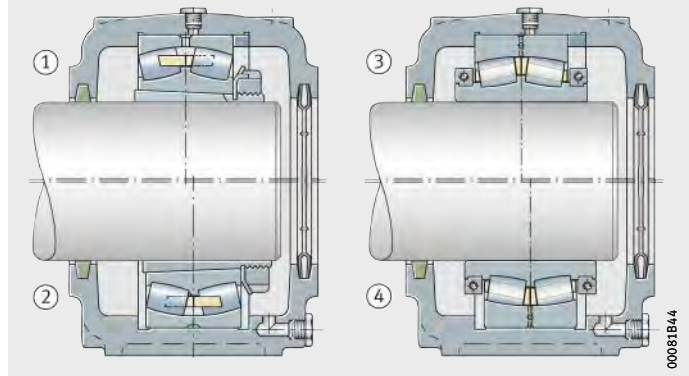

Lubrication

Split plummer block housings S30 are designed for grease lubrication.

Grease quantities

For initial greasing, the basic rule is that the bearing should be filled with grease to 100% and the free volume of the housing to 60%. This is the basis for the recommended grease quantities, see table. The free volume is the space that remains in the housing once the bearing, adapter sleeve, shaft and seals have been fitted.

Recommended grease quantity

Housing	Grease quantity Initial greasing ≈ g
S3024	390
S3026	560
S3028	630
S3030	730
S3032	970
S3034	1 100

Relubrication

The top of the housing has a threaded hole M10×1. In the delivered condition, this is closed off using a plastic stopper. For relubrication, a taper type or button type lubrication nipple can be screwed into place here. In the case of plummer block housings S30, the lubrication nipples are not included in the scope of delivery.

Designation structure

The designation structure for split plummer block housings S30 and accessories is shown in the tables and *Figure 7* to *Figure 9*, page 138.

Designation structure of plummer block housings S30

Feature	Code	Description
① Series	S30	Split plummer block housings S30
② Bore code of bearing	24	Bore diameter (24 · 5) mm = 120 mm
③ Bearing bore	H	Tapered bearing bore and adapter sleeve
	Z	Cylindrical bearing bore
④ Housing design	N	Normal design (without grease valve)
⑤ Type of seal	FZ	Felt seal
⑥ Housing concept	AB	Housing body only, to be supplemented by covers and locating rings
⑦ Housing material	L	Flake graphite cast iron (standard)
	D	Spheroidal graphite cast iron
	S	Cast steel



Figure 7
Designation structure of plummer block housings S30, example

Split plummer block housings S30

Designation structure of covers

Feature	Code	Description
① Series	DK	Cover
② Cover size	127-135	Permissible diameter range for felt locating slot in housing

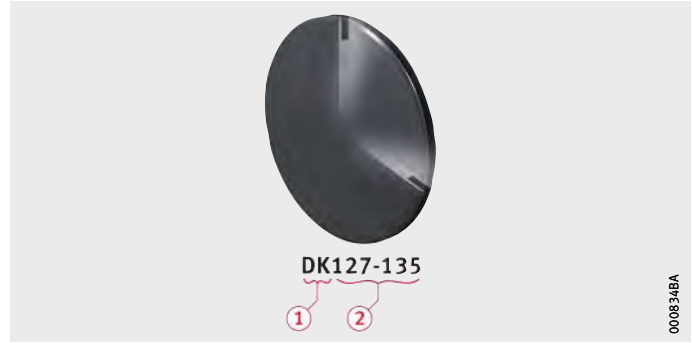

Figure 8
Designation structure of covers, example

Designation structure of locating rings

Feature	Code	Description
① Series	FRM	Locating ring
② Outside diameter	180	Outside diameter 180 mm
③ Width	10	Width 10 mm



Figure 9
Designation structure of locating rings, example

Ordering examples

When a split plummer block housing S30 is ordered, the housing designation only describes the housing body. The other components such as covers or locating rings must be ordered separately in the specific design required. The rolling bearing and, if necessary, the adapter sleeve must also be ordered separately.

Plummer block housings S30 with a bearing fitted give non-locating bearing arrangements. These can be converted into locating bearing arrangements through the additional insertion of locating rings FRM.

The ordering examples show the construction of orders for selected housing combinations and the appropriate bearings. The allocation of housings, bearings and accessories for all housing sizes is shown in the dimension tables.

The felt strips for sealing the housing are included in the scope of delivery and need not be ordered separately.



Example 1 Plummer block housing S30 made from flake graphite cast iron, closed on one side, spherical roller bearing 23024-E1-K-TVPB as non-locating bearing, location by means of adapter sleeve, felt seal.

Order	1 plummer block housing	S3024-H-N-FZ-AB-L
	1 spherical roller bearing	23024-E1-K-TVPB
	1 adapter sleeve	H3024
	1 locating ring	FRM180/10
	1 cover	DK127-135

Example 2 Plummer block housing S30 made from flake graphite cast iron, for continuous shaft, spherical roller bearing 23034-E1-TVPB as non-locating bearing, felt seal.

Order	1 plummer block housing	S3034-Z-N-FZ-AB-L
	1 spherical roller bearing	23034-E1-TVPB

Split plummer block housings S30

Design and safety guidelines Load carrying capacity

Guide values have been determined for the rupture load of plummer block housings S30 and the maximum load carrying capacity of connecting screws for the upper and lower housing sections, *Figure 10* and table, page 141. The guide values are valid for purely static loading.

The guide values for housing rupture load are valid for the standard housing material flake graphite cast iron (suffix L). For spheroidal graphite cast iron (suffix D) a factor of 1,6 should be applied.

The guide values in the table, page 141, are only valid if the flatness of the mounting surface in accordance with DIN EN ISO 1101 corresponds to the tolerance grade IT7 in accordance with DIN EN ISO 286-1 (measured across the diagonal). A precondition for supporting loads is that the housing base surface is completely and rigidly supported.

When determining the permissible static load, safety factors must be applied:

- safety factor of 6 relative to the housing rupture load
- safety factor of 3 relative to the maximum load carrying capacity of the connecting screws.



The housing must not be subjected to an axial load of more than 35% of the housing rupture load F_{180° .

If the housing is subjected to axial load, the permissible axial load of the bearing fitted must be taken into consideration. If the bearing is located on the shaft using an adapter sleeve, the axial retaining force of the bearing and adapter sleeve must also be taken into consideration.

If the load direction is between 55° and 120° or axial load is present, we recommend that the housings should be secured in the load direction by means of stops or dowels.

Figure 10
Load directions F
for the guide values
for the housing rupture load and
the maximum load carrying capacity
of the connecting screws

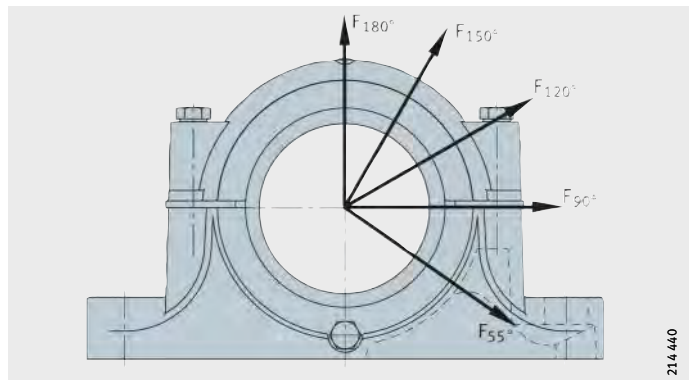

**Guide values
for housing rupture load and
maximum load carrying capacity
of connecting screws**

Housing Designation	Housing rupture load in load direction F Housing made from flake graphite cast iron					Connecting screws			
						Thread to DIN 13	Maximum load carrying capacity of both screws with contact between parting surfaces in load direction		
	55° kN	90° kN	120° kN	150° kN	180° kN		Material 8.8	120° kN	150° kN
S3024	540	320	245	215	270	M20	260	150	130
S3026	620	370	280	250	310	M20	260	150	130
S3028	700	420	315	280	350	M20	260	150	130
S3030	780	470	350	310	390	M20	260	150	130
S3032	860	520	390	345	430	M20	260	150	130
S3034	1 000	600	450	400	500	M24	360	210	180



Housings made from spheroidal graphite cast iron (suffix D) have a housing rupture load 1,6 times higher than that of housings made from flake graphite cast iron.

Eye bolts

In the case of housings S3034, the upper housing section has an eye bolt in accordance with DIN 580. This is intended as a locating point for mounting and dismounting of the housing. The load carrying capacity of the eye bolt allows lifting of the housing including a bearing fitted in the housing.



The eye bolt must always be screwed fully into the housing.

The eye bolt must not be subjected to a mass greater than that of the housing together with the bearing fitted in the housing.

Foot screws

Foot screws are used for screw mounting of the housing to the locating surface. They are not included in the scope of delivery of the housings.

The appropriate screw size for each housing is stated, see dimension tables.

The associated tightening torques are stated for screws with a metric thread in accordance with DIN 13, DIN 962 and DIN ISO 965-2, see table, page 42.

Accuracy

The bearing seat in split plummer block housings S30 is machined to the tolerance class H7.

By agreement, the housings can also be supplied with other tolerance classes for the bearing seat, see section Tolerance class of bearing seat, page 47.

Plummer block housings

S30, split
For spherical roller bearings with tapered bore and adapter sleeve

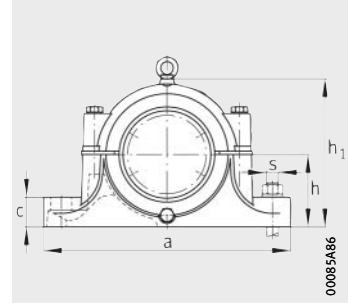
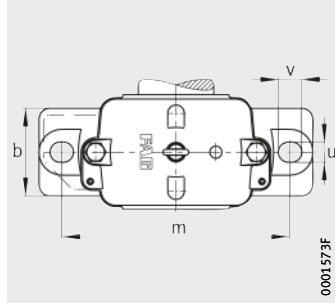

Dimension table - Dimensions in mm

Shaft d_1	Housing Dimensions												
	h	h_1	g	b	c	a	m	v	u	s		D	g_3
											mm	inch	
110	112	215	150	110	40	390	320	36	30	M24	1	180	18
115	125	239	160	120	45	420	350	36	30	M24	1	200	18
125	140	259	170	120	45	420	350	36	30	M24	1	210	21
135	150	278	175	130	45	460	380	36	30	M24	1	225	21
140	150	288	190	130	50	470	390	36	30	M24	1	240	21
150	160	320	200	160	55	540	450	48	36	M30	1 1/8	260	25

① Locating bearing; ② Non-locating bearing

- 1) The felt strips are supplied by the metre and cut to the appropriate length on site.
- 2) Quantity of felt strips required: In the case of a housing closed on one side/in the case of a continuous shaft.
- 3) Housing without eye bolt.

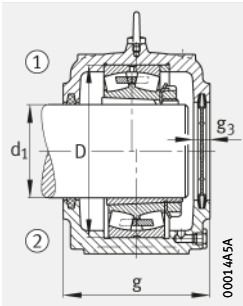

Felt strip
Cover DK

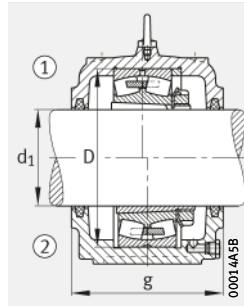

Felt strip



Spherical roller bearing and accessories

Housing

Bearing	Adapter sleeve	Locating ring	Cover	Felt strip ¹⁾ (length 1000 mm)		Mass m ≈ kg	Designation
				Designation	Quantity ²⁾		
23024..-K	H3024	FRM180/10	DK127-135	STRS153401-1-10X8,5-F2	1/1	16,5	S3024-H-N-FZ-AB-L³⁾
23026..-K	H3026	FRM200/10	DK127-135	STRS153401-1-10X8,5-F2	1/1	19,3	S3026-H-N-FZ-AB-L³⁾
23028..-K	H3028	FRM210/10	DK147-155	STRS153401-1-14X11-F2	1/1	24,6	S3028-H-N-FZ-AB-L³⁾
23030..-K	H3030	FRM225/10	DK156-163	STRS153401-1-14X11-F2	1/2	29	S3030-H-N-FZ-AB-L³⁾
23032..-K	H3032(-HG)	FRM240/10	DK166-182	STRS153401-1-14X11-F2	1/2	37	S3032-H-N-FZ-AB-L³⁾
23034..-K	H3034(-HG)	FRM260/10	DK166-182	STRS153401-1-16X12-F2	1/2	45	S3034-H-N-FZ-AB-L

Plummer block housings

S30, split
For spherical roller bearings with cylindrical bore

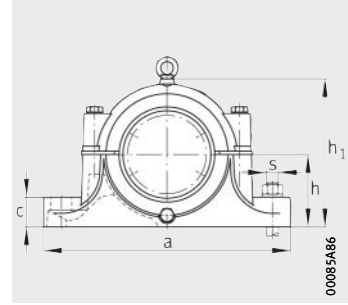
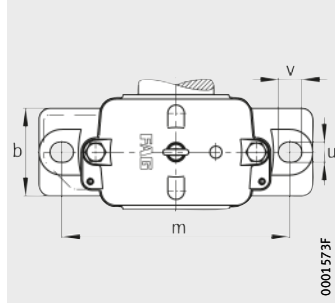

Dimension table - Dimensions in mm

Shaft		Housing Dimensions												
d	d ₂	h	h ₁	g	b	c	a	m	v	u	s		D	g ₃
											mm	inch		
120	130	112	215	150	110	40	390	320	36	30	M24	1	180	18
130	145	125	239	160	120	45	420	350	36	30	M24	1	200	18
140	155	140	259	170	120	45	420	350	36	30	M24	1	210	21
150	160	150	278	175	130	45	460	380	36	30	M24	1	225	21
160	175	150	288	190	130	50	470	390	36	30	M24	1	240	21
170	185	160	320	200	160	55	540	450	48	36	M30	1 1/8	260	25

① Locating bearing; ② Non-locating bearing

- 1) The felt strips are supplied by the metre and cut to the appropriate length on site.
- 2) Quantity of felt strips required: In the case of a housing closed on one side/in the case of a continuous shaft.
- 3) Housing without eye bolt.

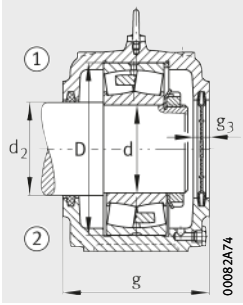

Felt strip
Cover DK

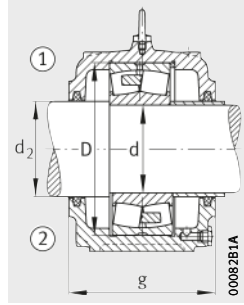

Felt strip



Spherical roller bearing and accessories

Housing

Bearing	Locating ring	Cover	Felt strip ¹⁾ (length 1000 mm)		Mass m ≈ kg	Designation
			Designation	Quantity ²⁾		
23024	FRM180/10	DK147-155	STRS153401-1-10X8,5-F2	1/1	16,5	S3024-Z-N-FZ-AB-L³⁾
23026	FRM200/10	DK156-163	STRS153401-1-10X8,5-F2	1/1	19,3	S3026-Z-N-FZ-AB-L³⁾
23028	FRM210/10	DK166-182	STRS153401-1-14X11-F2	1/1	24,6	S3028-Z-N-FZ-AB-L³⁾
23030	FRM225/10	DK185-197	STRS153401-1-14X11-F2	1/2	29	S3030-Z-N-FZ-AB-L³⁾
23032	FRM240/10	DK200-212	STRS153401-1-14X11-F2	1/2	37	S3032-Z-N-FZ-AB-L³⁾
23034	FRM260/10	DK200-212	STRS153401-1-16X12-F2	1/2	45	S3034-Z-N-FZ-AB-L

FAG



Split plummer block housings SNS

Split plummer block housings SNS

		Page
Product overview	Split plummer block housings SNS	148
Features	Modular concept	150
	Dimensions and interchangeability	150
	Suitable bearings	151
	Housing material and anti-corrosion protection	152
	Locating and non-locating bearings	153
	Longer bearing life	153
	Advantages of the detailed design	154
	Seals and covers	156
	Housing configurations	160
	Lubrication	164
	Designation structure	168
	Ordering examples	172
Design and safety guidelines	Load carrying capacity	173
	Permissible shaft end designs	176
	Eye bolts	177
	Foot screws	177
	Mounting and dismounting	177
Accuracy	177
Dimension tables	Plummer block housings SNS, split, for spherical roller bearings with tapered bore and adapter sleeve, metric shaft.....	178
	Plummer block housings SNS, split, for spherical roller bearings with cylindrical bore, metric shaft.....	188
	Plummer block housings SNS, split, for spherical roller bearings with tapered bore and adapter sleeve, inch size shaft.....	196
	Plummer block housings SNS, split, for spherical roller bearings with tapered bore and adapter sleeve, metric shaft, Bolt-on design.....	212



Product overview Split plummer block housings SNS

Plummer block housings
Split
For labyrinth and Taconite seals

SNS..-H, SNS..-Z



0001AD70

For Bolt-on seals

SNS..-B



0008D681

Accessories
Labyrinth seals
Taconite seals

NTS



NTC



Split labyrinth seals
Bolt-on seals

NTSG



BTAC



Covers

NDK



BDK



Locating rings

NFR



Split plummer block housings SNS

Features Plummer block housings SNS are highly robust housings and ideally suitable for aggressive environmental conditions such as those in mining applications.

Modular concept The housings are designed in accordance with a modular concept. Each housing can be fitted with spherical roller bearings of various diameter and width series if they have the correct outside diameter for the housing.

Depending on their design, the bearings can be located either directly on the shaft or by means of an adapter sleeve. This gives different shaft diameters for the same bearing size. The spacings between the shaft and housing body are compensated by means of appropriately matched seals.

Dimensions and interchangeability

The dimensions of the housings conform to ISO 113.

FAG plummer block housings SNS are a further development of the FAG plummer block housings SD31. The design envelope and mounting dimensions of both series of housings are identical and the housings are interchangeable 1:1.

The interchangeability with other series of FAG housings is as follows:

- All bearing series that can be combined with the FAG plummer block housings SD5 and SD6 can be fitted in plummer block housings SNS.
- Bearing series that can be combined with the FAG plummer block housings S30 can only be fitted in certain cases in plummer block housings SNS.



The dimensions of housings SD5, SD6 and S30 are not identical with the dimensions of housings SNS.

Suitable bearings

Split plummer block housings SNS are suitable for fitting with spherical roller bearings with a tapered or cylindrical bore, see table. The range of shaft diameters is 115 mm to 530 mm and $4\frac{7}{16}$ inch to $19\frac{1}{2}$ inch.

Unsplit spherical roller bearings with an adapter sleeve can be replaced by split spherical roller bearings. This gives a considerable reduction in the work associated with bearing replacement in numerous applications.

In order to ensure selection of the correct combination of housing and bearing when using split bearings, please contact us.



Bearing types and sizes

Bearing type	Size
Spherical roller bearings	22232..-K to 22272..-K
■ with tapered bore and adapter sleeve	22326..-K to 22356..-K
	23036-K to 230/530..-K
	23134..-K to 23196..-K
	23232..-K to 23288..-K
■ with cylindrical bore	22232 to 22272
	22326 to 22356
	23036 to 230/530
	23134 to 23196
	23232 to 23288
	24036 to 240/530
■ split	230SM160 to 230SM410
	230S.607 to 230S.1608
	231SM150 to 231SM410
	231S.515 to 231S.1500
	232SM260 to 232SM340
	232S.1200 to 232S.1308

On the basis of the modular concept, one or more series of plummer block housings SNS are suitable for each series of spherical roller bearings, see tables, page 152.

Split plummer block housings SNS

Plummer block housings SNS for spherical roller bearings with tapered bore and adapter sleeve

Bearing Series	Plummer block housing											
	SNS2264		SNS30		SNS31			SNS32		SNS40		
	Suffix											
	H	Z	H	Z	H	Z	B	H	Z	H	Z	
222..-K	●	-	●	-	●	-	-	-	-	-	-	
223..-K	-	-	●	-	●	-	-	-	-	-	-	
230..-K	-	-	●	-	-	-	-	-	-	-	-	
231..-K	-	-	-	-	●	-	●	-	-	-	-	
232..-K	-	-	●	-	-	-	-	●	-	-	-	

● Suitable

Plummer block housings SNS for spherical roller bearings with cylindrical bore

Bearing Series	Plummer block housing											
	SNS2264		SNS30		SNS31			SNS32		SNS40		
	Suffix											
	H	Z	H	Z	H	Z	B	H	Z	H	Z	
222	-	●	●	-	●	●	-	-	-	-	-	
223	-	-	●	-	●	-	-	-	-	-	-	
230	-	-	●	●	-	-	-	-	-	-	-	
231	-	-	-	-	●	●	-	-	-	-	-	
232	-	-	●	-	-	-	-	-	●	-	-	
240	-	-	●	●	-	-	-	-	-	-	●	

● Suitable

Plummer block housings SNS for split spherical roller bearings

Bearing Series	Plummer block housing											
	SNS2264		SNS30		SNS31			SNS32		SNS40		
	Suffix											
	H	Z	H	Z	H	Z	B	H	Z	H	Z	
230S	-	-	●	-	-	-	-	-	-	-	-	
231S	-	-	-	-	●	-	●	-	-	-	-	
232S	-	-	-	-	-	-	-	●	-	-	-	

● Suitable

Further information

Housing material and anti-corrosion protection

■ WL 43165, Split Spherical Roller Bearings.

The housing bodies are made from spheroidal graphite cast iron GJS-400-15 (suffix D).

All outer surfaces not machined by chip-forming methods and the locating surfaces on the lower housing section have a universal paint coating (colour RAL 7016, anthracite grey). The coating can be finished using all synthetic resin, polyurethane, acrylic, epoxy resin, chlorinated rubber, nitrocellulose and acid-hardening hammer tone finishes.

Inner and outer surfaces machined by chip-forming methods are provided with anti-corrosion protection that can be easily removed. It is recommended that only volatile solvents and lint-free cloths should be used.

Locating and non-locating bearings

The bearing seats in the housing are machined such that the bearings are movable and can thus function as non-locating bearings. Locating bearing arrangements can be achieved by the insertion of locating rings NFR on both sides of the bearing outer ring. Depending on the combination of housing and bearing, either 2, 4 or 6 locating rings will be required, see dimension tables. Locating rings must be ordered separately.



Longer bearing life

In the case of FAG plummer block housings SNS, the life of the spherical roller bearings fitted is up to 50% higher than in the case of conventional plummer block housings. The increase in life is dependent on the application, the load and the bearing design. Calculation of the bearing life is based on the calculation software BEARINX. The reason for the longer bearing life is the optimum load distribution in the bearing that is achieved as a result of the new housing design, *Figure 1*.

Conventional plummer block housings are designed such that the bearing load is introduced into the housing locating face by means of a support area directly below the bearing, *Figure 1*, ②. If loading is in the main load direction, namely with an orientation vertical to the housing locating face, an unfavourable load distribution occurs in the bearing. Due to the narrow load zone, the load is distributed over only a small number of rolling elements, leading to a particularly high load maximum on the roller in the apex position.

In the case of plummer block housings SNS, a material recess below the bearing distributes the support area over two symmetrically arranged support faces, *Figure 1*, ④. This leads to a significant improvement in the load distribution in the bearing. The load zone is wider and the load is distributed more uniformly over several rolling elements. The maximum is now present on the two neighbouring rollers of the roller in the apex position and is reduced. This results in a significant increase in the fatigue life of the rolling bearings.

- ① Conventional plummer block housing with associated load distribution
- ② Support area directly below the bearing
- ③ FAG plummer block housing SNS with associated load distribution
- ④ Material recess below the bearing

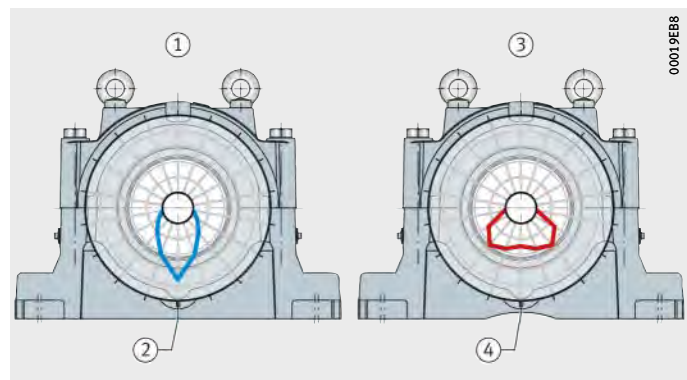

Figure 1
Influence of housing design on the load distribution in the bearing

Split plummer block housings SNS

Advantages of the detailed design

A large number of details in the housing design that are systematically matched to practical application allows a particularly flexible and economical usage of plummer block housings SNS, *Figure 2*.

- ① Lubrication hole with long axial lubrication groove
- ② Pilot hole at predefined position for condition monitoring
- ③ Grease outlet holes
- ④ Indentations indicating shaft and bearing centres
- ⑤ Inclined run-off areas
- ⑥ Machined locating faces
- ⑦ Prepared mounting points for condition monitoring
- ⑧ Marking of housing halves
- ⑨ Dismounting notches
- ⑩ Projection of upper housing section

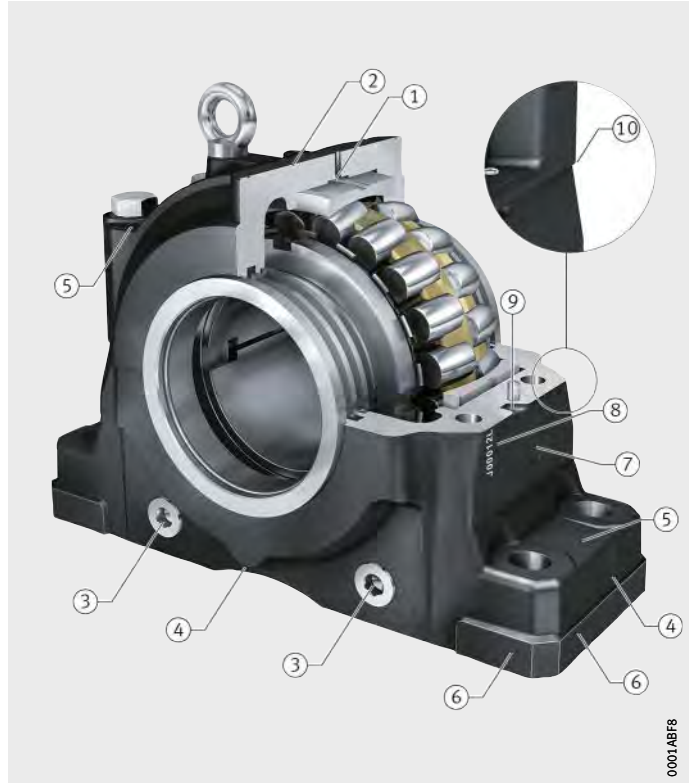

Figure 2
Advantages of detailed design

Lubrication hole with long axial lubrication groove



A lubrication hole with a long axial lubrication groove in the upper housing section ensures supply of lubricant irrespective of bearing position to all bearing series that can be fitted, *Figure 2*, ①. Suitable lubrication nipples are included in the scope of delivery.

Grease outlet holes

Grease outlet holes in the lower housing section allow the escape of used and superfluous grease during relubrication, *Figure 2*, ③.

Indentations indicating shaft and bearing centres

Indentations in the lower housing section indicate the shaft and bearing centres in the housing, *Figure 2*, ④. This allows rapid alignment and reduces mounting time.

Inclined run-off areas	Inclined run-off areas on the upper and lower housing section promote the removal of fluids and reduce deposits of contamination, <i>Figure 2</i> , ⑤. This leads to reduced cleaning work and a lower risk of corrosion.	
Machined locating faces	Machined locating faces on the lower housing section allow precise alignment of the housing, <i>Figure 2</i> , ⑥. When the housing is painted, the locating faces are also provided with a universal paint coating. Since the locating faces are raised, strips can be used as an alignment aid. One-off alignment is sufficient to allow rapid interchange of the housing when necessary.	
Prepared mounting points for condition monitoring	In order to allow the uncomplicated use of Condition Monitoring, the lower housing section has a connection facility on both sides for condition monitoring systems, <i>Figure 2</i> , ⑦. Due to the thread M6 and a flattened area on the diameter 26 mm, it is possible to directly connect FAG SmartCheck, a modular online measuring system for machine monitoring. Alternatively, other vibration sensors can also be connected. If neither of the two connection points is accessible as a result of the adjacent construction, a further suitable connection point on the upper section is indicated by a cast-in pilot hole, <i>Figure 2</i> , ②. FAG SmartCheck must be ordered separately. For detailed information, see TPI 214, FAG SmartCheck or www.FAG-SmartCheck.de .	
Marking of housing halves	The upper housing section and lower housing section are matched to each other and must not be transposed with other housing halves. The serial numbering on both halves of the housing ensure their correct allocation, <i>Figure 2</i> , ⑧. Furthermore, the serial numbering allows traceability and simplified documentation.	
Dismounting notches	Recessed dismounting notches on the interface of the housing halves make it easier to remove the upper housing section, <i>Figure 2</i> , ⑨.	
Projection of upper housing section	The projection of the upper housing section prevents the collection of fluids and contaminants at the interface of the two housing halves, <i>Figure 2</i> , ⑩. This leads to reduced cleaning work and a lower risk of corrosion.	

Split plummer block housings SNS

Seals and covers

For sealing of the bearing housings, the following standard seals are available:

- labyrinth seals and Taconite seals, each in a split and unsplit design. These seals are matched to the rectangular section annular slots on both sides of the housings SNS..-H and SNS..-Z.
- Bolt-on seals. These seals are screw mounted to the outside of housings SNS..-B.

If a housing closed on one side is required, the following covers are available:

- covers NDK, for housings SNS..-H and SNS..-Z
- covers BDK, for housings SNS..-B.

Seals and covers must be ordered specially. Seals are supplied individually. If a continuous shaft is present, two seals must be ordered.

Labyrinth seals NTS

Labyrinth seals NTS give non-contact sealing. They are therefore suitable for high circumferential velocities. The round cord made from fluoro rubber FKM pressed between the labyrinth ring and shaft is suitable for temperatures up to +200 °C.

The labyrinth seal allows shaft misalignment of up to 0,3° in both directions and is suitable for grease lubrication. If necessary, the labyrinth can be relubricated. For this purpose, a lubrication hole must be made in the upper housing section for each labyrinth seal. The optimum positions are indicated by cast-in pilot holes.

Taconite seals NTC

Taconite seals NTC are combined seals comprising a labyrinth seal and a V ring. These seals are suitable for extreme operating conditions in relation to contamination and dust. The V ring is made from NBR and is suitable for temperatures up to +100 °C.

The Taconite seal allows shaft misalignment of up to 0,3° in both directions and is suitable for grease lubrication. For relubrication, the seal is fitted with a lubrication nipple.

Split labyrinth seals NTSG

For plummer block housings SNS, labyrinth seals are also available in a split design. As a result, the work involved in replacing the seal can be considerably reduced, especially if a split bearing is also fitted.

The characteristics and operating limits correspond to those of the unsplit labyrinth seal NTS.

Split labyrinth seals NTSG are available in various sizes, see table, page 157. Other sizes are available by agreement.

Sizes

Sizes of split labyrinth seals for	
metric shaft	inch size shaft
NTSG34	NTSG34×515
NTSG36	NTSG36×607
NTSG38	–
NTSG40	–
NTSG44	–
NTSG48	–
NTSG52	–



Split Taconite seals NTCG

For plummer block housings SNS, Taconite seals are also available in a split design. As a result, the work involved in replacing the seal can be considerably reduced, especially if a split bearing is also fitted.

Split Taconite seals are supplied by agreement.

Bolt-on seals BTAC

Bolt-on seals BTAC are combined seals comprising a labyrinth seal and a V ring.

They are screw mounted to the outside of the housing and, unlike all other seals for plummer block housings SNS, are not inserted in the annular slots in the housing.

The seals are suitable for extreme operating conditions in relation to contamination and dust. The V ring is made from NBR and is suitable for temperatures up to +100 °C.

The Bolt-on seal allows shaft misalignment of up to 0,4° in both directions and is suitable for grease lubrication. For relubrication, the seal is fitted with a lubrication nipple.

The seals are available in the sizes BTAC34 to BTAC68.

When using Bolt-on seals, housings in a special design SNS..-B are required instead of the designs SNS..-H and SNS..-Z suitable for all other seals.

Covers NDK

Covers NDK are used with housings closed on one side. The covers fit in the rectangular section annular slots in the housings. They are suitable for temperatures up to +200 °C.

Covers BDK

Covers BDK are screw mounted to the outside of the housing. They are suitable for the housings SNS..-B designed for the Bolt-on seal.

Characteristics and operating limits

The characteristics and operating limits of the standard seals and covers are compared in an overview, see table, page 158.

Split plummer block housings SNS

Standard seals and covers for plummer block housings SNS

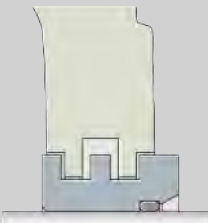
Seal or cover	Labyrinth seal	
		
Designation	NTS	
Material	Steel, FKM	
Pieces per pack	1	
Suitability for sealing against		
Dust	(+)	
Fine solid particles	+	
Coarse solid particles	+	
Slivers	++	
Spray liquids	–	
Operating limits		
Long term temperature	°C	–20 to +200 (due to FKM)
	°F	–4 to +390 (due to FKM)
Circumferential velocity	m/s	No restriction
Misalignment	°	≤ 0,3
Low friction		++
Axial shaft displacement (suitability as non-locating bearing)		+
Vertical arrangement		–
Suitability for grease relubrication		+
Suitability for oil lubrication		–
Compatibility with sunlight		++
Preconditions		
Shaft diameter tolerance ¹⁾		h8 (h9)
Shaft roughness	μm	Ra 3,2

++ Highly suitable

+ Suitable

(+) Suitable with restrictions

– Not suitable

¹⁾ The envelope condition © applies here.

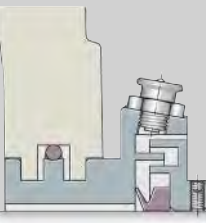
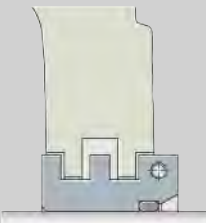
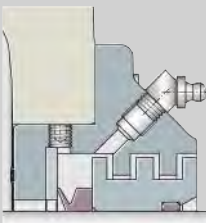
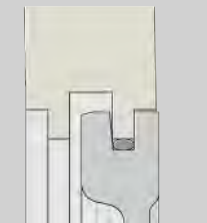
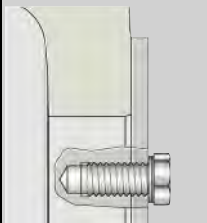
Taconite seal	Labyrinth seal, split	Bolt-on seal	Cover	
				
NTC	NTSG	BTAC	NDK	BDK
Steel, NBR	Steel, FKM	Steel, NBR	Steel, FKM	Steel
1	1	1	1	1
++	(+)	++	++	++
++	+	++	++	++
++	+	++	++	++
++	++	++	++	++
++	-	++	++	++
-30 to +100 (due to NBR)	-20 to +200 (due to FKM)	-30 to +100 (due to NBR)	-20 to +200 (due to FKM)	Not applicable
-22 to +210 (due to NBR)	-4 to +390 (due to FKM)	-22 to +210 (due to NBR)	-4 to +390 (due to FKM)	Not applicable
12	No restriction	12	Not applicable	Not applicable
≤ 0,3	≤ 0,3	≤ 0,4	Not applicable	Not applicable
+	++	+	Not applicable	Not applicable
+	+	+	Not applicable	Not applicable
(+)	-	-	++	++
+	+	++	++	++
(+)	-	-	+	-
++	++	++	++	++
h8 (h9)	h8 (h9)	h8 (h9)	Not applicable	Not applicable
Ra 3,2	Ra 3,2	Ra 3,2	Not applicable	Not applicable



Split plummer block housings SNS

Housing configurations

The modular structure of the plummer block housings SNS facilitates numerous possible combinations.

Based on the standard components, the housings can be combined as follows:

- location of bearings with a tapered bore by means of an adapter sleeve on a shaft of constant diameter or of bearings with a cylindrical bore directly on a stepped shaft
- sealing of housing by labyrinth seals (unsplit or split), Taconite seals (unsplit or split) or Bolt-on seals (in combination with housings of design SNS...B)
- with a continuous shaft or a housing closed on one side
- design of the bearing arrangement as a locating bearing arrangement or a non-locating bearing arrangement
- spherical roller bearing in a split or unsplit design.

The resulting possible housing configurations, *Figure 3* to *Figure 12*, page 162 make it possible to fulfil various requirements on the bearing positions by means of standard components.

- ① Locating bearing
- ② Non-locating bearing

Figure 3
Plummer block housing SNS for bearing with tapered bore and adapter sleeve (2 labyrinth seals NTS)

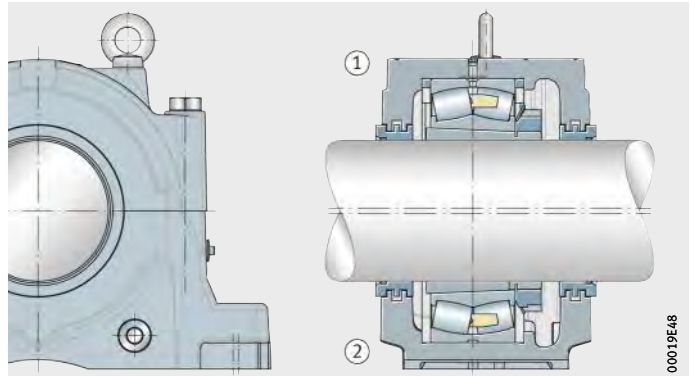

- ① Locating bearing
- ② Non-locating bearing

Figure 4
Plummer block housing SNS for bearing with tapered bore and adapter sleeve (labyrinth seal NTS and cover NDK)

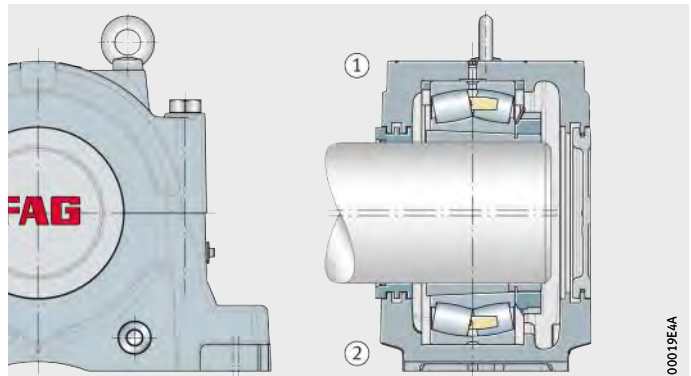

- ① Locating bearing
- ② Non-locating bearing

Figure 5
Plummer block housing SNS
for bearing with tapered bore and
adapter sleeve
(2 Taconite seals NTC)

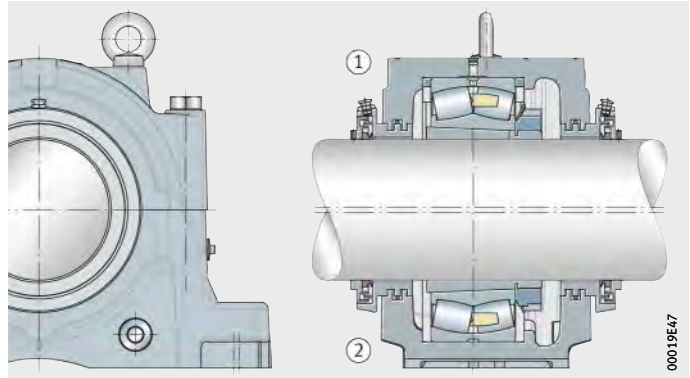

- ① Locating bearing
- ② Non-locating bearing

Figure 6
Plummer block housing SNS
for bearing with tapered bore and
adapter sleeve
(Taconite seal NTC and cover NDK)

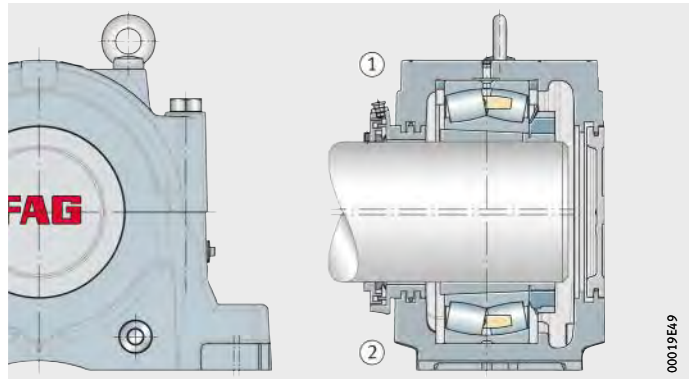

- ① Locating bearing
- ② Non-locating bearing

Figure 7
Plummer block housing SNS
for bearing with cylindrical bore
(2 labyrinth seals NTS)

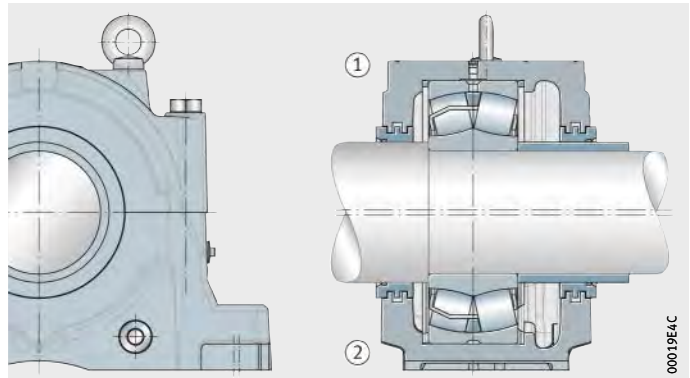

- ① Locating bearing
- ② Non-locating bearing

Figure 8
Plummer block housing SNS
for bearing with cylindrical bore
(labyrinth seal NTS and cover NDK)

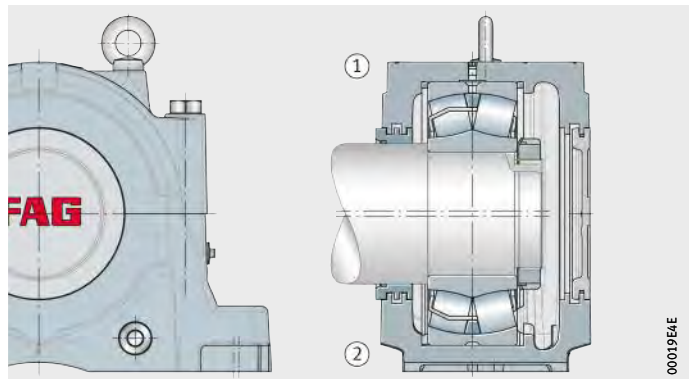

Split plummer block housings SNS

- ① Locating bearing
- ② Non-locating bearing

Figure 9
Plummer block housing SNS
for bearing with cylindrical bore
(2 Taconite seals NTC)

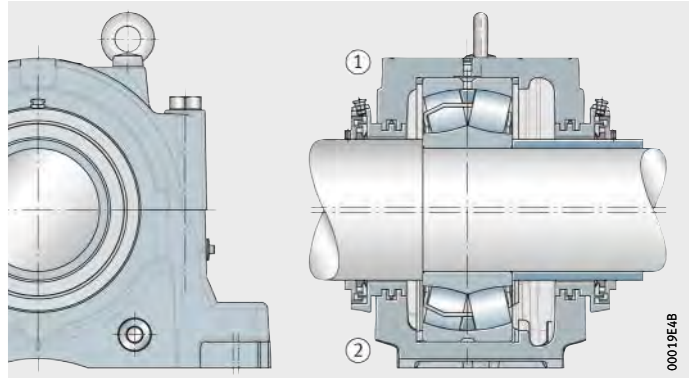

- ① Locating bearing
- ② Non-locating bearing

Figure 10
Plummer block housing SNS
for bearing with cylindrical bore
(Taconite seal NTC and cover NDK)

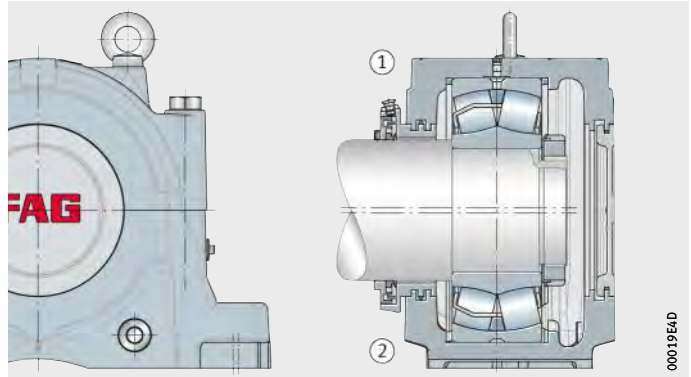

- ① Locating bearing
- ② Non-locating bearing

Figure 11
Plummer block housing SNS
for bearing with tapered bore and
adapter sleeve
(2 Bolt-on seals NTC)

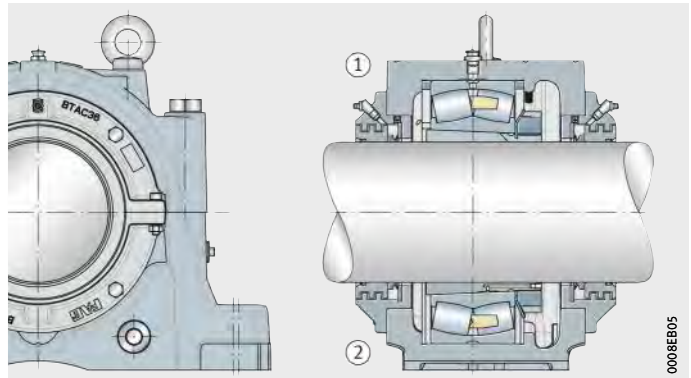

- ① Locating bearing
- ② Non-locating bearing

Figure 12
Plummer block housing SNS
for bearing with tapered bore and
adapter sleeve
(Bolt-on seal BTAC and cover BDK)

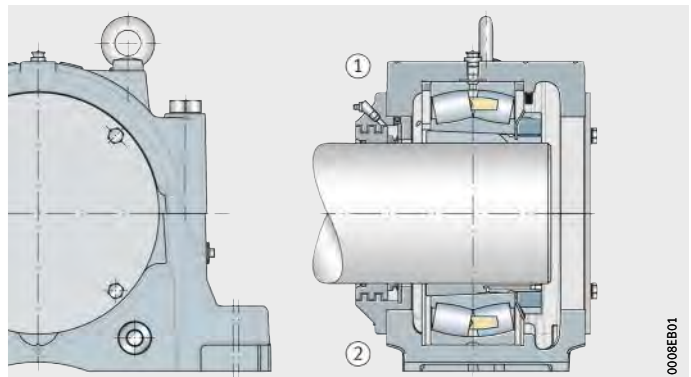

Mounting of split spherical roller bearings

In the case of plummer block housings SNS, an unsplit spherical roller bearing with a tapered bore and adapter sleeve can be replaced by a split spherical roller bearing, *Figure 13*.

- ① Locating bearing with unsplit bearing
- ② Non-locating bearing with unsplit bearing
- ③ Locating bearing with split bearing
- ④ Non-locating bearing with split bearing

Figure 13
Plummer block housing SNS with split and unsplit spherical roller bearing

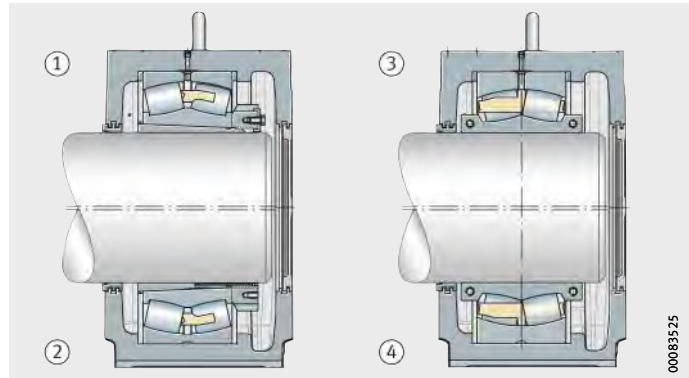

Combination with products for maintenance

The housings are suitable for connection of systems for preventive maintenance such as Condition Monitoring or automatic lubricators. Schaeffler offers a wide range of such products.

Further information on maintenance products

- Catalogue IS 1, Mounting and Maintenance of Rolling Bearings.



00083525

Split plummer block housings SNS

Lubrication Split plummer block housings SNS are principally intended for grease lubrication. However, a design for oil lubrication is also available by agreement.

Greases In order to achieve a long operating life and high operational security of the bearing arrangement, we recommend the use of Arcanol rolling bearing greases, see section Rolling bearing greases Arcanol, page 419. These have been designed and tested for bearing arrangement engineering.

Grease quantity For initial greasing, the basic rule is that the bearing should be filled with grease to 100% and the free volume of the housing to 60%. The free volume is the space that remains in the housing once the bearing, adapter sleeve, shaft and seals have been fitted. The recommended grease quantity can also be stated in grams once the density of the grease has been taken into consideration, see table.

The recommended grease quantity in the table takes account of the following:

- filling of the free volume to 60%
- grease with a density of 0,9 g/cm³.

Recommended grease quantity for selected housing/bearing combinations

Housing	Bearing	Adapter sleeve	Free volume (100%) cm ³	Recommended grease quantity ≈ g	
SNS22	SNS2264-H-D	22264..-K	H3064	27 550	14 900
SNS30	SNS3036-H-D	23036..-K	H3036	2 900	1 600
	SNS3038-H-D	23038..-K	H3038	3 900	2 250
	SNS3040-H-D	23040..-K	H3040	5 020	3 050
	SNS3044-H-D	23044..-K	H3044	5 770	4 260
	SNS3048-H-D	23048..-K	H3048	7 280	4 550
	SNS3052-H-D	23052..-K	H3052	9 930	6 750
	SNS3056-H-D	23056..-K	H3056	12 500	6 750
	SNS3060-H-D	23060..-K	H3060	14 800	8 000
	SNS3064-H-D	23064..-K	H3064	19 400	10 500
	SNS3068-H-D	23068..-K	H3068	24 000	13 000
	SNS3072-H-D	23072..-K	H3072	30 400	16 450
	SNS3076-H-D	23076..-K	H3076	32 000	17 300
	SNS3080-H-D	23080..-K	H3080	33 500	18 100
	SNS3084-H-D	23084..-K	H3084	35 000	18 900
	SNS3088-H-D	23088..-K	H3088	43 400	23 450
	SNS3092-H-D	23092..-K	H3092	56 600	30 600
	SNS3096-H-D	23096..-K	H3096	55 200	29 850
	SNS30/500-H-D	230/500..-K	H30/500	55 200	29 850
	SNS30/530-H-D	230/530..-K	H30/530	67 500	36 450

**Recommended grease quantity
for selected housing/bearing
combinations
(continued)**

Housing	Bearing	Adapter sleeve	Free volume (100%) cm ³	Recommended grease quantity ≈ g	
SNS31	SNS3134-H-D	23134..-K	H3134	2 900	1 600
	SNS3136-H-D	23136..-K	H3136	3 810	2 060
	SNS3138-H-D	23138..-K	H3138	5 030	2 720
	SNS3140-H-D	23140..-K	H3140	6 780	3 660
	SNS3144-H-D	23144..-K	H3144	7 520	4 060
	SNS3148-H-D	23148..-K	H3148	10 100	5 990
	SNS3152-H-D	23152..-K	H3152	11 650	6 300
	SNS3156-H-D	23156..-K	H3156	12 550	6 800
	SNS3160-H-D	23160..-K	H3160	17 200	9 300
	SNS3164-H-D	23164..-K	H3164	21 250	11 500
	SNS3168-H-D	23168..-K	H3168	27 550	14 900
	SNS3172-H-D	23172..-K	H3172	28 500	15 400
	SNS3176-H-D	23176..-K	H3176	28 300	15 300
	SNS3180-H-D	23180..-K	H3180	36 450	19 700
	SNS3184-H-D	23184..-K	H3184	45 550	24 600
	SNS3188-H-D	23188..-K	H3188	48 300	26 100
SNS3192-H-D	23192..-K	H3192	52 000	28 100	
SNS3196-H-D	23196..-K	H3196	55 000	29 700	
SNS32	SNS3234-H-D	23234..-K	H2334	5 350	2 900
	SNS3236-H-D	23236..-K	H2336	5 350	2 900
	SNS3238-H-D	23238..-K	H2338	6 500	3 510
	SNS3240-H-D	23240..-K	H2340	6 900	3 760
	SNS3244-H-D	23244..-K	H2344	10 000	5 400
	SNS3248-H-D	23248..-K	H2348	10 200	5 550
	SNS3252-H-D	23252..-K	H2352	15 500	8 400
	SNS3256-H-D	23256..-K	H2356	15 500	8 400
	SNS3260-H-D	23260..-K	H3260	19 000	10 300
	SNS3264-H-D	23264..-K	H3264	25 300	13 700
	SNS3268-H-D	23268..-K	H3268	25 000	13 500
	SNS3272-H-D	23272..-K	H3272	26 800	14 500
	SNS3276-H-D	23276..-K	H3276	38 600	20 850
	SNS3280-H-D	23280..-K	H3280	44 100	23 850
	SNS3284-H-D	23284..-K	H3284	45 000	24 350
	SNS3288-H-D	23288..-K	H3288	49 400	26 700

Information on the recommended grease quantity for other housing sizes is available by agreement.

The recommended degree of filling for the greasing of bearings, as a function of the application and speed, may deviate from 100%.



Split plummer block housings SNS

Relubrication Where relubrication is carried out on bearings with a circumferential lubrication groove, the grease is introduced into the housing via the central lubrication hole, *Figure 14*, page 167, ①. In this type of relubrication, the grease acts directly on the bearing.

For the relubrication of bearings without a lubrication groove, two relubrication points are provided in the upper housing section, *Figure 14*, ②. One of the two points has a threaded hole, while the other is indicated by a cast-in pilot hole.

The lubrication holes and lubrication nipples provided for relubrication differ according to the design of the housing, see table. In the case of housings SNS..-H and SNS..-Z, the threaded holes are closed off by a screw plug. This must be removed and permanently replaced by one of the lubrication nipples supplied. In the case of housings SNS..-B, both taper type lubrication nipples are already fitted.

Lubrication holes and lubrication nipples

Housing	Thread	Lubrication nipple	Delivery quantity
SNS..-H SNS..-Z	M10×1	Button head lubrication nipple in accordance with DIN 3404-M10×1 (with dust cap)	1
		Taper type lubrication nipple in accordance with DIN 71412-AM10×1 (with dust cap)	1
SNS..-B	ISO 288-G1/4	Button head lubrication nipple in accordance with DIN 3404-A G1/4 St	2

Lubrication holes can be provided at two further points for relubrication of labyrinth seals, *Figure 14*, ③.

In order to prevent overgreasing, the screw plugs must be removed from the two grease outlet holes in the lower housing section for the duration of relubrication, *Figure 14*, ④. This allows superfluous grease to escape. The grease outlet holes must then be closed off again using the screw plugs.

- ① Central lubrication hole, for bearings with lubrication groove
- ② Points for relubrication of bearings without lubrication groove
- ③ Points for relubrication of labyrinth seals
- ④ Grease outlet holes

Figure 14
Points for relubrication

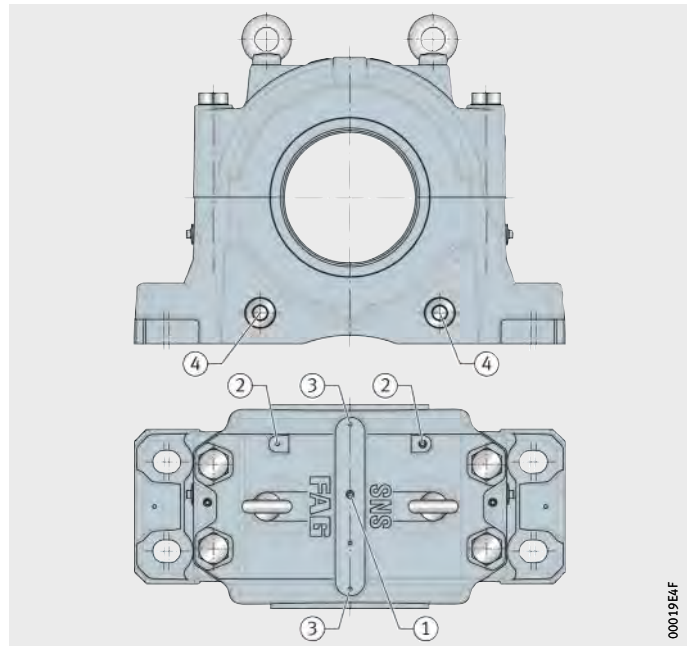

If unfavourable environmental conditions are present, there is therefore a risk of contamination being carried into the housing when the grease outlet holes are opened.

Split plummer block housings SNS

Designation structure

The designation structure for split plummer block housings SNS and accessories is shown in the tables and *Figure 15* to *Figure 18*, page 171.

Designation structure of plummer block housings SNS

Feature	Code	Description
① Series	SNS	Split plummer block housings SNS
② ISO dimension series of bearing	30	ISO dimension series 22, 23, 30 and 40
	31	ISO dimension series 22, 23 and 31
	32	ISO dimension series 22 and 32
	40	ISO dimension series 40
③ Housing size	36	For bearings of ISO dimension series 30, 31 and 32: ■ Bore code of bearing
	/530	
④ Housing design	H	Main design, see table, page 169
	Z	Additional design, see table, page 169
	B	Design for Bolt-on seal
⑤ Housing material	D	Spheroidal graphite cast iron



Figure 15
Designation structure of plummer block housings SNS, example

Plummer block housings SNS with labyrinth and Taconite seals are available in the housing designs H and Z. Spherical roller bearings can be fitted, as a function of the bearing series, in one of the two housing designs, see table.



Allocation of housing designs H and Z to bearing types

Housing design	Bearing series
H	Spherical roller bearings with tapered bore and adapter sleeve
	Split spherical roller bearings
	Following spherical roller bearings with cylindrical bore: 22232, 22234, 22252, 22272, 22326, 22328, 22330, 22332, 22334, 22338, 22344, 22348, 22352, 22356, 23232, 24036
Z	Spherical roller bearings with cylindrical bore, not allocated to housing design H



Split plummer block housings SNS

Designation structure of standard seals

Feature	Code	Description
① Series	NTS	Labyrinth seal
	NTC	Taconite seal
	NTSG	Split labyrinth seal
	NTCG	Split Taconite seal
	BTAC	Bolt-on seal
② Dimension series	36	Dimension series 36
③ Shaft diameter	No further indications	Standard shaft diameter of dimension series
	/125	Metric shaft diameter: ■ 125 mm
	X415	Inch size shaft diameter: ■ 4 inch + 15 · 1/16 inch = 4 ¹⁵ /16 inch



Figure 16
Designation structure of standard seals, examples

Designation structure of covers

Feature	Code	Description
① Series	NDK	Cover for plummer block housings SNS...-H and SNS...-Z.
	BDK	Cover for plummer block housing SNS...-B
② Dimension series	36	Dimension series 36

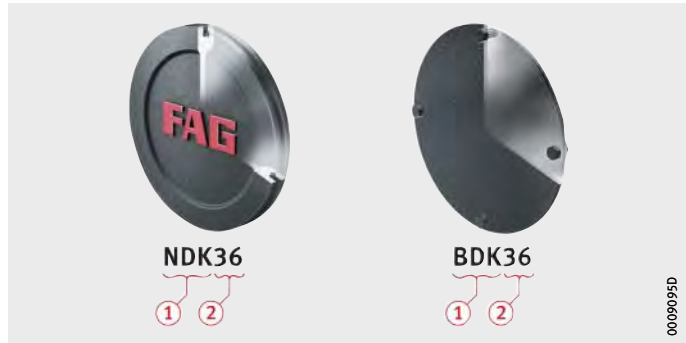

Figure 17
Designation structure of covers, example

Designation structure of locating rings

Feature	Code	Description
① Series	NFR	Locating ring
② Outside diameter	280	Outside diameter 280 mm
③ Width	10	Width 10 mm

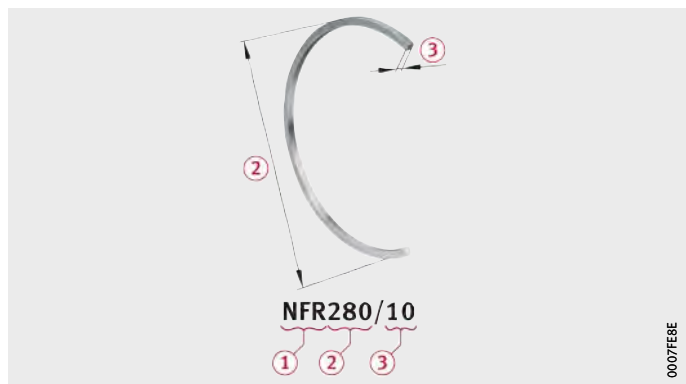

Figure 18
Designation structure of locating rings, example



Split plummer block housings SNS

Ordering examples

When a split plummer block housing SNS is ordered, the housing designation only describes the housing body. The other components such as seals, covers or locating rings must be ordered separately in the specific design required. The rolling bearing and, if necessary, the adapter sleeve must also be ordered separately.

Plummer block housings SNS with a bearing fitted give non-locating bearing arrangements. These can be converted into locating bearing arrangements through the additional insertion of locating rings NFR.

The ordering examples show the construction of orders for selected housing combinations and the appropriate bearings. The allocation of housings, bearings and accessories for all housing sizes is shown in the dimension tables.

Example 1 Plummer block housing SNS made from spheroidal graphite cast iron, closed on one side, spherical roller bearing 23136-E1A-K-M as locating bearing, location by means of adapter sleeve on shaft diameter 160 mm, labyrinth seal.

Order	1 plummer block housing	SNS3136-H-D
	1 spherical roller bearing	23136-E1A-K-M
	1 adapter sleeve	H3136-HG
	2 locating rings	NFR300/10
	1 cover	NDK36
	1 labyrinth seal	NTS36

Example 2 Plummer block housing SNS made from spheroidal graphite cast iron, continuous shaft, spherical roller bearing 23136-E1A-K-M as non-locating bearing, location by means of adapter sleeve on shaft diameter 160 mm, Taconite seal.

Order	1 plummer block housing	SNS3136-H-D
	1 spherical roller bearing	23136-E1A-K-M
	1 adapter sleeve	H3136-HG
	2 Taconite seals	NTC36

Example 3 Plummer block housing SNS made from spheroidal graphite cast iron, closed on one side, spherical roller bearing 23136-E1A-K-M as non-locating bearing, location by means of adapter sleeve on shaft diameter 160 mm, Bolt-on seal.

Order	1 plummer block housing	SNS3136-B-D
	1 spherical roller bearing	23136-E1A-K-M
	1 adapter sleeve	H3136-HG
	1 cover	BDK36
	1 Bolt-on seal	BTAC36

Design and safety guidelines

Load carrying capacity

Guide values have been determined for the rupture load of plummer block housings SNS and the maximum load carrying capacity of connecting screws for the upper and lower housing sections, *Figure 19* and table, page 174. The guide values are valid for purely static loading.

The guide values in the table, page 174, are only valid if the flatness of the mounting surface in accordance with DIN EN ISO 1101 corresponds to the tolerance grade IT7 in accordance with DIN EN ISO 286-1 (measured across the diagonal). A precondition for supporting loads is that the housing base surface is completely and rigidly supported.

When determining the permissible static load, safety factors must be applied. For general machine building, a safety factor of 6 relative to the housing rupture load is normally applied. Based on the precise calculation of the housing rupture loads using the Finite Element method and the use as standard of spheroidal graphite cast iron as the housing material, a safety factor of 5 is sufficient for plummer block housings SNS.

A safety factor is not required for the values given for the load carrying capacity of the connecting screws.



If the housing is subjected to axial load, the permissible axial load of the bearing fitted must be taken into consideration. If the bearing is located on the shaft using an adapter sleeve, the axial retaining force of the bearing and adapter sleeve must also be taken into consideration.

If the load direction is between 55° and 120° or axial load is present, we recommend that the housings should be secured in the load direction by means of stops.

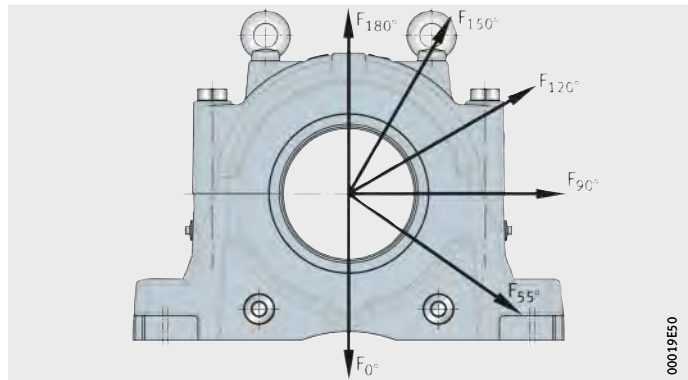

Figure 19
Load directions F
for the guide values
for the housing rupture load and
the maximum load carrying capacity
of the connecting screws



Split plummer block housings SNS

Guide values
for housing rupture load and
maximum load carrying capacity
of connecting screws,
as well as tightening torques

Designation, housing					Housing rupture loads ¹⁾ in load direction F	
SNS22	SNS30	SNS31	SNS32	SNS40	0° kN	55° kN
–	SNS3036	SNS3134	–	–	4 050	4 540
–	SNS3038	SNS3136	–	–	4 400	4 940
–	SNS3040	SNS3138	SNS3234	–	4 880	5 480
–	–	–	SNS3236	–	4 880	5 480
–	SNS3044	SNS3140	SNS3238	–	5 800	6 500
–	SNS3048	SNS3144	SNS3240	–	6 240	7 560
–	SNS3052	SNS3148	–	–	7 330	8 550
–	–	–	SNS3244	–	7 330	8 550
–	SNS3056	SNS3152	–	–	8 740	9 810
–	–	–	SNS3248	–	8 740	9 810
–	SNS3060	SNS3156	–	–	9 200	10 320
–	SNS3064	SNS3160	–	–	10 150	11 390
–	–	–	SNS3252	–	10 150	11 390
–	–	–	SNS3256	–	10 150	11 390
–	SNS3068	SNS3164	–	–	11 410	12 810
–	SNS3072	–	–	–	11 410	12 810
–	–	–	SNS3260	–	11 410	12 810
SNS2264	SNS3076	SNS3168	–	SNS4076	13 300	14 930
–	–	–	SNS3264	–	13 300	14 930
–	SNS3080	SNS3172	–	–	14 740	16 540
–	–	–	–	SNS4080	14 740	16 540
–	SNS3084	SNS3176	–	–	15 940	17 890
–	–	–	SNS3268	–	15 940	17 890
–	–	–	–	SNS4084	15 940	17 890
–	SNS3088	SNS3180	–	–	18 490	20 750
–	–	–	SNS3272	–	18 490	20 750
–	–	–	–	SNS4088	18 490	20 750
–	SNS3092	SNS3184	–	SNS4092	20 180	22 650
–	SNS3096	–	–	SNS4096	20 180	22 650
–	–	–	SNS3276	–	20 180	22 650
–	SNS30/500	SNS3188	–	–	21 940	24 620
–	–	–	SNS3280	–	21 940	24 620
–	–	–	–	SNS40/500	21 940	24 620
–	–	SNS3192	–	–	24 150	27 100
–	–	–	SNS3284	–	24 150	27 100
–	SNS30/530	SNS3196	–	SNS40/530	26 080	29 270
–	–	–	SNS3288	–	26 080	29 270

¹⁾ For housings made from spheroidal graphite cast iron GJS-400-15 (suffix D).

					Connecting screws						
					Screws in accordance with DIN EN ISO 4014	Tightening torque	Maximum load carrying capacity of the four screws with contact between parting surfaces in load direction F				
90°	120°	150°	180°	axial			Material 8.8	90°	120°	150°	180°
kN	kN	kN	kN	kN		Nm	kN	kN	kN	kN	
3 040	1 650	1 190	1 220	1 170	M24	559	1 380	760	618	725	
3 300	1 800	1 300	1 330	1 270	M24	559	1 370	760	615	723	
3 660	1 990	1 440	1 470	1 410	M24	559	1 500	830	670	790	
3 660	1 990	1 440	1 470	1 410	M24	559	1 500	830	670	790	
4 350	2 370	1 700	1 750	1 670	M24	559	1 510	836	677	796	
5 070	2 880	2 360	2 380	1 880	M24	559	1 484	820	664	781	
5 720	3 190	2 470	2 510	2 080	M30	1 118	2 380	1 315	1 065	1 252	
5 720	3 190	2 470	2 510	1 880	M30	1 118	2 380	1 315	1 065	1 252	
6 550	3 570	2 580	2 640	2 520	M30	1 118	2 372	1 310	1 061	1 250	
6 550	3 570	2 580	2 640	1 410	M30	1 118	2 372	1 310	1 061	1 250	
6 900	3 760	2 710	2 780	2 652	M30	1 118	2 330	1 290	1 040	1 230	
7 620	4 150	3 000	3 070	2 810	M30	1 118	2 220	1 230	990	1 170	
7 620	4 150	3 000	3 070	2 230	M30	1 118	2 220	1 230	990	1 170	
7 620	4 150	3 000	3 070	2 230	M30	1 118	2 220	1 230	990	1 170	
8 560	4 660	3 370	3 450	3 355	M30	1 118	2 220	1 230	1 000	1 170	
8 560	4 660	3 370	3 450	3 355	M30	1 118	2 200	1 230	1 000	1 170	
8 560	4 660	3 370	3 450	2 900	M30	1 118	2 200	1 230	1 000	1 170	
9 980	5 430	3 930	4 020	3 480	M36	1 945	3 260	1 800	1 460	1 720	
9 980	5 430	3 930	4 020	2 690	M36	1 945	3 260	1 800	1 460	1 720	
11 060	6 020	4 350	4 450	4 250	M36	1 945	3 100	1 710	1 390	1 630	
11 060	6 020	4 350	4 450	4 295	M36	1 945	3 100	1 710	1 390	1 630	
11 960	6 510	4 710	4 820	4 600	M36	1 945	3 100	1 710	1 390	1 630	
11 960	6 510	4 710	4 820	3 628	M36	1 945	3 100	1 710	1 390	1 630	
11 960	6 510	4 710	4 820	4 200	M36	1 945	3 100	1 710	1 390	1 630	
13 870	7 560	5 460	5 590	5 330	M36	1 945	3 200	1 770	1 430	1 690	
13 870	7 560	5 460	5 590	3 200	M36	1 945	3 200	1 770	1 430	1 690	
13 870	7 560	5 460	5 590	4 535	M36	1 945	3 200	1 770	1 430	1 690	
15 140	8 250	5 960	6 100	5 650	M42	2 794	4 110	2 270	1 840	2 160	
15 140	8 250	5 960	6 100	5 650	M42	2 794	4 110	2 270	1 840	2 160	
15 140	8 250	5 960	6 100	4 530	M42	2 794	4 110	2 270	1 840	2 160	
16 460	8 970	6 480	6 630	6 320	M42	2 794	4 110	2 270	1 840	2 160	
16 460	8 970	6 480	6 630	4 360	M42	2 794	4 110	2 270	1 840	2 160	
16 460	8 970	6 480	6 630	6 350	M42	2 794	4 110	2 270	1 840	2 160	
18 120	9 870	7 130	7 300	6 962	M42	2 794	4 160	2 300	1 860	2 190	
18 120	9 870	7 130	7 300	4 747	M42	2 794	4 160	2 300	1 860	2 190	
19 560	10 660	7 700	7 880	7 420	M42	2 794	4 160	2 300	1 860	2 190	
19 560	10 660	7 700	7 880	4 500	M42	2 794	4 160	2 300	1 860	2 190	



Split plummer block housings SNS

Permissible shaft end designs

In the case of a housing closed on one side, the length of the shaft in the housing must be restricted such that no contact occurs between the shaft and the cover. In this case, the displacement facility of the bearing in a non-locating bearing arrangement must be taken into consideration. The basis for determining the permissible length of the shaft is the spacing between the centre of the bearing seat and the cover, *Figure 20* and table.

a_d = spacing between
centre of bearing seat and cover

Figure 20
Spacing between
centre of bearing seat and cover

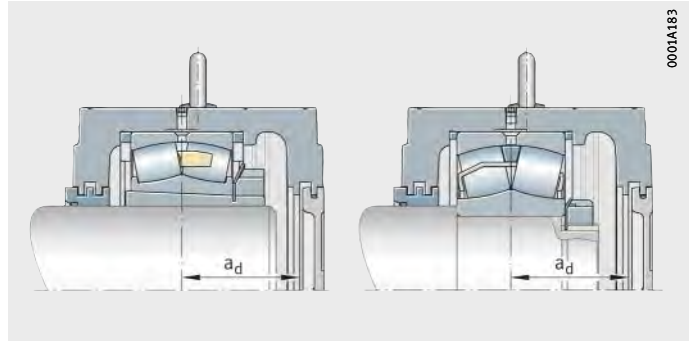

Spacing between
centre of bearing seat and cover

Housing					Spacing
SNS22	SNS30	SNS31	SNS32	SNS40	a_d mm
–	SNS3036	SNS3134	–	–	107,5
–	SNS3038	SNS3136	–	–	113,5
–	SNS3040	SNS3138	SNS3234	–	117,5
–	–	–	SNS3236	–	117,5
–	SNS3044	SNS3140	SNS3238	–	127,5
–	SNS3048	SNS3144	SNS3240	–	133,5
–	SNS3052	SNS3148	SNS3244	–	141,5
–	SNS3056	SNS3152	SNS3248	–	151,5
–	SNS3060	SNS3156	–	–	154,5
–	SNS3064	SNS3160	SNS3252	–	175,5
–	–	–	SNS3256	–	175,5
–	SNS3068	SNS3164	SNS3260	–	186,5
–	SNS3072	–	–	–	186,5
SNS2264	SNS3076	SNS3168	SNS3264	SNS4076	202,5
–	SNS3080	SNS3172	SNS3268	SNS4080	208,5
–	SNS3084	SNS3176	–	SNS4084	208,5
–	SNS3088	SNS3180	SNS3272	SNS4088	223,5
–	SNS3092	SNS3184	SNS3276	SNS4092	243,5
–	SNS3096	SNS3188	SNS3280	SNS4096	243,5
–	SNS30/500	–	–	SNS40/500	243,5
–	SNS30/530	SNS3192	SNS3284	SNS40/530	248,5
–	–	SNS3196	SNS3288	–	248,5

Eye bolts

The upper housing section has 2 eye bolts in accordance with DIN 580. These are intended as locating points for mounting and dismantling of the housing. The load carrying capacity of the eye bolts allows lifting of the housing including a bearing fitted in the housing.



Eye bolts must always be screwed fully into the housing. The eye bolt must not be subjected to a mass greater than that of the housing together with the bearing fitted in the housing.



Foot screws

Foot screws are used for screw mounting of the housing to the locating surface. They are not included in the scope of delivery of the housings.

The appropriate screw size for each housing is stated, see dimension tables.

The associated tightening torques are stated for screws with a metric thread in accordance with DIN 13, DIN 962 and DIN ISO 965-2, see table, page 42.



Mounting and dismantling

The fundamental requirements for the mounting and dismantling of bearing housings apply, see section Mounting and dismantling, page 39. Furthermore, there is a separate mounting manual for split plummer block housings SNS.

Further information

■ MON 84, Split Plummer Block Housings SNS – Mounting Manual.

Accuracy

The bearing seat in split plummer block housings SNS is machined to the tolerance class G7.

By agreement, the housings can also be supplied with other tolerance classes for the bearing seat, see section Tolerance class of bearing seat, page 47.

Plummer block housings

SNS, split
For spherical roller bearings with tapered bore and adapter sleeve
Metric shaft

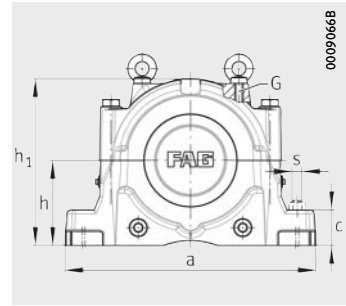
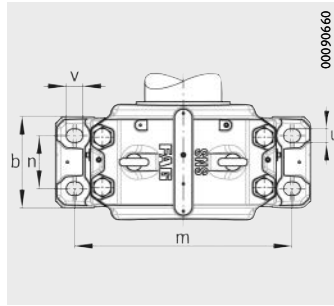

Dimension table - Dimensions in mm

Shaft d_1	Housing Dimensions														Spherical roller bearing and accessories	
	h	h ₁	g	b	c	a	m	n	v	u	s	D	k	e	Bearing	Adapter sleeve
115	170	333	230	180	70	510	430	100	34	28	M24	280	108	14	22326..-K	H2326
125	180	353	240	190	75	530	450	110	34	28	M24	300	116	15	22328..-K	H2328
135	190	375	260	210	80	560	480	120	34	28	M24	320	124	10	22330..-K	H2330
140	180	353	240	190	75	530	450	110	34	28	M24	290	115	15	22322..-K	H3132(-HG)
140	210	411	280	230	85	610	510	130	42	35	M30	340	132	10	22332..-K	H2332(-HG)
140	180	353	240	190	75	530	450	110	34	28	M24	290	115	15	23232..-K	H2332(-HG)
150	190	375	260	210	80	560	480	120	34	28	M24	310	122	10	22234..-K	H3134(-HG)
150	220	434	290	240	90	640	540	140	42	35	M30	360	140	12	22334..-K	H2334(-HG)
150	170	333	230	180	70	510	430	100	34	28	M24	280	108	14	23134..-K	H3134(-HG)
150	170	333	230	180	70	510	430	100	34	28	M24	280	108	14	231SM150-MA¹⁾	–
150	190	375	260	210	80	560	480	120	34	28	M24	310	122	10	23234..-K	H2334(-HG)
160	190	375	260	210	80	560	480	120	34	28	M24	320	124	10	22236..-K	H3136(-HG)
160	170	333	230	180	70	510	430	100	34	28	M24	280	108	14	23036..-K	H3036(-HG)
160	170	333	230	180	70	510	430	100	34	28	M24	280	108	14	230SM160-MA¹⁾	–
160	180	353	240	190	75	530	450	110	34	28	M24	300	116	15	23136..-K	H3136(-HG)
160	180	353	240	190	75	530	450	110	34	28	M24	300	116	15	231SM160-MA¹⁾	–
160	190	375	260	210	80	560	480	120	34	28	M24	320	124	10	23236..-K	H2336(-HG)
170	210	411	280	230	85	610	510	130	42	35	M30	340	132	10	22238..-K	H3138(-HG)
170	240	474	310	260	95	700	600	150	42	35	M30	400	148	12	22338..-K	H2338(-HG)
170	180	353	240	190	75	530	450	110	34	28	M24	290	115	15	23038..-K	H3038(-HG)
170	180	353	240	190	75	530	450	110	34	28	M24	290	115	15	230SM170-MA¹⁾	–
170	190	375	260	210	80	560	480	120	34	28	M24	320	124	10	23138..-K	H3138(-HG)
170	190	375	260	210	80	560	480	120	34	28	M24	320	124	10	231SM170-MA	–
170	210	411	280	230	85	610	510	130	42	35	M30	340	132	10	23238..-K	H2338(-HG)

① Locating bearing; ② Non-locating bearing

- 1) Split bearing in associated housing has restricted usability. Please ask for further information.
- 2) Alternatively also available with split labyrinth seal NTSG.
- 3) With NTSG: width g_L increased by 16 mm.
- 4) With NTSG: width g_{LD} increased by 8 mm.

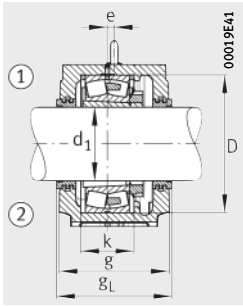

Labyrinth seal NTS

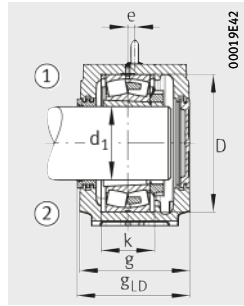

Labyrinth seal NTS
Cover NDK

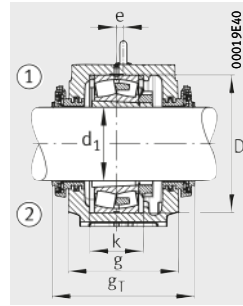

Taconite seal NTC

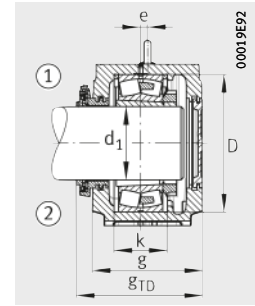

Taconite seal NTC
Cover NDK



									Housing		
Locating ring		Labyrinth seal			Taconite seal			Cover	G	Mass m ≈ kg	Designation
	Quantity		gL mm	gLD mm		gT mm	gTD mm				
NFR280/7,5	2	NTS34/115	241	235,5	NTC34/115	299	264	NDK34	M16	75	SNS3134-H-D
NFR300/7	2	NTS36/125	251	245,5	NTC36/125	310	274,5	NDK36	M16	83	SNS3136-H-D
NFR320/8	2	NTS38/135	271	265,5	NTC38/135	330	294,5	NDK38	M20	102	SNS3138-H-D
NFR290/17,5	2	NTS38/140	251	245,5	NTC38/140	312	275,5	NDK38	M16	86	SNS3038-H-D
NFR340/9	2	NTS40/140	291	285,5	NTC40/140	347	313	NDK40	M20	133	SNS3140-H-D
NFR290/5,5	2	NTS38/140	251	245,5	NTC38/140	312	275,5	NDK38	M16	86	SNS3038-H-D
NFR310/18	2	NTS40/150	271	265,5	NTC40/150	326	293	NDK40	M20	105	SNS3040-H-D
NFR360/10	2	NTS48/150	301	295,5	NTC48/150	380	335	NDK48	M20	148	SNS3048-H-D
NFR280/10	2	NTS34 ²⁾	241 ³⁾	235,5 ⁴⁾	NTC34	299	264,5	NDK34	M16	75	SNS3134-H-D
NFR280/10	2	NTS34 ²⁾	241 ³⁾	235,5 ⁴⁾	NTC34	299	264,5	NDK34	M16	75	SNS3134-H-D
NFR310/6	2	NTS40/150	271	265,5	NTC40/150	327	293	NDK40	M20	105	SNS3234-H-D
NFR320/19	2	NTS38/160	271	265,5	NTC38/160	329	294,5	NDK38	M20	102	SNS3138-H-D
NFR280/17	2	NTS36 ²⁾	241 ³⁾	235,5 ⁴⁾	NTC36	304	267	NDK36	M16	74	SNS3036-H-D
NFR280/17	2	NTS36 ²⁾	241 ³⁾	235,5 ⁴⁾	NTC36	304	267	NDK36	M16	74	SNS3036-H-D
NFR300/10	2	NTS36 ²⁾	251 ³⁾	245,5 ⁴⁾	NTC36	314	277	NDK36	M16	83	SNS3136-H-D
NFR300/10	2	NTS36 ²⁾	251 ³⁾	245,5 ⁴⁾	NTC36	314	277	NDK36	M16	83	SNS3136-H-D
NFR320/6	2	NTS38/160	271	265,5	NTC38/160	330	294,5	NDK38	M20	102	SNS3236-H-D
NFR340/10	4	NTS40/170	291	285,5	NTC40/170	346	313	NDK40	M20	133	SNS3140-H-D
NFR400/8	2	NTS48/170	321	315,5	NTC48/170	401	355	NDK48	M24	184	SNS3148-H-D
NFR290/10	4	NTS38 ²⁾	251 ³⁾	245,5 ⁴⁾	NTC38	312	275,5	NDK38	M16	86	SNS3038-H-D
NFR290/10	4	NTS38 ²⁾	251 ³⁾	245,5 ⁴⁾	NTC38	312	275,5	NDK38	M16	86	SNS3038-H-D
NFR320/10	2	NTS38 ²⁾	271 ³⁾	265,5 ⁴⁾	NTC38	334	297	NDK38	M20	102	SNS3138-H-D
NFR320/10	2	NTS38 ²⁾	271 ³⁾	265,5 ⁴⁾	NTC38	334	297	NDK38	M20	102	SNS3138-H-D
NFR340/6	2	NTS40/170	291	285,5	NTC40/170	347	313	NDK40	M20	133	SNS3238-H-D

Plummer block housings

SNS, split
 For spherical roller bearings with tapered bore and adapter sleeve
 Metric shaft

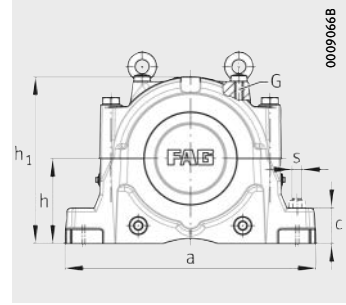
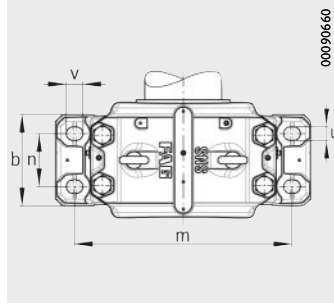

Dimension table (continued) · Dimensions in mm

Shaft d_1	Housing Dimensions														Spherical roller bearing and accessories	
	h	h_1	g	b	c	a	m	n	v	u	s	D	k	e	Bearing	Adapter sleeve
180	220	434	290	240	90	640	540	140	42	35	M30	360	140	12	22240..-K	H3140(-HG)
180	260	516	320	280	100	770	650	160	50	42	M36	420	166	13	22340..-K	H2340(-HG)
180	190	375	260	210	80	560	480	120	34	28	M24	310	122	10	23040..-K	H3040(-HG)
180	190	375	260	210	80	560	480	120	34	28	M24	310	122	10	230SM180-MA¹⁾	–
180	210	411	280	230	85	610	510	130	42	35	M30	340	132	10	23140..-K	H3140(-HG)
180	210	411	280	230	85	610	510	130	42	35	M30	340	132	10	231SM180-MA	–
180	220	434	290	240	90	640	540	140	42	35	M30	360	140	12	23240..-K	H2340(-HG)
200	240	474	310	260	95	700	600	150	42	35	M30	400	148	12	22244..-K	H3144X(-HG)
200	280	550	320	280	105	790	670	160	50	42	M36	460	166	16	22344..-K	H2344X(-HG)
200	210	411	280	230	85	610	510	130	42	35	M30	340	130	10	23044..-K	H3044X(-HG)
200	210	411	280	230	85	610	510	130	42	35	M30	340	130	10	230SM200-MA	–
200	220	434	290	240	90	640	540	140	42	35	M30	370	140	12	23144..-K	H3144X(-HG)
200	220	434	290	240	90	640	540	140	42	35	M30	370	140	12	231SM200-MA¹⁾	–
200	240	474	310	260	95	700	600	150	42	35	M30	400	164	12	23244..-K	H2344X(-HG)
220	260	516	320	280	100	770	650	160	50	42	M36	440	164	13	22248..-K	H3148X(-HG)
220	300	591	350	310	110	830	710	190	50	42	M36	500	180	22	22348..-K	H2348X(-HG)
220	220	434	290	240	90	640	540	140	42	35	M30	360	140	12	23048..-K	H3048(-HG)
220	220	434	290	240	90	640	540	140	42	35	M30	360	140	12	230SM220-MA¹⁾	–
220	240	474	310	260	95	700	600	150	42	35	M30	400	148	12	23148..-K	H3148X(-HG)
220	240	474	310	260	95	700	600	150	42	35	M30	400	148	12	231SM220-MA	–
220	260	516	320	280	100	770	650	160	50	42	M36	440	180	13	23248..-K	H2348X(-HG)
240	300	591	350	310	110	830	710	190	50	42	M36	480	181	22	22252..-K	H3152X(-HG)
240	320	631	370	330	115	880	750	200	50	42	M36	540	196	23	22352..-K	H2352X(-HG)
240	240	474	310	260	95	700	600	150	42	35	M30	400	148	12	23052..-K	H3052X(-HG)
240	240	474	310	260	95	700	600	150	42	35	M30	400	148	12	230SM240-MA	–
240	260	516	320	280	100	770	650	160	50	42	M36	440	164	13	23152..-K	H3152X(-HG)
240	260	516	320	280	100	770	650	160	50	42	M36	440	164	13	231SM240-MA¹⁾	–
240	300	591	350	310	110	830	710	190	50	42	M36	480	194	22	23252..-K	H2352X(-HG)

① Locating bearing; ② Non-locating bearing

1) Split bearing in associated housing has restricted usability. Please ask for further information.

2) Alternatively also available with split labyrinth seal NTSG.

3) With NTSG: width g_L increased by 16 mm.

4) With NTSG: width g_{LD} increased by 8 mm.

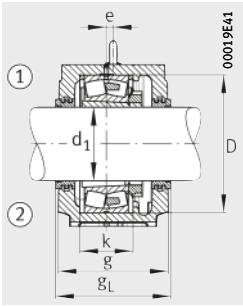

Labyrinth seal NTS

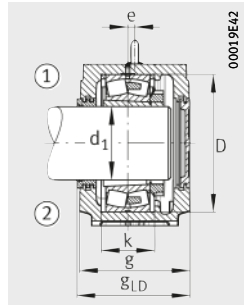

Labyrinth seal NTS
Cover NDK

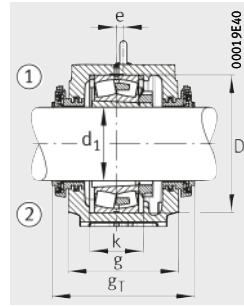

Taconite seal NTC

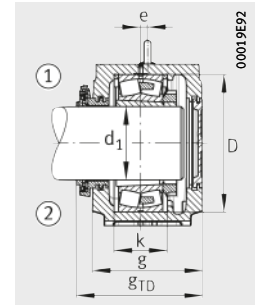

Taconite seal NTC
Cover NDK



									Housing			
Locating ring		Labyrinth seal			Taconite seal			Cover	G	Mass m ≈ kg	Designation	
	Quantity		g _L mm	g _{LD} mm		g _T mm	g _{TD} mm					
NFR360/21	2	NTS48/180	301	295,5	NTC48/180	380	335	NDK48	M20	148	SNS3048-H-D	
NFR420/14	2	NTS56/180	331	325,5	NTC56/180	411	365	NDK56	M24	249	SNS3056-H-D	
NFR310/10	4	NTS40 ²⁾	271 ³⁾	265,5 ⁴⁾	NTC40	326	293	NDK40	M20	105	SNS3040-H-D	
NFR310/10	4	NTS40 ²⁾	271 ³⁾	265,5 ⁴⁾	NTC40	326	293	NDK40	M20	105	SNS3040-H-D	
NFR340/10	2	NTS40 ²⁾	291 ³⁾	285,5 ⁴⁾	NTC40	354	317	NDK40	M20	133	SNS3140-H-D	
NFR340/10	2	NTS40 ²⁾	291 ³⁾	285,5 ⁴⁾	NTC40	354	317	NDK40	M20	133	SNS3140-H-D	
NFR360/6	2	NTS48/180	301	295,5	NTC48/180	381	335	NDK48	M20	148	SNS3240-H-D	
NFR400/10	4	NTS48/200	321	315,5	NTC48/200	400	355	NDK48	M24	184	SNS3148-H-D	
NFR460/10,5	2	NTS56/200	331	325,5	NTC56/200	411	365	NDK56	M24	264	SNS3156-H-D	
NFR340/10	4	NTS44 ²⁾	291 ³⁾	285,5 ⁴⁾	NTC44	370	325	NDK44	M20	129	SNS3044-H-D	
NFR340/10	4	NTS44 ²⁾	291 ³⁾	285,5 ⁴⁾	NTC44	370	325	NDK44	M20	129	SNS3044-H-D	
NFR370/10	2	NTS44 ²⁾	301 ³⁾	295,5 ⁴⁾	NTC44	380	335	NDK44	M20	146	SNS3144-H-D	
NFR370/10	2	NTS44 ²⁾	301 ³⁾	295,5 ⁴⁾	NTC44	380	335	NDK44	M20	146	SNS3144-H-D	
NFR400/10	2	NTS48/200	321	315,5	NTC48/200	401	355	NDK48	M24	183	SNS3244-H-D	
NFR440/22	2	NTS52/220	331	325,5	NTC52/220	410	365	NDK52	M24	238	SNS3152-H-D	
NFR500/12,5	2	NTS60/220	361	355,5	NTC60/220	441	395	NDK60	M30	317	SNS3160-H-D	
NFR360/12	4	NTS48 ²⁾	301 ³⁾	295,5 ⁴⁾	NTC48	380	335	NDK48	M20	148	SNS3048-H-D	
NFR360/12	4	NTS48 ²⁾	301 ³⁾	295,5 ⁴⁾	NTC48	380	335	NDK48	M20	148	SNS3048-H-D	
NFR400/10	2	NTS48 ²⁾	321 ³⁾	315,5 ⁴⁾	NTC48	400	355	NDK48	M24	184	SNS3148-H-D	
NFR400/10	2	NTS48 ²⁾	321 ³⁾	315,5 ⁴⁾	NTC48	400	355	NDK48	M24	184	SNS3148-H-D	
NFR440/10	2	NTS52/220	331	325,5	NTC52/220	410	365	NDK52	M24	235	SNS3248-H-D	
NFR480/25,5	2	NTS64/240	361	355,5	NTC64/240	440	395	NDK64	M30	332	SNS3064-H-D	
NFR540/15,5	2	NTS64/240	381	375,5	NTC64/240	460	415	NDK64	M30	368	SNS3164-H-D	
NFR400/22	2	NTS52 ²⁾	321 ³⁾	315,5 ⁴⁾	NTC52	401	355	NDK52	M24	180	SNS3052-H-D	
NFR400/22	2	NTS52 ²⁾	321 ³⁾	315,5 ⁴⁾	NTC52	401	355	NDK52	M24	180	SNS3052-H-D	
NFR440/10	2	NTS52 ²⁾	331 ³⁾	325,5 ⁴⁾	NTC52	410	365	NDK52	M24	238	SNS3152-H-D	
NFR440/10	2	NTS52 ²⁾	331 ³⁾	325,5 ⁴⁾	NTC52	410	365	NDK52	M24	238	SNS3152-H-D	
NFR480/10	2	NTS64/240	361	355,5	NTC64/240	440	395	NDK64	M30	331	SNS3252-H-D	

Plummer block housings

SNS, split
 For spherical roller bearings with tapered bore and adapter sleeve
 Metric shaft

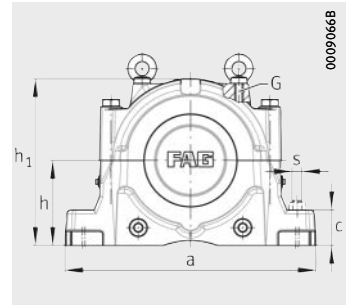
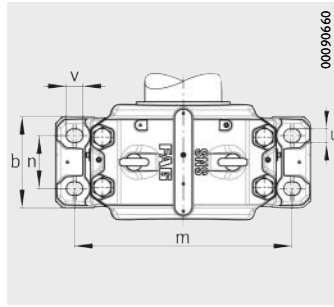

Dimension table (continued) · Dimensions in mm

Shaft d ₁	Housing Dimensions															Spherical roller bearing and accessories	
	h	h ₁	g	b	c	a	m	n	v	u	s	D	k	e	Bearing	Adapter sleeve	
260	300	591	350	310	110	830	710	190	50	42	M36	500	180	22	22256..-K	H3156X(-HG)	
260	340	675	400	360	120	950	810	220	50	42	M36	580	210	24	22356..-K	H2356X(-HG)	
260	260	516	320	280	100	770	650	160	50	42	M36	420	166	13	23056..-K	H3056(-HG)	
260	260	516	320	280	100	770	650	160	50	42	M36	420	166	13	230SM260-MA ¹⁾	–	
260	280	550	320	280	105	790	670	160	50	42	M36	460	166	16	23156..-K	H3156X(-HG)	
260	280	550	320	280	105	790	670	160	50	42	M36	460	166	16	231SM260-MA	–	
260	300	591	350	310	110	830	710	190	50	42	M36	500	196	22	23256..-K	H2356X(-HG)	
260	300	591	350	310	110	830	710	190	50	42	M36	500	196	22	232SM260-MA ¹⁾	–	
280	320	631	370	330	115	880	750	200	50	42	M36	540	196	23	22260..-K	H3160(-HG)	
280	280	550	320	280	105	790	670	160	50	42	M36	460	168	16	23060..-K	H3060(-HG)	
280	280	550	320	280	105	790	670	160	50	42	M36	460	168	16	230SM280-MA ¹⁾	–	
280	300	591	350	310	110	830	710	190	50	42	M36	500	180	22	23160..-K	H3160(-HG)	
280	300	591	350	310	110	830	710	190	50	42	M36	500	180	22	231SM280-MA ¹⁾	–	
280	320	631	370	330	115	880	750	200	50	42	M36	540	212	23	23260..-K	H3260(-HG)	
300	340	675	400	360	120	950	810	220	50	42	M36	580	190	24	22264..-K	H3164-HG	
300	300	591	350	310	110	830	710	190	50	42	M36	480	181	22	23064..-K	H3064-HG	
300	300	591	350	310	110	830	710	190	50	42	M36	480	181	22	230SM300-MA ¹⁾	–	
300	320	631	370	330	115	880	750	200	50	42	M36	540	196	23	23164..-K	H3164-HG	
300	320	631	370	330	115	880	750	200	50	42	M36	540	196	23	231SM300-MA ¹⁾	–	
300	340	675	400	360	120	950	810	220	50	42	M36	580	228	24	23264..-K	H3264-HG	
300	340	675	400	360	120	950	810	220	50	42	M36	580	228	24	232SM300-MA ¹⁾	–	
320	320	631	370	330	115	880	750	200	50	42	M36	520	197	23	23068..-K	H3068-HG	
320	320	631	370	330	115	880	750	200	50	42	M36	520	197	23	230SM320-MA ¹⁾	–	
320	340	675	400	360	120	950	810	220	50	42	M36	580	210	24	23168..-K	H3168-HG	
320	340	675	400	360	120	950	810	220	50	42	M36	580	210	24	231SM320-MA	–	
320	360	715	400	360	120	1040	870	220	50	42	M36	620	244	30	23268..-K	H3268-HG	

① Locating bearing; ② Non-locating bearing

¹⁾ Split bearing in associated housing has restricted usability. Please ask for further information.

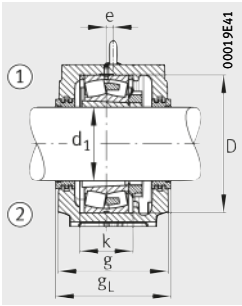

Labyrinth seal NTS

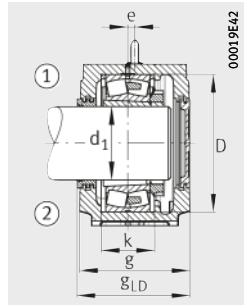

Labyrinth seal NTS
Cover NDK

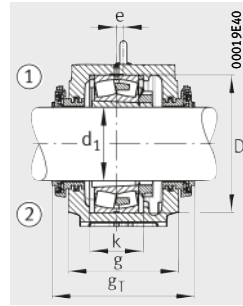

Taconite seal NTC

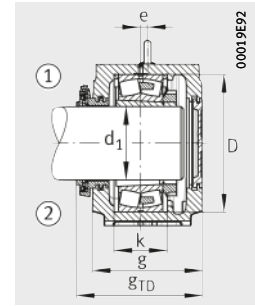

Taconite seal NTC
Cover NDK



								Housing			
Locating ring		Labyrinth seal			Taconite seal			Cover	G	Mass m ≈ kg	Designation
	Quantity		gL mm	gL _D mm		g _T mm	g _{TD} mm				
NFR500/25	2	NTS60/260	361	355,5	NTC60/260	440	395	NDK60	M30	317	SNS3160-H-D
NFR580/17,5	2	NTS68/260	411	405,5	NTC68/260	490	445	NDK68	M30	461	SNS3168-H-D
NFR420/10	6	NTS56	331	325,5	NTC56	411	365	NDK56	M24	249	SNS3056-H-D
NFR420/10	6	NTS56	331	325,5	NTC56	411	365	NDK56	M24	249	SNS3056-H-D
NFR460/10	2	NTS56	331	325,5	NTC56	410	365	NDK56	M24	264	SNS3156-H-D
NFR460/10	2	NTS56	331	325,5	NTC56	410	365	NDK56	M24	264	SNS3156-H-D
NFR500/10	2	NTS60/260	361	355,5	NTC60/260	441	395	NDK60	M30	314	SNS3256-H-D
NFR500/10	2	NTS60/260	361	355,5	NTC60/260	441	395	NDK60	M30	314	SNS3256-H-D
NFR540/28	2	NTS64/280	381	375,5	NTC64/280	460	415	NDK64	M30	368	SNS3164-H-D
NFR460/25	2	NTS60	331	325,5	NTC60	411	365	NDK60	M24	260	SNS3060-H-D
NFR460/25	2	NTS60	331	325,5	NTC60	411	365	NDK60	M24	260	SNS3060-H-D
NFR500/10	2	NTS60	361	355,5	NTC60	440	395	NDK60	M30	317	SNS3160-H-D
NFR500/10	2	NTS60	361	355,5	NTC60	440	395	NDK60	M30	317	SNS3160-H-D
NFR540/10	2	NTS64/280	381	375,5	NTC64/280	461	415	NDK64	M30	364	SNS3260-H-D
NFR580/20	2	NTS68/300	411	405,5	NTC68/300	490	445	NDK68	M30	466	SNS2264-H-D
NFR480/10	6	NTS64	361	355,5	NTC64	441	395	NDK64	M30	332	SNS3064-H-D
NFR480/10	6	NTS64	361	355,5	NTC64	441	395	NDK64	M30	332	SNS3064-H-D
NFR540/10	2	NTS64	381	375,5	NTC64	460	415	NDK64	M30	368	SNS3164-H-D
NFR540/10	2	NTS64	381	375,5	NTC64	460	415	NDK64	M30	368	SNS3164-H-D
NFR580/10	2	NTS68/300	411	405,5	NTC68/300	491	445	NDK68	M30	457	SNS3264-H-D
NFR580/10	2	NTS68/300	411	405,5	NTC68/300	491	445	NDK68	M30	457	SNS3264-H-D
NFR520/16	4	NTS68	381	375,5	NTC68	461	415	NDK68	M30	386	SNS3068-H-D
NFR520/16	4	NTS68	381	375,5	NTC68	461	415	NDK68	M30	386	SNS3068-H-D
NFR580/10	2	NTS68	411	405,5	NTC68	490	445	NDK68	M30	461	SNS3168-H-D
NFR580/10	2	NTS68	411	405,5	NTC68	490	445	NDK68	M30	461	SNS3168-H-D
NFR620/10	2	NTS76/320	411	405,5	NTC76/320	490	445	NDK76	M36	530	SNS3268-H-D

Plummer block housings

SNS, split
 For spherical roller bearings with tapered bore and adapter sleeve
 Metric shaft

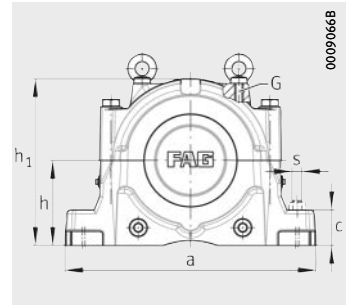
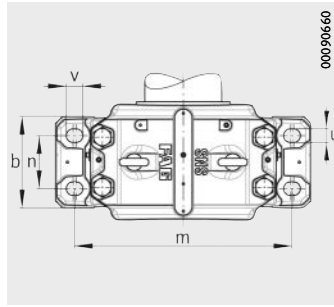

Dimension table (continued) · Dimensions in mm

Shaft d_1	Housing Dimensions															Spherical roller bearing and accessories	
	h	h_1	g	b	c	a	m	n	v	u	s	D	k	e	Bearing	Adapter sleeve	
340	380	755	430	390	125	1120	950	240	60	48	M42	650	220	30	22272...-K	H3172-HG	
340	320	631	370	330	115	880	750	200	50	42	M36	540	198	23	23072...-K	H3072-HG	
340	320	631	370	330	115	880	750	200	50	42	M36	540	198	23	230SM340-MA¹⁾	–	
340	350	695	400	360	120	1000	840	220	50	42	M36	600	212	30	23172...-K	H3172-HG	
340	350	695	400	360	120	1000	840	220	50	42	M36	600	212	30	231SM340-MA¹⁾	–	
340	380	755	430	390	125	1120	950	240	60	48	M42	650	252	30	23272...-K	H3272-HG	
340	380	755	430	390	125	1120	950	240	60	48	M42	650	252	30	232SM340-MA¹⁾	–	
360	340	675	400	360	120	950	810	220	50	42	M36	560	180	24	23076...-K	H3076-HG	
360	340	675	400	360	120	950	810	220	50	42	M36	560	180	24	230SM360-MA	–	
360	360	715	400	360	120	1040	870	220	50	42	M36	620	214	30	23176...-K	H3176-HG	
360	360	715	400	360	120	1040	870	220	50	42	M36	620	214	30	231SM360-MA¹⁾	–	
360	410	810	460	420	130	1170	1000	260	60	48	M42	680	260	35	23276...-K	H3276-HG	
380	350	695	400	360	120	1000	840	220	50	42	M36	600	192	30	23080...-K	H3080-HG	
380	350	695	400	360	120	1000	840	220	50	42	M36	600	192	30	230SM380-MA¹⁾	–	
380	380	755	430	390	125	1120	950	240	60	48	M42	650	220	30	23180...-K	H3180-HG	
380	380	755	430	390	125	1120	950	240	60	48	M42	650	220	30	231SM380-MA¹⁾	–	
380	420	835	460	430	135	1220	1030	260	60	48	M42	720	276	35	23280...-K	H3280-HG	
400	360	715	400	360	120	1040	870	220	50	42	M36	620	194	30	23084...-K	H3084X-HG	
400	360	715	400	360	120	1040	870	220	50	42	M36	620	194	30	230SM400-MA¹⁾	–	
400	410	810	460	420	130	1170	1000	260	60	48	M42	700	244	35	23184...-K	H3184-HG	
400	410	810	460	420	130	1170	1000	260	60	48	M42	700	244	35	231SM400-MA	–	
400	440	880	470	440	145	1280	1070	260	60	48	M42	760	292	35	23284...-K	H3284-HG	

① Locating bearing; ② Non-locating bearing

¹⁾ Split bearing in associated housing has restricted usability. Please ask for further information.

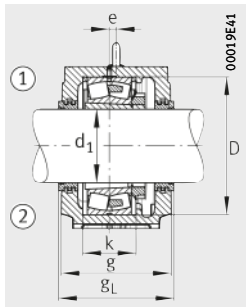

Labyrinth seal NTS

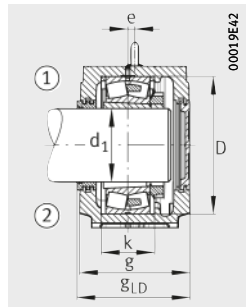

Labyrinth seal NTS
Cover NDK

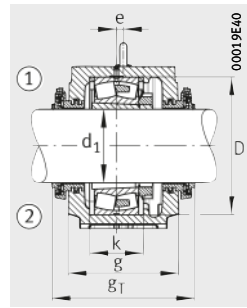

Taconite seal NTC

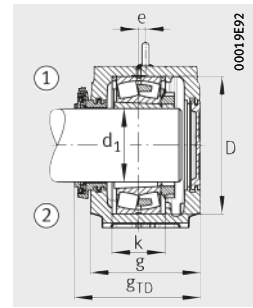

Taconite seal NTC
Cover NDK



								Housing			
Locating ring		Labyrinth seal			Taconite seal			Cover	G	Mass m ≈ kg	Designation
	Quantity		g _L mm	g _{LD} mm		g _T mm	g _{TD} mm				
NFR650/25	2	NTS80/340	441	435,5	NTC80/340	520	475	NDK80	M42	681	SNS3180-H-D
NFR540/16	4	NTS72	381	375,5	NTC72	461	415	NDK72	M30	356	SNS3072-H-D
NFR540/16	4	NTS72	381	375,5	NTC72	461	415	NDK72	M30	356	SNS3072-H-D
NFR600/10	2	NTS72	411	405,5	NTC72	490	445	NDK72	M36	498	SNS3172-H-D
NFR600/10	2	NTS72	411	405,5	NTC72	490	445	NDK72	M36	498	SNS3172-H-D
NFR650/10	2	NTS80/340	441	435,5	NTC80/340	520	475	NDK80	M42	675	SNS3272-H-D
NFR650/10	2	NTS80/340	441	435,5	NTC80/340	520	475	NDK80	M42	675	SNS3272-H-D
NFR560/22,5	2	NTS76	411	405,5	NTC76	491	445	NDK76	M30	481	SNS3076-H-D
NFR560/22,5	2	NTS76	411	405,5	NTC76	491	445	NDK76	M30	481	SNS3076-H-D
NFR620/10	2	NTS76	411	405,5	NTC76	490	445	NDK76	M36	534	SNS3176-H-D
NFR620/10	2	NTS76	411	405,5	NTC76	490	445	NDK76	M36	534	SNS3176-H-D
NFR680/10	2	NTS92/360	471	465,5	NTC92/360	550	505	NDK92	M42	841	SNS3276-H-D
NFR600/22	2	NTS80	411	405,5	NTC80	491	445	NDK80	M36	489	SNS3080-H-D
NFR600/22	2	NTS80	411	405,5	NTC80	491	445	NDK80	M36	489	SNS3080-H-D
NFR650/10	2	NTS80	441	435,5	NTC80	520	475	NDK80	M42	681	SNS3180-H-D
NFR650/10	2	NTS80	441	435,5	NTC80	520	475	NDK80	M42	681	SNS3180-H-D
NFR720/10	2	NTS88/380	471	465,5	NTC88/380	550	505	NDK88	M42	895	SNS3280-H-D
NFR620/22	2	NTS84	411	405,5	NTC84	491	445	NDK84	M36	527	SNS3084-H-D
NFR620/22	2	NTS84	411	405,5	NTC84	491	445	NDK84	M36	527	SNS3084-H-D
NFR700/10	2	NTS84	471	465,5	NTC84	550	505	NDK84	M42	821	SNS3184-H-D
NFR700/10	2	NTS84	471	465,5	NTC84	550	505	NDK84	M42	821	SNS3184-H-D
NFR760/10	2	NTS92/400	481	475,5	NTC92/400	560	515	NDK92	M48	984	SNS3284-H-D

Plummer block housings

SNS, split
 For spherical roller bearings with tapered bore and adapter sleeve
 Metric shaft

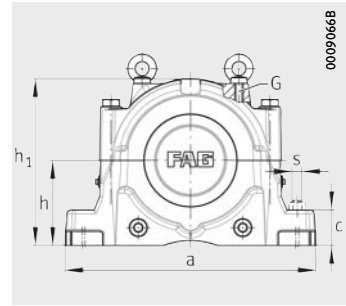
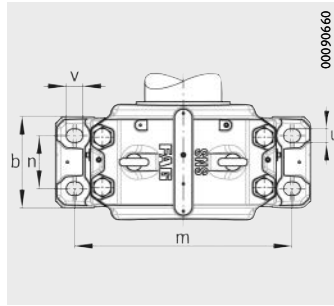

Dimension table (continued) · Dimensions in mm

Shaft d_1	Housing Dimensions														Spherical roller bearing and accessories	
	h	h_1	g	b	c	a	m	n	v	u	s	D	k	e	Bearing	Adapter sleeve
410	380	755	430	390	125	1120	950	240	60	48	M42	650	200	30	23088..-K	H3088-HG
410	380	755	430	390	125	1120	950	240	60	48	M42	650	200	30	230SM410-MA	–
410	420	835	460	430	135	1220	1030	260	60	48	M42	720	246	35	23188..-K	H3188-HG
410	420	835	460	430	135	1220	1030	260	60	48	M42	720	246	35	231SM410-MA¹⁾	–
410	460	920	470	440	155	1330	1110	260	70	56	M48	790	300	35	23288..-K	H3288-HG
430	410	810	460	420	130	1170	1000	260	60	48	M42	680	224	35	23092..-K	H3092-HG
430	440	880	470	440	145	1280	1070	260	60	48	M42	760	260	35	23192..-K	H3192-HG
450	410	810	460	420	130	1170	1000	260	60	48	M42	700	224	35	23096..-K	H3096-HG
450	460	920	470	440	155	1330	1110	260	70	56	M48	790	268	35	23196..-K	H3196-HG
470	420	835	460	430	135	1220	1030	260	60	48	M42	720	226	35	230/500..-K	H30/500-HG
500	460	920	470	440	155	1330	1110	260	70	56	M48	780	248	35	230/530..-K	H30/530-HG

① Locating bearing; ② Non-locating bearing

¹⁾ Split bearing in associated housing has restricted usability. Please ask for further information.

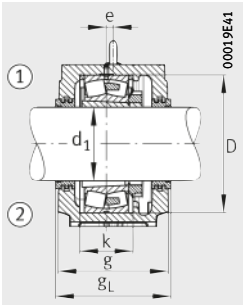

Labyrinth seal NTS

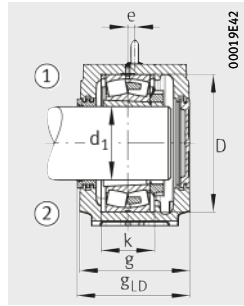

Labyrinth seal NTS
Cover NDK

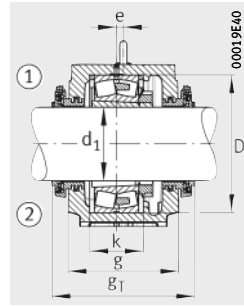

Taconite seal NTC

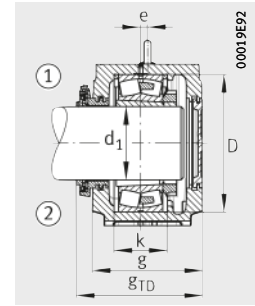

Taconite seal NTC
Cover NDK



									Housing		
Locating ring		Labyrinth seal			Taconite seal			Cover	G	Mass m ≈ kg	Designation
	Quantity		gL mm	gL _D mm		g _T mm	g _{TD} mm				
NFR650/21,5	2	NTS88	441	435,5	NTC88	521	475	NDK88	M42	672	SNS3088-H-D
NFR650/21,5	2	NTS88	441	435,5	NTC88	521	475	NDK88	M42	672	SNS3088-H-D
NFR720/10	2	NTS88	471	465,5	NTC88	550	505	NDK88	M42	895	SNS3188-H-D
NFR720/10	2	NTS88	471	465,5	NTC88	550	505	NDK88	M42	895	SNS3188-H-D
NFR790/10	2	NTS96/410	481	475,5	NTC96/410	560	515	NDK96	M48	1 100	SNS3288-H-D
NFR680/30,5	2	NTS92	471	465,5	NTC92	551	505	NDK92	M42	849	SNS3092-H-D
NFR760/10	2	NTS92	481	475,5	NTC92	560	515	NDK92	M48	993	SNS3192-H-D
NFR700/29,5	2	NTS96	471	465,5	NTC96	551	505	NDK96	M42	806	SNS3096-H-D
NFR790/10	2	NTS96	481	475,5	NTC96	560	515	NDK96	M48	1 100	SNS3196-H-D
NFR720/29,5	2	NTS500	471	465,5	NTC500	551	505	NDK500	M42	895	SNS30/500-H-D
NFR780/31,5	2	NTS530	481	475,5	NTC530	561	515	NDK530	M48	1 100	SNS30/530-H-D

Plummer block housings

SNS, split
For spherical roller bearings with cylindrical bore
Metric shaft

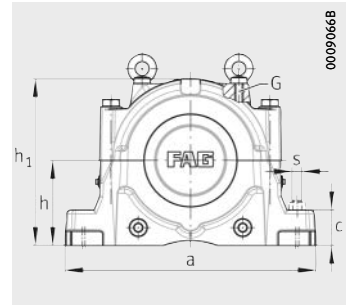
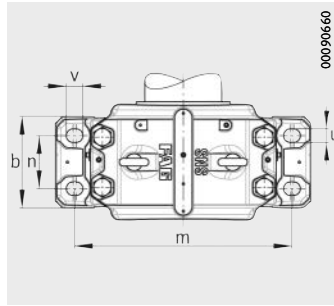

Dimension table - Dimensions in mm

Shaft		Housing Dimensions													Spherical roller bearing and accessories	
d	d ₂	h	h ₁	g	b	c	a	m	n	v	u	s	D	k	e	Bearing
130	150	170	333	230	180	70	510	430	100	34	28	M24	280	108	14	22 326
140	160	180	353	240	190	75	530	450	110	34	28	M24	300	116	15	22 328
150	170	190	375	260	210	80	560	480	120	34	28	M24	320	124	10	22 330
160	180	180	353	240	190	75	530	450	110	34	28	M24	290	115	15	22 232
160	180	210	411	280	230	85	610	510	130	42	35	M30	340	132	10	22 332
160	180	180	353	240	190	75	530	450	110	34	28	M24	290	115	15	23 232
170	190	190	375	260	210	80	560	480	120	34	28	M24	310	122	10	22 234
170	190	220	434	290	240	90	640	540	140	42	35	M30	360	140	12	22 334
170	180	170	333	230	180	70	510	430	100	34	28	M24	280	108	14	23 134
170	190	190	375	260	210	80	560	480	120	34	28	M24	310	122	10	23 234
180	200	190	375	260	210	80	560	480	120	34	28	M24	320	124	10	22 236
180	200	170	333	230	180	70	510	430	100	34	28	M24	280	108	14	23 036
180	200	180	353	240	190	75	530	450	110	34	28	M24	300	116	15	23 136
180	200	190	375	260	210	80	560	480	120	34	28	M24	320	124	10	23 236
180	200	170	333	230	180	70	510	430	100	34	28	M24	280	108	14	24 036
190	210	210	411	280	230	85	610	510	130	42	35	M30	340	132	10	22 238
190	210	240	474	310	260	95	700	600	150	42	35	M30	400	148	12	22 338
190	200	180	353	240	190	75	530	450	110	34	28	M24	290	115	15	23 038
190	200	190	375	260	210	80	560	480	120	34	28	M24	320	124	10	23 138
190	210	210	411	280	230	85	610	510	130	42	35	M30	340	132	10	23 238
190	200	180	353	240	190	75	530	450	110	34	28	M24	290	115	15	24 038
200	220	220	434	290	240	90	640	540	140	42	35	M30	360	140	12	22 240
200	220	190	375	260	210	80	560	480	120	34	28	M24	310	122	10	23 040
200	220	210	411	280	230	85	610	510	130	42	35	M30	340	132	10	23 140
200	220	220	434	290	240	90	640	540	140	42	35	M30	360	140	12	23 240
200	220	190	375	260	210	80	560	480	120	34	28	M24	310	122	10	24 040

① Locating bearing; ② Non-locating bearing

1) Alternatively also available with split labyrinth seal NTSG.

2) With NTSG: width g_L increased by 16 mm.

3) With NTSG: width g_{LD} increased by 8 mm.

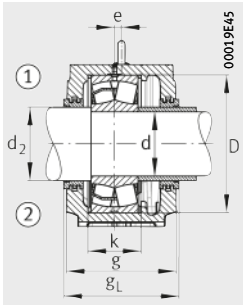

Labyrinth seal NTS

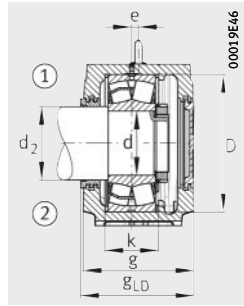

Labyrinth seal NTS
Cover NDK

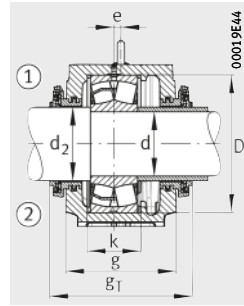

Taconite seal NTC

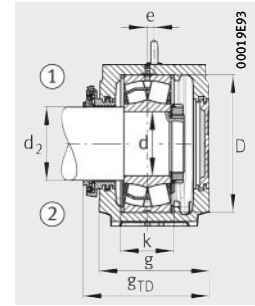

Taconite seal NTC
Cover NDK



									Housing		
Locating ring		Labyrinth seal			Taconite seal			Cover	G	Mass m ≈ kg	Designation
	Quantity		g _L mm	g _{LD} mm		g _T mm	g _{TD} mm				
NFR280/7,5	2	NTS34 ¹⁾	241 ²⁾	235,5 ³⁾	NTC34	299	264,5	NDK34	M16	75	SNS3134-H-D
NFR300/7	2	NTS36 ¹⁾	251 ²⁾	245,5 ³⁾	NTC36	314	277	NDK36	M16	83	SNS3136-H-D
NFR320/8	2	NTS38 ¹⁾	271 ²⁾	265,5 ³⁾	NTC38	334	297	NDK38	M20	102	SNS3138-H-D
NFR290/17,5	2	NTS38/180	251	245,5	NTC38/180	314	277	NDK38	M16	86	SNS3038-H-D
NFR340/9	2	NTS40 ¹⁾	291 ²⁾	285,5 ³⁾	NTC40	354	317	NDK40	M20	133	SNS3140-H-D
NFR290/5,5	2	NTS38/180	251	245,5	NTC38/180	314	277	NDK38	M16	86	SNS3038-H-D
NFR310/18	2	NTS40/190	271	265,5	NTC40/190	334	297	NDK40	M20	105	SNS3040-H-D
NFR360/10	2	NTS48/190	301	295,5	NTC48/190	380	335	NDK48	M20	148	SNS3048-H-D
NFR280/10	2	NTS40 ¹⁾	241 ²⁾	235,5 ³⁾	NTC40	298	264	NDK40	M16	71	SNS3134-Z-D
NFR310/6	2	NTS40/190	271	265,5	NTC40/190	326	293	NDK40	M20	105	SNS3234-Z-D
NFR320/19	2	NTS44 ¹⁾	271 ²⁾	265,5 ³⁾	NTC44	350	305	NDK44	M20	97	SNS3138-Z-D
NFR280/17	2	NTS44 ¹⁾	241 ²⁾	235,5 ³⁾	NTC44	320	275	NDK44	M16	67	SNS3036-Z-D
NFR300/10	2	NTS44 ¹⁾	251 ²⁾	245,5 ³⁾	NTC44	330	285	NDK44	M16	77	SNS3136-Z-D
NFR320/6	2	NTS44 ¹⁾	271 ²⁾	265,5 ³⁾	NTC44	350	305	NDK44	M20	97	SNS3236-Z-D
NFR280/4	2	NTS44 ¹⁾	241 ²⁾	235,5 ³⁾	NTC44	320	275	NDK44	M16	67	SNS3036-Z-D
NFR340/10	4	NTS48/210	291	285,5	NTC48/210	372	302,5	NDK48	M20	125	SNS3140-Z-D
NFR400/8	2	NTS48/210	321	315,5	NTC48/210	402	329,5	NDK48	M24	184	SNS3148-H-D
NFR290/10	4	NTS44 ¹⁾	251 ²⁾	245,5 ³⁾	NTC44	330	285	NDK44	M16	81	SNS3038-Z-D
NFR320/10	2	NTS44 ¹⁾	271 ²⁾	265,5 ³⁾	NTC44	350	305	NDK44	M20	97	SNS3138-Z-D
NFR340/6	2	NTS48/210	291	285,5	NTC48/210	372	302,5	NDK48	M20	125	SNS3238-Z-D
NFR290/7,5	2	NTS44 ¹⁾	251 ²⁾	245,5 ³⁾	NTC44	330	285	NDK44	M16	81	SNS3038-Z-D
NFR360/21	2	NTS48 ¹⁾	301 ²⁾	295,5 ³⁾	NTC48	380	335	NDK48	M20	148	SNS3048-H-D
NFR310/10	4	NTS48 ¹⁾	271 ²⁾	265,5 ³⁾	NTC48	350	305	NDK48	M20	97	SNS3040-Z-D
NFR340/10	2	NTS48 ¹⁾	291 ²⁾	285,5 ³⁾	NTC48	372	302,5	NDK48	M20	125	SNS3140-Z-D
NFR360/6	2	NTS48 ¹⁾	301 ²⁾	295,5 ³⁾	NTC48	380	335	NDK48	M20	148	SNS3240-Z-D
NFR310/6,5	2	NTS48 ¹⁾	271 ²⁾	265,5 ³⁾	NTC48	350	305	NDK48	M20	97	SNS3040-Z-D

Plummer block housings

SNS, split
For spherical roller bearings with cylindrical bore
Metric shaft

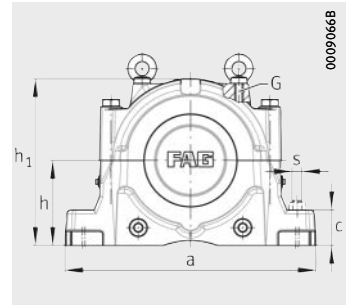
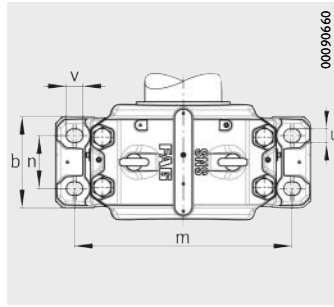

Dimension table (continued) · Dimensions in mm

Shaft		Housing Dimensions													Spherical roller bearing and accessories	
d	d ₂	h	h ₁	g	b	c	a	m	n	v	u	s	D	k	e	Bearing
220	240	240	474	310	260	95	700	600	150	42	35	M30	400	148	12	22 244
220	240	280	550	320	280	105	790	670	160	50	42	M36	460	166	16	22 344
220	240	210	411	280	230	85	610	510	130	42	35	M30	340	130	10	23 044
220	240	220	434	290	240	90	640	540	140	42	35	M30	370	140	12	23 144
220	240	240	474	310	260	95	700	600	150	42	35	M30	400	164	12	23 244
220	240	210	411	280	230	85	610	510	130	42	35	M30	340	130	10	24 044
240	260	260	516	320	280	100	770	650	160	50	42	M36	440	164	13	22 248
240	260	300	591	350	310	110	830	710	190	50	42	M36	500	180	22	22 348
240	260	220	434	290	240	90	640	540	140	42	35	M30	360	140	12	23 048
240	260	240	474	310	260	95	700	600	150	42	35	M30	400	148	12	23 148
240	260	260	516	320	280	100	770	650	160	50	42	M36	440	180	13	23 248
240	260	220	434	290	240	90	640	540	140	42	35	M30	360	140	12	24 048
260	280	300	591	350	310	110	830	710	190	50	42	M36	480	181	22	22 252
260	290	320	631	370	330	115	880	750	200	50	42	M36	540	196	23	22 352
260	280	240	474	310	260	95	700	600	150	42	35	M30	400	148	12	23 052
260	280	260	516	320	280	100	770	650	160	50	42	M36	440	164	13	23 152
260	280	300	591	350	310	110	830	710	190	50	42	M36	480	194	22	23 252
260	280	240	474	310	260	95	700	600	150	42	35	M30	400	148	12	24 052
280	300	300	591	350	310	110	830	710	190	50	42	M36	500	180	22	22 256
280	310	340	675	400	360	120	950	810	220	50	42	M36	580	210	24	22 356
280	300	260	516	320	280	100	770	650	160	50	42	M36	420	166	13	23 056
280	300	280	550	320	280	105	790	670	160	50	42	M36	460	166	16	23 156
280	300	300	591	350	310	110	830	710	190	50	42	M36	500	196	22	23 256
280	300	260	516	320	280	100	770	650	160	50	42	M36	420	166	13	24 056

① Locating bearing; ② Non-locating bearing

¹⁾ Alternatively also available with split labyrinth seal NTSG.

²⁾ With NTSG: width g_L increased by 16 mm.

³⁾ With NTSG: width g_{LD} increased by 8 mm.

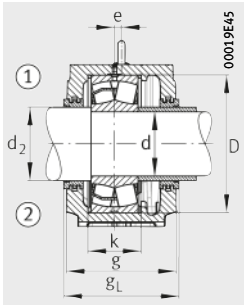

Labyrinth seal NTS

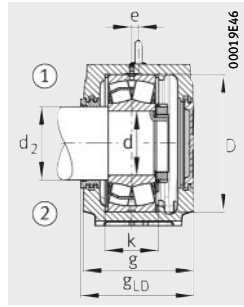

Labyrinth seal NTS
Cover NDK

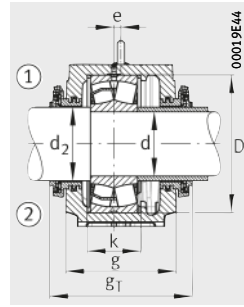

Taconite seal NTC

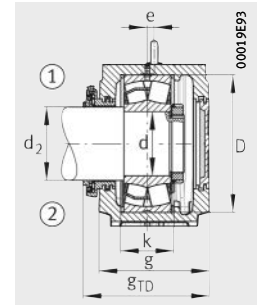

Taconite seal NTC
Cover NDK



									Housing		
Locating ring		Labyrinth seal			Taconite seal			Cover	G	Mass m ≈ kg	Designation
	Quantity		g _L mm	g _{LD} mm		g _T mm	g _{TD} mm				
NFR400/10	4	NTS56/240	321	315,5	NTC56/240	400	355	NDK56	M24	176	SNS3148-Z-D
NFR460/10,5	2	NTS56/240	331	325,5	NTC56/240	410	365	NDK56	M24	264	SNS3156-H-D
NFR340/10	4	NTS52 ¹⁾	291 ²⁾	285,5 ³⁾	NTC52	370	325	NDK52	M20	121	SNS3044-Z-D
NFR370/10	2	NTS52 ¹⁾	301 ²⁾	295,5 ³⁾	NTC52	380	335	NDK52	M20	138	SNS3144-Z-D
NFR400/10	2	NTS56/240	321	315,5	NTC56/240	400	355	NDK56	M24	174	SNS3244-Z-D
NFR340/6	2	NTS52 ¹⁾	291 ²⁾	285,5 ³⁾	NTC52	370	325	NDK52	M20	121	SNS3044-Z-D
NFR440/22	2	NTS60/260	331	325,5	NTC60/260	410	365	NDK60	M24	229	SNS3152-Z-D
NFR500/12,5	2	NTS60/260	361	355,5	NTC60/260	440	395	NDK60	M30	317	SNS3160-H-D
NFR360/12	4	NTS56	301	295,5	NTC56	380	335	NDK56	M20	140	SNS3048-Z-D
NFR400/10	2	NTS56	321	315,5	NTC56	400	355	NDK56	M24	176	SNS3148-Z-D
NFR440/10	2	NTS60/260	331	325,5	NTC60/260	410	365	NDK60	M24	226	SNS3248-Z-D
NFR360/11	2	NTS56	301	295,5	NTC56	380	335	NDK56	M20	140	SNS3048-Z-D
NFR480/25,5	2	NTS64/280	361	355,5	NTC64/280	440	395	NDK64	M30	332	SNS3064-H-D
NFR540/15,5	2	NTS64/290	381	375,5	NTC64/290	460	415	NDK64	M30	368	SNS3164-H-D
NFR400/22	2	NTS60	321	315,5	NTC60	400	355	NDK60	M24	171	SNS3052-Z-D
NFR440/10	2	NTS60	331	325,5	NTC60	410	365	NDK60	M24	229	SNS3152-Z-D
NFR480/10	2	NTS64/280	361	355,5	NTC64/280	440	395	NDK64	M30	331	SNS3252-Z-D
NFR400/4	2	NTS60	321	315,5	NTC60	400	355	NDK60	M24	171	SNS3052-Z-D
NFR500/25	2	NTS68/300	361	355,5	NTC68/300	440	395	NDK68	M30	307	SNS3160-Z-D
NFR580/17,5	2	NTS68/310	411	405,5	NTC68/310	490	445	NDK68	M30	461	SNS3168-H-D
NFR420/10	6	NTS64	331	325,5	NTC64	410	365	NDK64	M24	240	SNS3056-Z-D
NFR460/10	2	NTS64	331	325,5	NTC64	410	365	NDK64	M24	255	SNS3156-Z-D
NFR500/10	2	NTS68/300	361	355,5	NTC68/300	440	395	NDK68	300	591	SNS3256-Z-D
NFR420/13	2	NTS64	331	325,5	NTC64	410	365	NDK64	M24	240	SNS3056-Z-D

Plummer block housings

SNS, split
For spherical roller bearings with cylindrical bore
Metric shaft

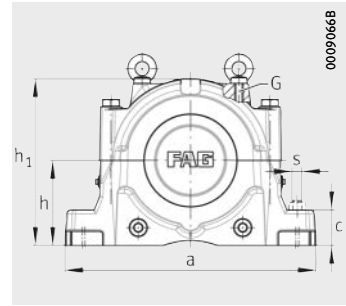
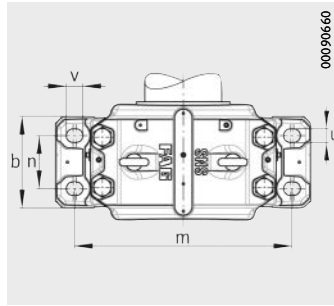

Dimension table (continued) · Dimensions in mm

Shaft		Housing Dimensions														Spherical roller bearing and accessories
d	d ₂	h	h ₁	g	b	c	a	m	n	v	u	s	D	k	e	Bearing
300	320	320	631	370	330	115	880	750	200	50	42	M36	540	196	23	22 260
300	320	280	550	320	280	105	790	670	160	50	42	M36	460	168	16	23 060
300	320	300	591	350	310	110	830	710	190	50	42	M36	500	180	22	23 160
300	320	320	631	370	330	115	880	750	200	50	42	M36	540	212	23	23 260
300	320	280	550	320	280	105	790	670	160	50	42	M36	460	168	16	24 060
320	340	340	675	400	360	120	950	810	220	50	42	M36	580	190	24	22 264
320	340	300	591	350	310	110	830	710	190	50	42	M36	480	181	22	23 064
320	340	320	631	370	330	115	880	750	200	50	42	M36	540	196	23	23 164
320	340	340	675	400	360	120	950	810	220	50	42	M36	580	228	24	23 264
320	340	300	591	350	310	110	830	710	190	50	42	M36	480	181	22	24 064
340	360	320	631	370	330	115	880	750	200	50	42	M36	520	197	23	23 068
340	360	340	675	400	360	120	950	810	220	50	42	M36	580	210	24	23 168
340	370	360	715	400	360	120	1040	870	220	50	42	M36	620	244	30	23 268
340	360	320	631	370	330	115	880	750	200	50	42	M36	520	197	23	24 068
360	390	380	755	430	390	125	1120	950	240	60	48	M42	650	220	30	22 272
360	380	320	631	370	330	115	880	750	200	50	42	M36	540	198	23	23 072
360	380	350	695	400	360	120	1000	840	220	50	42	M36	600	212	30	23 172
360	390	380	755	430	390	125	1120	950	240	60	48	M42	650	252	30	23 272
360	380	320	631	370	330	115	880	750	200	50	42	M36	540	198	23	24 072
380	400	340	675	400	360	120	950	810	220	50	42	M36	560	180	24	23 076
380	400	360	715	400	360	120	1040	870	220	50	42	M36	620	214	30	23 176
380	410	410	810	460	420	130	1170	1000	260	60	48	M42	680	260	35	23 276
380	400	340	675	400	360	120	950	810	220	50	42	M36	560	200	24	24 076

① Locating bearing; ② Non-locating bearing

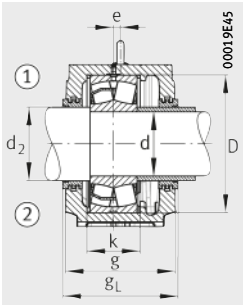

Labyrinth seal NTS

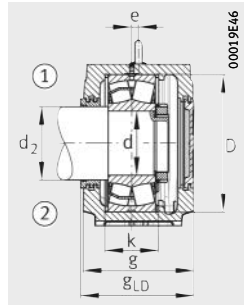

Labyrinth seal NTS
Cover NDK

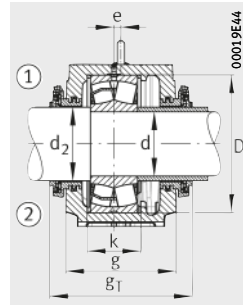

Taconite seal NTC

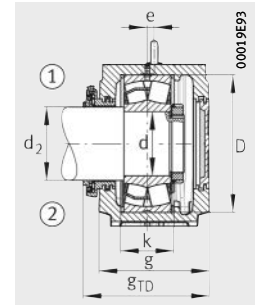

Taconite seal NTC
Cover NDK



								Housing			
Locating ring		Labyrinth seal			Taconite seal			Cover	G	Mass m ≈ kg	Designation
	Quantity		g _L mm	g _{LD} mm		g _T mm	g _{TD} mm				
NFR540/28	2	NTS72/320	381	375,5	NTC72/320	460	415	NDK72	M30	357	SNS3164-Z-D
NFR460/25	2	NTS68	331	325,5	NTC68	410	365	NDK68	M24	249	SNS3060-Z-D
NFR500/10	2	NTS68	361	355,5	NTC68	440	395	NDK68	M30	307	SNS3160-Z-D
NFR540/10	2	NTS72/320	381	375,5	NTC72/320	460	415	NDK72	M30	353	SNS3260-Z-D
NFR460/4	2	NTS68	331	325,5	NTC68	410	365	NDK68	M24	249	SNS3060-Z-D
NFR580/20	2	NTS76/340	411	405,5	NTC76/340	490	445	NDK76	M30	455	SNS2264-Z-D
NFR480/10	6	NTS72	361	355,5	NTC72	440	395	NDK72	M30	321	SNS3064-Z-D
NFR540/10	2	NTS72	381	375,5	NTC72	460	415	NDK72	M30	357	SNS3164-Z-D
NFR580/10	2	NTS76/340	411	405,5	NTC76/340	490	445	NDK76	M30	445	SNS3264-Z-D
NFR480/10,5	2	NTS72	361	355,5	NTC72	440	395	NDK72	M30	321	SNS3064-Z-D
NFR520/16	4	NTS76	381	375,5	NTC76	460	415	NDK76	M30	374	SNS3068-Z-D
NFR580/10	2	NTS76	411	405,5	NTC76	490	445	NDK76	M30	450	SNS3168-Z-D
NFR620/10	2	NTS76/370	411	405,5	NTC76/370	490	445	NDK76	M36	530	SNS3268-Z-D
NFR520/8,5	2	NTS76	381	375,5	NTC76	460	415	NDK76	M30	374	SNS3068-Z-D
NFR650/25	2	NTS80/390	441	435,5	NTC80/390	520	475	NDK80	M42	681	SNS3180-H-D
NFR540/16	4	NTS80	381	375,5	NTC80	460	415	NDK80	M30	344	SNS3072-Z-D
NFR600/10	2	NTS80	411	405,5	NTC80	490	445	NDK80	M36	486	SNS3172-Z-D
NFR650/10	2	NTS80/390	441	435,5	NTC80/390	520	475	NDK80	M42	675	SNS3272-Z-D
NFR540/9	2	NTS80	381	375,5	NTC80	460	415	NDK80	M30	344	SNS3072-Z-D
NFR560/22,5	2	NTS84	411	405,5	NTC84	490	445	NDK84	M30	467	SNS3076-Z-D
NFR620/10	2	NTS84	411	405,5	NTC84	490	445	NDK84	M36	521	SNS3176-Z-D
NFR680/10	2	NTS92/410	471	465,5	NTC92/410	550	505	NDK92	M42	841	SNS3276-Z-D
NFR560/10	2	NTS84	411	405,5	NTC84	475	438	NDK84	M30	465	SNS4076-Z-D

Plummer block housings

SNS, split
For spherical roller bearings with cylindrical bore
Metric shaft

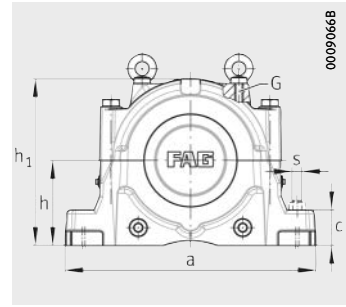
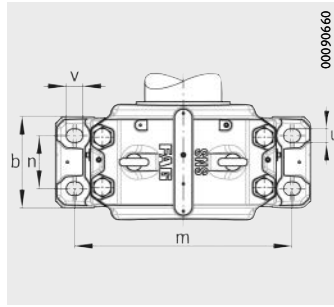

Dimension table (continued) · Dimensions in mm

Shaft		Housing Dimensions														Spherical roller bearing and accessories
d	d ₂	h	h ₁	g	b	c	a	m	n	v	u	s	D	k	e	Bearing
400	430	350	695	400	360	120	1000	840	220	50	42	M36	600	192	30	23 080
400	430	380	755	430	390	125	1120	950	240	60	48	M42	650	220	30	23 180
400	430	420	835	460	430	135	1220	1030	260	60	48	M42	720	276	35	23 280
400	430	350	695	400	360	120	1000	840	220	50	42	M36	600	220	30	24 080
420	450	360	715	400	360	120	1040	870	220	50	42	M36	620	194	30	23 084
420	450	410	810	460	420	130	1170	1000	260	60	48	M42	700	244	35	23 184
420	460	440	880	470	440	145	1280	1070	260	60	48	M42	760	292	35	23 284
420	450	360	715	400	360	120	1040	870	220	50	42	M36	620	220	30	24 084
440	470	380	755	430	390	125	1120	950	240	60	48	M42	650	200	30	23 088
440	470	420	835	460	430	135	1220	1030	260	60	48	M42	720	246	35	23 188
440	480	460	920	470	440	155	1330	1110	260	70	56	M48	790	300	35	23 288
440	470	380	755	430	390	125	1120	950	240	60	48	M42	650	232	30	24 088
460	500	410	810	460	420	130	1170	1000	260	60	48	M42	680	224	35	23 092
460	500	440	880	470	440	145	1280	1070	260	60	48	M42	760	260	35	23 192
460	500	410	810	460	420	130	1170	1000	260	60	48	M42	680	238	35	24 092
480	510	410	810	460	420	130	1170	1000	260	60	48	M42	700	224	35	23 096
480	520	460	920	470	440	155	1330	1110	260	70	56	M48	790	268	35	23 196
480	510	410	810	460	420	130	1170	1000	260	60	48	M42	700	238	35	24 096
500	530	420	835	460	430	135	1220	1030	260	60	48	M42	720	226	35	230/500
500	530	420	835	460	430	135	1220	1030	260	60	48	M42	720	238	35	240/500
530	560	460	920	470	440	155	1330	1110	260	70	56	M48	780	248	35	230/530
530	560	460	920	470	440	155	1330	1110	260	70	56	M48	780	270	35	240/530

① Locating bearing; ② Non-locating bearing

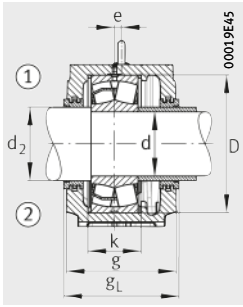

Labyrinth seal NTS

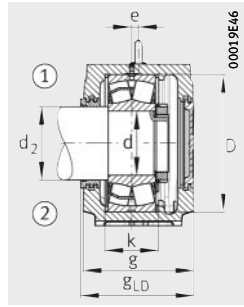

Labyrinth seal NTS
Cover NDK

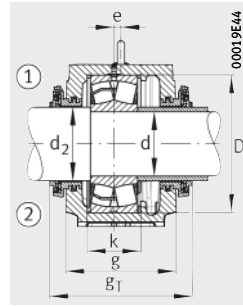

Taconite seal NTC

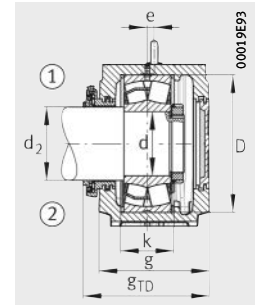

Taconite seal NTC
Cover NDK



									Housing		
Locating ring		Labyrinth seal			Taconite seal			Cover	G	Mass m ≈ kg	Designation
	Quantity		gL mm	gLD mm		gT mm	gTD mm				
NFR600/22	2	NTS92	411	405,5	NTC92	490	445	NDK92	M36	468	SNS3080-Z-D
NFR650/10	2	NTS92	441	435,5	NTC92	520	475	NDK92	M42	660	SNS3180-Z-D
NFR720/10	2	NTS500/430	471	465,5	NTC500/430	550	505	NDK500	M42	895	SNS3280-Z-D
NFR600/10	2	NTS92	411	405,5	NTC92	475	438	NDK92	M36	463	SNS4080-Z-D
NFR620/22	2	NTS96	411	405,5	NTC96	490	445	NDK96	M36	505	SNS3084-Z-D
NFR700/10	2	NTS96	471	465,5	NTC96	550	505	NDK96	M42	799	SNS3184-Z-D
NFR760/10	2	NTS530/460	481	475,5	NTC530/460	560	515	NDK530	M48	956	SNS3284-Z-D
NFR620/10	2	NTS96	411	405,5	NTC96	475	438	NDK96	M36	499	SNS4084-Z-D
NFR650/21,5	2	NTS500	441	435,5	NTC500	520	475	NDK500	M42	649	SNS3088-Z-D
NFR720/10	2	NTS500	471	465,5	NTC500	550	505	NDK500	M42	895	SNS3188-Z-D
NFR790/10	2	NTS560/480	481	475,5	NTC560/480	560	515	NDK560	M48	1 100	SNS3288-Z-D
NFR650/10	2	NTS500	441	435,5	NTC500	505	468	NDK500	M42	642	SNS4088-Z-D
NFR680/30,5	2	NTS530	471	465,5	NTC530	550	505	NDK530	M42	821	SNS3092-Z-D
NFR760/10	2	NTS530	481	475,5	NTC530	560	515	NDK530	M48	966	SNS3192-Z-D
NFR680/10	2	NTS530	471	465,5	NTC530	535	498	NDK530	M42	818	SNS4092-Z-D
NFR700/29,5	2	NTS530/510	471	465,5	NTC530/510	550	505	NDK530	M42	786	SNS3096-Z-D
NFR790/10	2	NTS560/520	481	475,5	NTC560/520	560	515	NDK560	M48	1 100	SNS3196-Z-D
NFR700/10	2	NTS530/510	471	465,5	NTC530/510	535	498	NDK530	M42	780	SNS4096-Z-D
NFR720/29,5	2	NTS560	471	465,5	NTC560	550	505	NDK560	M42	895	SNS30/500-Z-D
NFR720/10	2	NTS560	471	465,5	NTC560	535	498	NDK560	M42	895	SNS40/500-Z-D
NFR780/31,5	2	NTS600	481	475,5	NTC600	560	515	NDK600	M48	1 100	SNS30/530-Z-D
NFR780/10	2	NTS600	481	475,5	NTC600	545	508	NDK600	M48	1 100	SNS40/530-Z-D

Plummer block housings

SNS, split

For spherical roller bearings with tapered bore and adapter sleeve
Inch size shaft

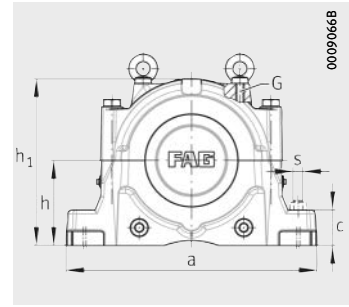
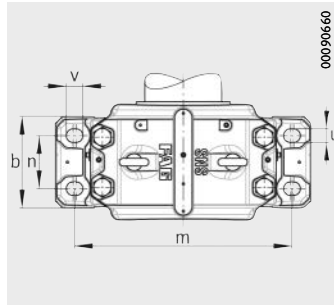

Dimension table - Dimensions in mm

Shaft		Housing Dimensions													Spherical roller bearing and accessories	
		h	h ₁	g	b	c	a	m	n	v	u	s	D	k	e	Bearing
<i>inch</i>	mm															
47/16	112,713	170	333	230	180	70	510	430	100	34	28	M24	280	108	14	22326..-K
41/2	114,300	170	333	230	180	70	510	430	100	34	28	M24	280	108	14	22326..-K
415/16	125,413	180	353	240	190	75	530	450	110	34	28	M24	300	116	15	22328..-K
5	127,000	180	353	240	190	75	530	450	110	34	28	M24	300	116	15	22328..-K
53/16	131,763	190	375	260	210	80	560	480	120	34	28	M24	320	124	10	22330..-K
51/4	133,350	190	375	260	210	80	560	480	120	34	28	M24	320	124	10	22330..-K
57/16	138,113	180	353	240	190	75	530	450	110	34	28	M24	290	115	15	22232..-K
57/16	138,113	210	411	280	230	85	610	510	130	42	35	M30	340	132	10	22332..-K
51/2	139,700	180	353	240	190	75	530	450	110	34	28	M24	290	115	15	22232..-K
51/2	139,700	210	411	280	230	85	610	510	130	42	35	M30	340	132	10	22332..-K
513/16	147,638	190	375	260	210	80	560	480	120	34	28	M24	310	122	10	22234..-K
513/16	147,638	220	434	290	240	90	640	540	140	42	35	M30	360	140	12	22334..-K
513/16	147,638	190	375	260	210	80	560	480	120	34	28	M24	310	122	10	23234..-K
57/8	149,225	190	375	260	210	80	560	480	120	34	28	M24	310	122	10	22234..-K
57/8	149,225	220	434	290	240	90	640	540	140	42	35	M30	360	140	12	22334..-K
57/8	149,225	190	375	260	210	80	560	480	120	34	28	M24	310	122	10	23234..-K
515/16	150,813	190	375	260	210	80	560	480	120	34	28	M24	310	122	10	22234..-K
515/16	150,813	220	434	290	240	90	640	540	140	42	35	M30	360	140	12	22334..-K
515/16	150,813	170	333	230	180	70	510	430	100	34	28	M24	280	108	14	23134..-K
515/16	150,813	170	333	230	180	70	510	430	100	34	28	M24	280	108	14	2315.515¹⁾
515/16	150,813	190	375	260	210	80	560	480	120	34	28	M24	310	122	10	23234..-K
6	152,400	190	375	260	210	80	560	480	120	34	28	M24	310	122	10	22234..-K
6	152,400	220	434	290	240	90	640	540	140	42	35	M30	360	140	12	22334..-K
6	152,400	170	333	230	180	70	510	430	100	34	28	M24	280	108	14	23134..-K
6	152,400	190	375	260	210	80	560	480	120	34	28	M24	310	122	10	23234..-K

① Locating bearing; ② Non-locating bearing

- 1) Split bearing in associated housing has restricted usability. Please ask for further information.
- 2) Alternatively also available with split labyrinth seal NTSG.
- 3) With NTSG: width g_L increased by 16 mm.
- 4) With NTSG: width g_{LD} increased by 8 mm.

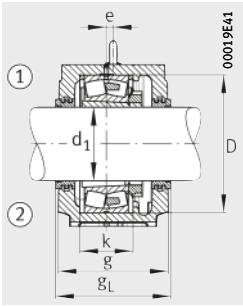

Labyrinth seal NTS

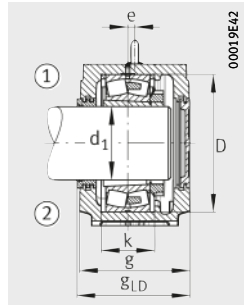

Labyrinth seal NTS
Cover NDK

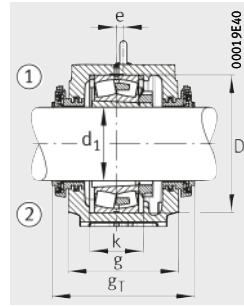

Taconite seal NTC

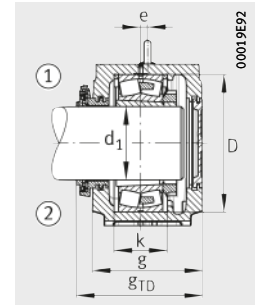

Taconite seal NTC
Cover NDK



									Housing			
Adapter sleeve	Locating ring		Labyrinth seal			Taconite seal			Cover	G	Mass m ≈ kg	Designation
		Quantity		g _L mm	g _{LD} mm		g _T mm	g _{TD} mm				
H2326X407	NFR280/7,5	2	NTS34X407	241	235,5	NTC34X407	299	264	NDK34	M16	75	SNS3134-H-D
H2326X408	NFR280/7,5	2	NTS34X408	241	235,5	NTC34X408	299	264	NDK34	M16	75	SNS3134-H-D
H2328X415	NFR300/7	2	NTS36X415	251	245,5	NTC36X415	310	274,5	NDK36	M16	83	SNS3136-H-D
H2328X500	NFR300/7	2	NTS36X500	251	245,5	NTC36X500	310	274,5	NDK36	M16	83	SNS3136-H-D
H2330X503	NFR320/8	2	NTS38X503	271	265,5	NTC38X503	330	294,5	NDK38	M20	102	SNS3138-H-D
H2330X504	NFR320/8	2	NTS38X504	271	265,5	NTC38X504	330	294,5	NDK38	M20	102	SNS3138-H-D
H3132X507	NFR290/17,5	2	NTS38X507	251	245,5	NTC38X507	312	275,5	NDK38	M16	86	SNS3038-H-D
H2332X507	NFR340/9	2	NTS40X507	291	285,5	NTC40X507	347	313	NDK40	M20	133	SNS3140-H-D
H3132X508	NFR290/17,5	2	NTS38X508	251	245,5	NTC38X508	312	275,5	NDK38	M16	86	SNS3038-H-D
H2332X508	NFR340/9	2	NTS40X508	291	285,5	NTC40X508	347	313	NDK40	M20	133	SNS3140-H-D
H3134(-HG)X513	NFR310/18	2	NTS40X513	271	265,5	NTC40X513	327	293	NDK40	M20	105	SNS3040-H-D
H2334(-HG)X513	NFR360/10	2	NTS48X513	301	295,5	NTC48X513	380	335	NDK48	M20	148	SNS3048-H-D
H2334(-HG)X513	NFR310/6	2	NTS40X513	271	265,5	NTC40X513	326	293	NDK40	M20	105	SNS3234-H-D
H3134(-HG)X514	NFR310/18	2	NTS40X514	271	265,5	NTC40X514	326	293	NDK40	M20	105	SNS3040-H-D
H2334(-HG)X514	NFR360/10	2	NTS48X514	301	295,5	NTC48X514	380	335	NDK48	M20	148	SNS3048-H-D
H2334(-HG)X514	NFR310/6	2	NTS40X514	271	265,5	NTC40X514	326	293	NDK40	M20	105	SNS3234-H-D
H3134(-HG)X515	NFR310/18	2	NTS40X515	271	265,5	NTC40X515	326	293	NDK40	M20	105	SNS3040-H-D
H2334(-HG)X515	NFR360/10	2	NTS48X515	301	295,5	NTC48X515	380	335	NDK48	M20	148	SNS3048-H-D
H3134(-HG)X515	NFR280/10	2	NTS34X515 ²⁾	241 ³⁾	235,5 ⁴⁾	NTC34X515	298	264	NDK34	M16	75	SNS3134-H-D
-	NFR280/10	2	NTS34X515 ²⁾	241 ³⁾	235,5 ⁴⁾	NTC34X515	298	264	NDK34	M16	75	SNS3134-H-D
H2334(-HG)X515	NFR310/6	2	NTS40X515	271	265,5	NTC40X515	326	293	NDK40	M20	105	SNS3234-H-D
H3134(-HG)X600	NFR310/18	2	NTS40X600	271	265,5	NTC40X600	326	293	NDK40	M20	105	SNS3040-H-D
H2334(-HG)X600	NFR360/10	2	NTS48X600	301	295,5	NTC48X600	380	335	NDK48	M20	148	SNS3048-H-D
H3134(-HG)X600	NFR280/10	2	NTS34X600	241	235,5	NTC34X600	298	264	NDK34	M16	75	SNS3134-H-D
H2334(-HG)X600	NFR310/6	2	NTS40X600	271	265,5	NTC40X600	326	293	NDK40	M20	105	SNS3234-H-D

Plummer block housings

SNS, split

For spherical roller bearings with tapered bore and adapter sleeve
Inch size shaft

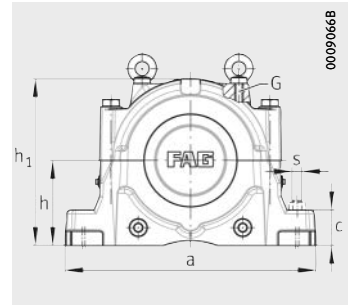
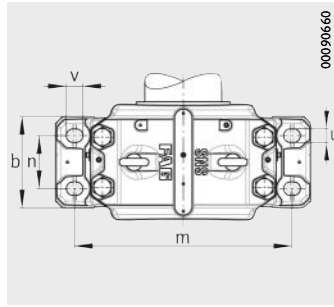

Dimension table (continued) · Dimensions in mm

Shaft		Housing Dimensions													Spherical roller bearing and accessories	
		h	h ₁	g	b	c	a	m	n	v	u	s	D	k	e	Bearing
inch	mm															
6 ⁵ / ₁₆	160,338	190	375	260	210	80	560	480	120	34	28	M24	320	124	10	22236..-K
6 ⁵ / ₁₆	160,338	170	333	230	180	70	510	430	100	34	28	M24	280	108	14	23036..-K
6 ³ / ₈	161,925	190	375	260	210	80	560	480	120	34	28	M24	320	124	10	22236..-K
6 ³ / ₈	161,925	170	333	230	180	70	510	430	100	34	28	M24	280	108	14	23036..-K
6 ⁷ / ₁₆	163,513	190	375	260	210	80	560	480	120	34	28	M24	320	124	10	22236..-K
6 ⁷ / ₁₆	163,513	170	333	230	180	70	510	430	100	34	28	M24	280	108	14	23036..-K
6 ⁷ / ₁₆	163,513	170	333	230	180	70	510	430	100	34	28	M24	280	108	14	230S.607-MA ¹⁾
6 ⁷ / ₁₆	163,513	180	353	240	190	75	530	450	110	34	28	M24	300	116	15	23136..-K
6 ⁷ / ₁₆	163,513	180	353	240	190	75	530	450	110	34	28	M24	300	116	15	231S.607-MA ¹⁾
6 ⁷ / ₁₆	163,513	190	375	260	210	80	560	480	120	34	28	M24	320	124	10	23236..-K
6 ¹ / ₂	165,100	190	375	260	210	80	560	480	120	34	28	M24	320	124	10	22236..-K
6 ¹ / ₂	165,100	170	333	230	180	70	510	430	100	34	28	M24	280	108	14	23036..-K
6 ¹ / ₂	165,100	180	353	240	190	75	530	450	110	34	28	M24	300	116	15	23136..-K
6 ¹ / ₂	165,100	190	375	260	210	80	560	480	120	34	28	M24	320	124	10	23236..-K
6 ³ / ₄	171,450	210	411	280	230	85	610	510	130	42	35	M30	340	132	10	22238..-K
6 ³ / ₄	171,450	240	474	310	260	95	700	600	150	42	35	M30	400	148	12	22338..-K
6 ³ / ₄	171,450	180	353	240	190	75	530	450	110	34	28	M24	290	115	15	23038..-K
6 ³ / ₄	171,450	190	375	260	210	80	560	480	120	34	28	M24	320	124	10	23138..-K
6 ³ / ₄	171,450	210	411	280	230	85	610	510	130	42	35	M30	340	132	10	23238..-K
6 ¹³ / ₁₆	173,038	210	411	280	230	85	610	510	130	42	35	M30	340	132	10	22238..-K
6 ¹³ / ₁₆	173,038	240	474	310	260	95	700	600	150	42	35	M30	400	148	12	22338..-K
6 ¹³ / ₁₆	173,038	180	353	240	190	75	530	450	110	34	28	M24	290	115	15	23038..-K
6 ¹³ / ₁₆	173,038	210	411	280	230	85	610	510	130	42	35	M30	340	132	10	23238..-K
6 ⁷ / ₈	174,625	210	411	280	230	85	610	510	130	42	35	M30	340	132	10	22238..-K
6 ⁷ / ₈	174,625	240	474	310	260	95	700	600	150	42	35	M30	400	148	12	22338..-K
6 ⁷ / ₈	174,625	180	353	240	190	75	530	450	110	34	28	M24	290	115	15	23038..-K
6 ⁷ / ₈	174,625	210	411	280	230	85	610	510	130	42	35	M30	340	132	10	23238..-K

① Locating bearing; ② Non-locating bearing

1) Split bearing in associated housing has restricted usability. Please ask for further information.

2) Alternatively also available with split labyrinth seal NTSG.

3) With NTSG: width g_L increased by 16 mm.

4) With NTSG: width g_{LD} increased by 8 mm.

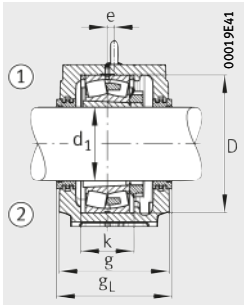

Labyrinth seal NTS

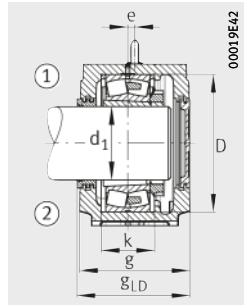

Labyrinth seal NTS
Cover NDK

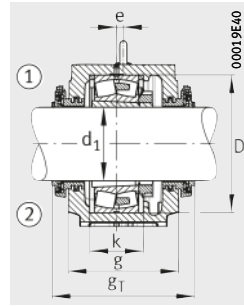

Taconite seal NTC

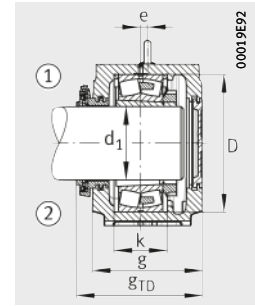

Taconite seal NTC
Cover NDK



										Housing		
Adapter sleeve	Locating ring		Labyrinth seal			Taconite seal			Cover	G	Mass m ≈ kg	Designation
		Quantity		gL mm	gLD mm		gT mm	gTD mm				
H3136(-HG)X605	NFR320/19	2	NTS38X605	271	265,5	NTC38X605	329	294,5	NDK38	M20	102	SNS3138-H-D
H3036(-HG)X605	NFR280/17	2	NTS36X605	241	235,5	NTC36X605	299	264,5	NDK36	M16	74	SNS3036-H-D
H3136(-HG)X606	NFR320/19	2	NTS38X606	271	265,5	NTC38X606	329	294,5	NDK38	M20	102	SNS3138-H-D
H3036(-HG)X606	NFR280/17	2	NTS36X606	241	235,5	NTC36X606	299	264,5	NDK36	M16	74	SNS3036-H-D
H3136(-HG)X607	NFR320/19	2	NTS38X607	271	265,5	NTC38X607	329	294,5	NDK38	M20	102	SNS3138-H-D
H3036(-HG)X607	NFR280/17	2	NTS36X607 ²⁾	241 ³⁾	235,5 ⁴⁾	NTC36X607	299	264,5	NDK36	M16	74	SNS3036-H-D
-	NFR280/17	2	NTS36X607 ²⁾	241 ³⁾	235,5 ⁴⁾	NTC36X607	299	264,5	NDK36	M16	74	SNS3036-H-D
H3136(-HG)X607	NFR300/10	2	NTS36X607 ²⁾	251 ³⁾	245,5 ⁴⁾	NTC36X607	309	274,5	NDK36	M16	83	SNS3136-H-D
-	NFR300/10	2	NTS36X607 ²⁾	251 ³⁾	245,5 ⁴⁾	NTC36X607	309	274,5	NDK36	M16	83	SNS3136-H-D
H2336(-HG)X607	NFR320/6	2	NTS38X607	271	265,5	NTC38X607	329	294,5	NDK38	M20	102	SNS3236-H-D
H3136(-HG)X608	NFR320/19	2	NTS38X608	271	265,5	NTC38X608	329	294,5	NDK38	M20	102	SNS3138-H-D
H3036(-HG)X608	NFR280/17	2	NTS36X608	241	235,5	NTC36X608	299	264,5	NDK36	M16	74	SNS3036-H-D
H3136(-HG)X608	NFR300/10	2	NTS36X608	251	245,5	NTC36X608	309	274,5	NDK36	M16	83	SNS3136-H-D
H2336(-HG)X608	NFR320/6	2	NTS38X608	271	265,5	NTC38X608	329	294,5	NDK38	M20	102	SNS3236-H-D
H3138(-HG)X612	NFR340/10	4	NTS40X612	291	285,5	NTC40X612	346	313	NDK40	M20	133	SNS3140-H-D
H2338(-HG)X612	NFR400/8	2	NTS48X612	321	315,5	NTC48X612	400	355	NDK48	M24	184	SNS3148-H-D
H3038(-HG)X612	NFR290/10	4	NTS38X612	251	245,5	NTC38X612	311	275,5	NDK38	M16	86	SNS3038-H-D
H3138(-HG)X612	NFR320/10	2	NTS38X612	271	265,5	NTC38X612	329	294,5	NDK38	M20	102	SNS3138-H-D
H2338(-HG)X612	NFR340/6	2	NTS40X612	291	285,5	NTC40X612	346	313	NDK40	M20	133	SNS3238-H-D
H3138(-HG)X613	NFR340/10	4	NTS40X613	291	285,5	NTC40X613	346	313	NDK40	M20	133	SNS3140-H-D
H2338(-HG)X613	NFR400/8	2	NTS48X613	321	315,5	NTC48X613	400	355	NDK48	M24	184	SNS3148-H-D
H3038(-HG)X613	NFR290/10	4	NTS38X613	251	245,5	NTC38X613	311	275,5	NDK38	M16	86	SNS3038-H-D
H2338(-HG)X613	NFR340/6	2	NTS40X613	291	285,5	NTC40X613	346	313	NDK40	M20	133	SNS3238-H-D
H3138(-HG)X614	NFR340/10	4	NTS40X614	291	285,5	NTC40X614	346	313	NDK40	M20	133	SNS3140-H-D
H2338(-HG)X614	NFR400/8	2	NTS48X614	321	315,5	NTC48X614	400	355	NDK48	M24	184	SNS3148-H-D
H3038(-HG)X614	NFR290/10	4	NTS38X614	251	245,5	NTC38X614	311	275,5	NDK38	M16	86	SNS3038-H-D
H2338(-HG)X614	NFR340/6	2	NTS40X614	291	285,5	NTC40X614	346	313	NDK40	M20	133	SNS3238-H-D

Plummer block housings

SNS, split
 For spherical roller bearings with tapered bore and adapter sleeve
 Inch size shaft

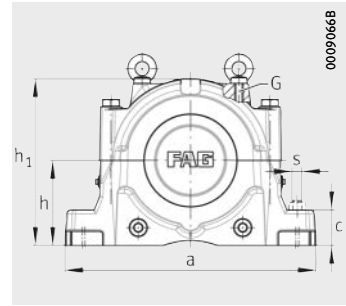
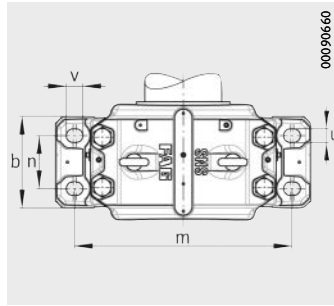

Dimension table (continued) · Dimensions in mm

Shaft		Housing Dimensions														Spherical roller bearing and accessories
		h	h ₁	g	b	c	a	m	n	v	u	s	D	k	e	Bearing
<i>inch</i>	mm															
6¹⁵/₁₆	176,213	210	411	280	230	85	610	510	130	42	35	M30	340	132	10	22238..-K
6¹⁵/₁₆	176,213	240	474	310	260	95	700	600	150	42	35	M30	400	148	12	22338..-K
6¹⁵/₁₆	176,213	180	353	240	190	75	530	450	110	34	28	M24	290	115	15	23038..-K
6¹⁵/₁₆	176,213	190	375	260	210	80	560	480	120	34	28	M24	320	124	10	23138..-K
6¹⁵/₁₆	176,213	190	375	260	210	80	560	480	120	34	28	M24	320	124	10	2315.615
6¹⁵/₁₆	176,213	210	411	280	230	85	610	510	130	42	35	M30	340	132	10	23238..-K
7	177,800	210	411	280	230	85	610	510	130	42	35	M30	340	132	10	22238..-K
7	177,800	220	434	290	240	90	640	540	140	42	35	M30	360	140	12	22240..-K
7	177,800	240	474	310	260	95	700	600	150	42	35	M30	400	148	12	22338..-K
7	177,800	260	516	320	280	100	770	650	160	50	42	M36	420	166	13	22340..-K
7	177,800	180	353	240	190	75	530	450	110	34	28	M24	290	115	15	23038..-K
7	177,800	180	353	240	190	75	530	450	110	34	28	M24	290	115	15	2305.700¹⁾
7	177,800	190	375	260	210	80	560	480	120	34	28	M24	310	122	10	23040..-K
7	177,800	210	411	280	230	85	610	510	130	42	35	M30	340	132	10	23140..-K
7	177,800	210	411	280	230	85	610	510	130	42	35	M30	340	132	10	2315.700
7	177,800	210	411	280	230	85	610	510	130	42	35	M30	340	132	10	23238..-K
7	177,800	220	434	290	240	90	640	540	140	42	35	M30	360	140	12	23240..-K
7¹/₈	180,975	220	434	290	240	90	640	540	140	42	35	M30	360	140	12	22240..-K
7¹/₈	180,975	260	516	320	280	100	770	650	160	50	42	M36	420	166	13	22340..-K
7¹/₈	180,975	190	375	260	210	80	560	480	120	34	28	M24	310	122	10	23040..-K
7¹/₈	180,975	220	434	290	240	90	640	540	140	42	35	M30	360	140	12	23240..-K
7³/₁₆	182,563	220	434	290	240	90	640	540	140	42	35	M30	360	140	12	22240..-K
7³/₁₆	182,563	260	516	320	280	100	770	650	160	50	42	M36	420	166	13	22340..-K
7³/₁₆	182,563	190	375	260	210	80	560	480	120	34	28	M24	310	122	10	23040..-K
7³/₁₆	182,563	210	411	280	230	85	610	510	130	42	35	M30	340	132	10	23140..-K
7³/₁₆	182,563	220	434	290	240	90	640	540	140	42	35	M30	360	140	12	23240..-K

① Locating bearing; ② Non-locating bearing

¹⁾ Split bearing in associated housing has restricted usability. Please ask for further information.

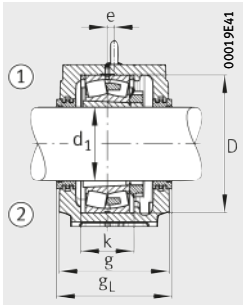

Labyrinth seal NTS

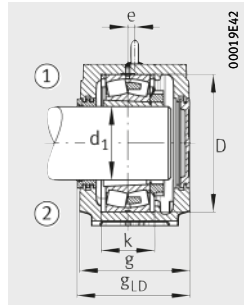

Labyrinth seal NTS
Cover NDK

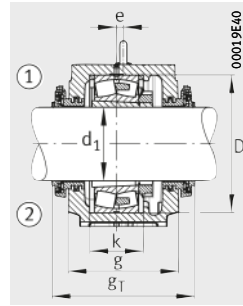

Taconite seal NTC

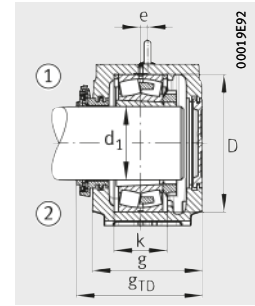

Taconite seal NTC
Cover NDK



										Housing		
Adapter sleeve	Locating ring		Labyrinth seal			Taconite seal			Cover	G	Mass m ≈ kg	Designation
		Quantity		g _L mm	g _{LD} mm		g _T mm	g _{TD} mm				
H3138(-HG)X615	NFR340/10	4	NTS40X615	291	285,5	NTC40X615	346	313	NDK40	M20	133	SNS3140-H-D
H2338(-HG)X615	NFR400/8	2	NTS48X615	321	315,5	NTC48X615	400	355	NDK48	M24	184	SNS3148-H-D
H3038(-HG)X615	NFR290/10	4	NTS38X615	251	245,5	NTC38X615	309	274,5	NDK38	M16	86	SNS3038-H-D
H3138(-HG)X615	NFR320/10	2	NTS38X615	271	265,5	NTC38X615	329	294,5	NDK38	M20	102	SNS3138-H-D
-	NFR320/10	2	NTS38X615	271	265,5	NTC38X615	329	294,5	NDK38	M20	102	SNS3138-H-D
H2338(-HG)X615	NFR340/6	2	NTS40X615	291	285,5	NTC40X615	346	313	NDK40	M20	133	SNS3238-H-D
H3138(-HG)X700	NFR340/10	4	NTS40X700	291	285,5	NTC40X700	346	313	NDK40	M20	133	SNS3140-H-D
H3140(-HG)X700	NFR360/21	2	NTS48X700	301	295,5	NTC48X700	380	335	NDK48	M20	148	SNS3048-H-D
H2338(-HG)X700	NFR400/8	2	NTS48X700	321	315,5	NTC48X700	400	355	NDK48	M24	184	SNS3148-H-D
H2340(-HG)X700	NFR420/14	2	NTS56X700	331	325,5	NTC56X700	410	365	NDK56	M24	249	SNS3056-H-D
H3038(-HG)X700	NFR290/10	4	NTS38X700	251	245,5	NTC38X700	311	275,5	NDK38	M16	86	SNS3038-H-D
-	NFR290/10	4	NTS38X700	251	245,5	NTC38X700	311	275,5	NDK38	M16	86	SNS3038-H-D
H3040(-HG)X700	NFR310/10	4	NTS40X700	271	265,5	NTC40X700	326	293	NDK40	M20	105	SNS3040-H-D
H3140(-HG)X700	NFR340/10	2	NTS40X700	291	285,5	NTC40X700	346	313	NDK40	M20	133	SNS3140-H-D
-	NFR340/10	2	NTS40X700	291	285,5	NTC40X700	346	313	NDK40	M20	133	SNS3140-H-D
H2338(-HG)X700	NFR340/6	2	NTS40X700	291	285,5	NTC40X700	346	313	NDK40	M20	133	SNS3238-H-D
H2340(-HG)X700	NFR360/6	2	NTS48X700	301	295,5	NTC48X700	380	335	NDK48	M20	148	SNS3240-H-D
H3140(-HG)X702	NFR360/21	2	NTS48X702	301	295,5	NTC48X702	380	335	NDK48	M20	148	SNS3048-H-D
H2340(-HG)X702	NFR420/14	2	NTS56X702	331	325,5	NTC56X702	410	365	NDK56	M24	249	SNS3056-H-D
H3040(-HG)X702	NFR310/10	4	NTS40X702	271	265,5	NTC40X702	326	293	NDK40	M20	105	SNS3040-H-D
H2340(-HG)X702	NFR360/6	2	NTS48X702	301	295,5	NTC48X702	380	335	NDK48	M20	148	SNS3240-H-D
H3140(-HG)X703	NFR360/21	2	NTS48X703	301	295,5	NTC48X703	380	335	NDK48	M20	148	SNS3048-H-D
H2340(-HG)X703	NFR420/14	2	NTS56X703	331	325,5	NTC56X703	410	365	NDK56	M24	249	SNS3056-H-D
H3040(-HG)X703	NFR310/10	4	NTS40X703	271	265,5	NTC40X703	326	293	NDK40	M20	105	SNS3040-H-D
H3140(-HG)X703	NFR340/10	2	NTS40X703	291	285,5	NTC40X703	346	313	NDK40	M20	133	SNS3140-H-D
H2340(-HG)X703	NFR360/6	2	NTS48X703	301	295,5	NTC48X703	380	335	NDK48	M20	148	SNS3240-H-D

Plummer block housings

SNS, split
 For spherical roller bearings with tapered bore and adapter sleeve
 Inch size shaft

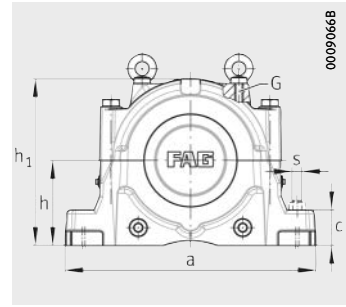
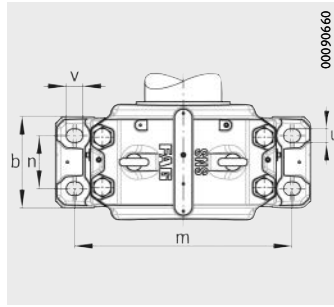

Dimension table (continued) · Dimensions in mm

Shaft		Housing Dimensions														Spherical roller bearing and accessories
		h	h ₁	g	b	c	a	m	n	v	u	s	D	k	e	Bearing
<i>inch</i>	mm															
7¹/₄	184,150	220	434	290	240	90	640	540	140	42	35	M30	360	140	12	22240..-K
7¹/₄	184,150	260	516	320	280	100	770	650	160	50	42	M36	420	166	13	22340..-K
7¹/₄	184,150	190	375	260	210	80	560	480	120	34	28	M24	310	122	10	23040..-K
7¹/₄	184,150	220	434	290	240	90	640	540	140	42	35	M30	360	140	12	23240..-K
7¹³/₁₆	198,438	240	474	310	260	95	700	600	150	42	35	M30	400	148	12	22244..-K
7¹³/₁₆	198,438	210	411	280	230	85	610	510	130	42	35	M30	340	130	10	23044..-K
7⁷/₈	200,025	240	474	310	260	95	700	600	150	42	35	M30	400	148	12	22244..-K
7⁷/₈	200,025	210	411	280	230	85	610	510	130	42	35	M30	340	130	10	23044..-K
7¹⁵/₁₆	201,613	240	474	310	260	95	700	600	150	42	35	M30	400	148	12	22244..-K
7¹⁵/₁₆	201,613	280	550	320	280	105	790	670	160	50	42	M36	460	166	16	22344..-K
7¹⁵/₁₆	201,613	210	411	280	230	85	610	510	130	42	35	M30	340	130	10	23044..-K
7¹⁵/₁₆	201,613	220	434	290	240	90	640	540	140	42	35	M30	370	140	12	23144..-K
7¹⁵/₁₆	201,613	240	474	310	260	95	700	600	150	42	35	M30	400	164	12	23244..-K
8	203,200	240	474	310	260	95	700	600	150	42	35	M30	400	148	12	22244..-K
8	203,200	210	411	280	230	85	610	510	130	42	35	M30	340	130	10	23044..-K
8⁷/₁₆	214,313	260	516	320	280	100	770	650	160	50	42	M36	440	164	13	22248..-K
8⁷/₁₆	214,313	220	434	290	240	90	640	540	140	42	35	M30	360	140	12	23048..-K
8⁷/₁₆	214,313	220	434	290	240	90	640	540	140	42	35	M30	360	140	12	2305.807¹⁾
8¹/₂	215,900	260	516	320	280	100	770	650	160	50	42	M36	440	164	13	22248..-K
8¹/₂	215,900	220	434	290	240	90	640	540	140	42	35	M30	360	140	12	23048..-K
8¹/₂	215,900	220	434	290	240	90	640	540	140	42	35	M30	360	140	12	2305.808¹⁾
8¹⁵/₁₆	227,013	260	516	320	280	100	770	650	160	50	42	M36	440	164	13	22248..-K
8¹⁵/₁₆	227,013	300	591	350	310	110	830	710	190	50	42	M36	500	180	22	22348..-K
8¹⁵/₁₆	227,013	220	434	290	240	90	640	540	140	42	35	M30	360	140	12	23048..-K
8¹⁵/₁₆	227,013	240	474	310	260	95	700	600	150	42	35	M30	400	148	12	23148..-K
8¹⁵/₁₆	227,013	260	516	320	280	100	770	650	160	50	42	M36	440	180	13	23248..-K

① Locating bearing; ② Non-locating bearing

¹⁾ Split bearing in associated housing has restricted usability. Please ask for further information.

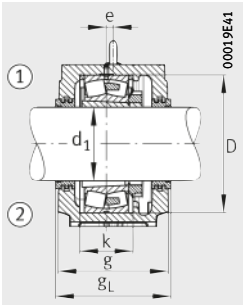

Labyrinth seal NTS

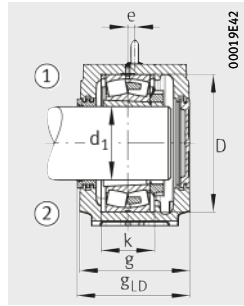

Labyrinth seal NTS
Cover NDK

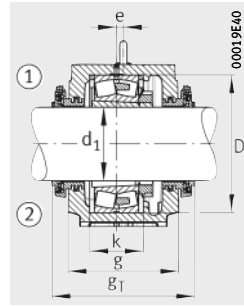

Taconite seal NTC

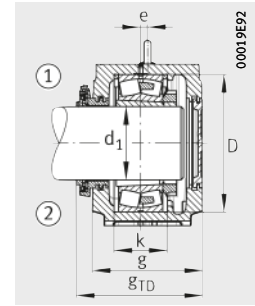

Taconite seal NTC
Cover NDK



									Housing			
Adapter sleeve	Locating ring		Labyrinth seal			Taconite seal			Cover	G	Mass m ≈ kg	Designation
		Quantity		g _L mm	g _{LD} mm		g _T mm	g _{TD} mm				
H3140(-HG)X704	NFR360/21	2	NTS48X704	301	295,5	NTC48X704	380	335	NDK48	M20	148	SNS3048-H-D
H2340(-HG)X704	NFR420/14	2	NTS56X704	331	325,5	NTC56X704	410	365	NDK56	M24	249	SNS3056-H-D
H3040(-HG)X704	NFR310/10	4	NTS40X704	271	265,5	NTC40X704	326	293	NDK40	M20	105	SNS3040-H-D
H2340(-HG)X704	NFR360/6	2	NTS48X704	301	295,5	NTC48X704	380	335	NDK48	M20	148	SNS3240-H-D
H3144X(-HG)X713	NFR400/10	4	NTS48X713	321	315,5	NTC48X713	400	355	NDK48	M24	184	SNS3148-H-D
H3044(-HG)X713	NFR340/10	4	NTS44X713	291	285,5	NTC44X713	370	325	NDK44	M20	129	SNS3044-H-D
H3144X(-HG)X714	NFR400/10	4	NTS48X714	321	315,5	NTC48X714	400	355	NDK48	M24	184	SNS3148-H-D
H3044(-HG)X714	NFR340/10	4	NTS44X714	291	285,5	NTC44X714	370	325	NDK44	M20	129	SNS3044-H-D
H3144X(-HG)X715	NFR400/10	4	NTS48X715	321	315,5	NTC48X715	400	355	NDK48	M24	184	SNS3148-H-D
H2344(-HG)X715	NFR460/10,5	2	NTS56X715	331	325,5	NTC56X715	410	365	NDK56	M24	264	SNS3156-H-D
H3044(-HG)X715	NFR340/10	4	NTS44X715	291	285,5	NTC44X715	370	325	NDK44	M20	129	SNS3044-H-D
H3144X(-HG)X715	NFR370/10	2	NTS44X715	301	295,5	NTC44X715	380	335	NDK44	M20	146	SNS3144-H-D
H2344(-HG)X715	NFR400/10	2	NTS48X715	321	315,5	NTC48X715	400	355	NDK48	M24	183	SNS3244-H-D
H3144X(-HG)X800	NFR400/10	4	NTS48X800	321	315,5	NTC48X800	400	355	NDK48	M24	184	SNS3148-H-D
H3044(-HG)X800	NFR340/10	4	NTS44X800	291	285,5	NTC44X800	370	325	NDK44	M20	129	SNS3044-H-D
H3148X(-HG)X807	NFR440/22	2	NTS52X807	331	325,5	NTC52X807	410	365	NDK52	M24	238	SNS3152-H-D
H3048(-HG)X807	NFR360/12	4	NTS48X807	301	295,5	NTC48X807	380	335	NDK48	M20	148	SNS3048-H-D
-	NFR360/12	4	NTS48X807	301	295,5	NTC48X807	380	335	NDK48	M20	148	SNS3048-H-D
H3148X(-HG)X808	NFR440/22	2	NTS52X808	331	325,5	NTC52X808	410	365	NDK52	M24	238	SNS3152-H-D
H3048(-HG)X808	NFR360/12	4	NTS48X808	301	295,5	NTC48X808	380	335	NDK48	M20	148	SNS3048-H-D
-	NFR360/12	4	NTS48X808	301	295,5	NTC48X808	380	335	NDK48	M20	148	SNS3048-H-D
H3148X(-HG)X815	NFR440/22	2	NTS52X815	331	325,5	NTC52X815	410	365	NDK52	M24	238	SNS3152-H-D
H2348(-HG)X815	NFR500/12,5	2	NTS60X815	361	355,5	NTC60X815	440	395	NDK60	M30	317	SNS3160-H-D
H3048(-HG)X815	NFR360/12	4	NTS48X815	301	295,5	NTC48X815	380	335	NDK48	M20	148	SNS3048-H-D
H3148X(-HG)X815	NFR400/10	2	NTS48X815	321	315,5	NTC48X815	400	355	NDK48	M24	184	SNS3148-H-D
H2348(-HG)X815	NFR440/10	2	NTS52X815	331	325,5	NTC52X815	410	365	NDK52	M24	235	SNS3248-H-D

Plummer block housings

SNS, split
For spherical roller bearings with tapered bore and adapter sleeve
Inch size shaft

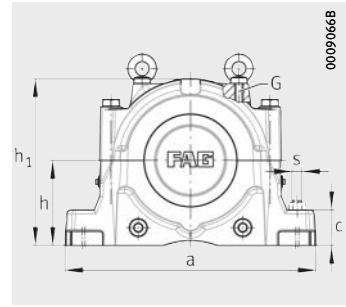
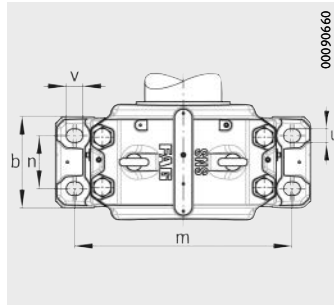

Dimension table (continued) · Dimensions in mm

Shaft		Housing Dimensions														Spherical roller bearing and accessories
		h	h ₁	g	b	c	a	m	n	v	u	s	D	k	e	Bearing
inch	mm															
97/16	239,713	240	474	310	260	95	700	600	150	42	35	M30	400	148	12	23052..-K
97/16	239,713	260	516	320	280	100	770	650	160	50	42	M36	440	164	13	23152..-K
97/16	239,713	260	516	320	280	100	770	650	160	50	42	M36	440	164	13	2315.907¹⁾
97/16	239,713	300	591	350	310	110	830	710	190	50	42	M36	480	194	22	23252..-K
91/2	241,300	300	591	350	310	110	830	710	190	50	42	M36	480	181	22	22252..-K
91/2	241,300	320	631	370	330	115	880	750	200	50	42	M36	540	196	23	22352..-K
91/2	241,300	240	474	310	260	95	700	600	150	42	35	M30	400	148	12	23052..-K
91/2	241,300	240	474	310	260	95	700	600	150	42	35	M30	400	148	12	2305.908
91/2	241,300	260	516	320	280	100	770	650	160	50	42	M36	440	164	13	23152..-K
91/2	241,300	260	516	320	280	100	770	650	160	50	42	M36	440	164	13	2315.908¹⁾
91/2	241,300	300	591	350	310	110	830	710	190	50	42	M36	480	194	22	23252..-K
915/16	252,413	260	516	320	280	100	770	650	160	50	42	M36	420	166	13	23056..-K
10	254,000	300	591	350	310	110	830	710	190	50	42	M36	500	180	22	22256..-K
10	254,000	260	516	320	280	100	770	650	160	50	42	M36	420	166	13	23056..-K
10	254,000	260	516	320	280	100	770	650	160	50	42	M36	420	166	13	2305.1000¹⁾
10	254,000	280	550	320	280	105	790	670	160	50	42	M36	460	166	16	23156..-K
10	254,000	280	550	320	280	105	790	670	160	50	42	M36	460	166	16	2315.1000
107/16	265,113	300	591	350	310	110	830	710	190	50	42	M36	500	180	22	22256..-K
107/16	265,113	340	675	400	360	120	950	810	220	50	42	M36	580	210	24	22356..-K
107/16	265,113	260	516	320	280	100	770	650	160	50	42	M36	420	166	13	23056..-K
107/16	265,113	280	550	320	280	105	790	670	160	50	42	M36	460	166	16	23156..-K
107/16	265,113	300	591	350	310	110	830	710	190	50	42	M36	500	196	22	23256..-K
101/2	266,700	300	591	350	310	110	830	710	190	50	42	M36	500	180	22	22256..-K
101/2	266,700	340	675	400	360	120	950	810	220	50	42	M36	580	210	24	22356..-K
101/2	266,700	260	516	320	280	100	770	650	160	50	42	M36	420	166	13	23056..-K
101/2	266,700	280	550	320	280	105	790	670	160	50	42	M36	460	166	16	23156..-K
101/2	266,700	300	591	350	310	110	830	710	190	50	42	M36	500	196	22	23256..-K

① Locating bearing; ② Non-locating bearing

¹⁾ Split bearing in associated housing has restricted usability. Please ask for further information.

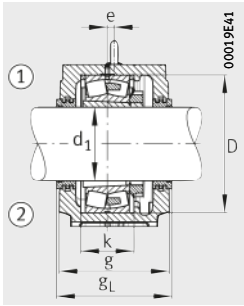

Labyrinth seal NTS

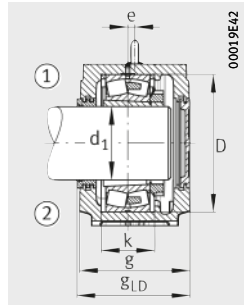

Labyrinth seal NTS
Cover NDK

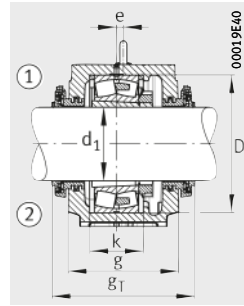

Taconite seal NTC

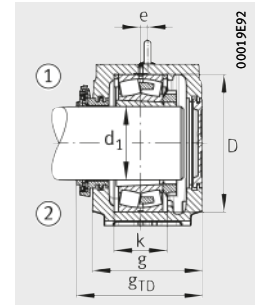

Taconite seal NTC
Cover NDK



										Housing		
Adapter sleeve	Locating ring		Labyrinth seal			Taconite seal			Cover	G	Mass m ≈ kg	Designation
		Quantity		gL mm	gL _D mm		g _T mm	g _{TD} mm				
H3052(-HG)X907	NFR400/22	2	NTS52X907	321	315,5	NTC52X907	400	355	NDK52	M24	180	SNS3052-H-D
H3152X(-HG)X907	NFR440/10	2	NTS52X907	331	325,5	NTC52X907	410	365	NDK52	M24	238	SNS3152-H-D
-	NFR440/10	2	NTS52X907	331	325,5	NTC52X907	410	365	NDK52	M24	238	SNS3152-H-D
H2352(-HG)X907	NFR480/10	2	NTS64X907	361	355,5	NTC64X907	440	395	NDK64	M30	331	SNS3252-H-D
H3152X(-HG)X908	NFR480/25,5	2	NTS64X908	361	355,5	NTC64X908	440	395	NDK64	M30	332	SNS3064-H-D
H2352(-HG)X908	NFR540/15,5	2	NTS64X908	381	375,5	NTC64X908	460	415	NDK64	M30	368	SNS3164-H-D
H3052(-HG)X908	NFR400/22	2	NTS52X908	321	315,5	NTC52X908	400	355	NDK52	M24	180	SNS3052-H-D
-	NFR400/22	2	NTS52X908	321	315,5	NTC52X908	400	355	NDK52	M24	180	SNS3052-H-D
H3152X(-HG)X908	NFR440/10	2	NTS52X908	331	325,5	NTC52X908	410	365	NDK52	M24	238	SNS3152-H-D
-	NFR440/10	2	NTS52X908	331	325,5	NTC52X908	410	365	NDK52	M24	238	SNS3152-H-D
H2352(-HG)X908	NFR480/10	2	NTS64X908	361	355,5	NTC64X908	440	395	NDK64	M30	331	SNS3252-H-D
H3056(-HG)X915	NFR420/10	6	NTS56X915	331	325,5	NTC56X915	410	365	NDK56	M24	249	SNS3056-H-D
H3156X(-HG)X1000	NFR500/25	2	NTS60X1000	361	355,5	NTC60X1000	440	395	NDK60	M30	317	SNS3160-H-D
H3056(-HG)X1000	NFR420/10	6	NTS56X1000	331	325,5	NTC56X1000	410	365	NDK56	M24	249	SNS3056-H-D
-	NFR420/10	6	NTS56X1000	331	325,5	NTC56X1000	410	365	NDK56	M24	249	SNS3056-H-D
H3156X(-HG)X1000	NFR460/10	2	NTS56X1000	331	325,5	NTC56X1000	410	365	NDK56	M24	264	SNS3156-H-D
-	NFR460/10	2	NTS56X1000	331	325,5	NTC56X1000	410	365	NDK56	M24	264	SNS3156-H-D
H3156X(-HG)X1007	NFR500/25	2	NTS60X1007	361	355,5	NTC60X1007	440	395	NDK60	M30	317	SNS3160-H-D
H2356(-HG)X1007	NFR580/17,5	2	NTS68X1007	411	405,5	NTC68X1007	490	445	NDK68	M30	461	SNS3168-H-D
H3056(-HG)X1007	NFR420/10	6	NTS56X1007	331	325,5	NTC56X1007	410	365	NDK56	M24	249	SNS3056-H-D
H3156X(-HG)X1007	NFR460/10	2	NTS56X1007	331	325,5	NTC56X1007	410	365	NDK56	M24	264	SNS3156-H-D
H2356(-HG)X1007	NFR500/10	2	NTS60X1007	361	355,5	NTC60X1007	440	395	NDK60	M30	314	SNS3256-H-D
H3156X(-HG)X1008	NFR500/25	2	NTS60X1008	361	355,5	NTC60X1008	440	395	NDK60	M30	317	SNS3160-H-D
H2356(-HG)X1008	NFR580/17,5	2	NTS68X1008	411	405,5	NTC68X1008	490	445	NDK68	M30	461	SNS3168-H-D
H3056(-HG)X1008	NFR420/10	6	NTS56X1008	331	325,5	NTC56X1008	410	365	NDK56	M24	249	SNS3056-H-D
H3156X(-HG)X1008	NFR460/10	2	NTS56X1008	331	325,5	NTC56X1008	410	365	NDK56	M24	264	SNS3156-H-D
H2356(-HG)X1008	NFR500/10	2	NTS60X1008	361	355,5	NTC60X1008	440	395	NDK60	M30	314	SNS3256-H-D

Plummer block housings

SNS, split
 For spherical roller bearings with tapered bore and adapter sleeve
 Inch size shaft

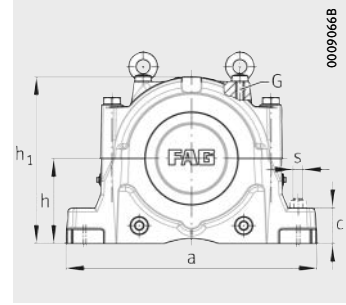
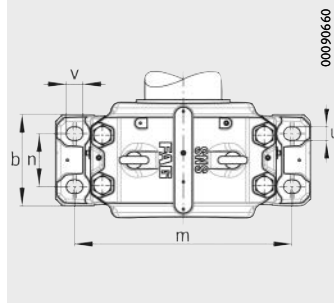

Dimension table (continued) · Dimensions in mm

Shaft		Housing Dimensions														Spherical roller bearing and accessories
		h	h ₁	g	b	c	a	m	n	v	u	s	D	k	e	Bearing
inch	mm															
10¹⁵/₁₆	277,813	320	631	370	330	115	880	750	200	50	42	M36	540	196	23	22260..-K
10¹⁵/₁₆	277,813	280	550	320	280	105	790	670	160	50	42	M36	460	168	16	23060..-K
10¹⁵/₁₆	277,813	280	550	320	280	105	790	670	160	50	42	M36	460	168	16	230S.1015¹⁾
10¹⁵/₁₆	277,813	300	591	350	310	110	830	710	190	50	42	M36	500	180	22	23160..-K
10¹⁵/₁₆	277,813	320	631	370	330	115	880	750	200	50	42	M36	540	212	23	23260..-K
11	279,400	320	631	370	330	115	880	750	200	50	42	M36	540	196	23	22260..-K
11	279,400	280	550	320	280	105	790	670	160	50	42	M36	460	168	16	23060..-K
11	279,400	280	550	320	280	105	790	670	160	50	42	M36	460	168	16	230S.1100¹⁾
11	279,400	300	591	350	310	110	830	710	190	50	42	M36	500	180	22	23160..-K
11	279,400	300	591	350	310	110	830	710	190	50	42	M36	500	180	22	231S.1100¹⁾
11	279,400	320	631	370	330	115	880	750	200	50	42	M36	540	212	23	23260..-K
11⁷/₁₆	290,513	300	591	350	310	110	830	710	190	50	42	M36	480	181	22	23064..-K
11¹/₂	292,100	340	675	400	360	120	950	810	220	50	42	M36	580	190	24	22264..-K
11¹/₂	292,100	300	591	350	310	110	830	710	190	50	42	M36	480	181	22	23064..-K
11¹⁵/₁₆	303,213	300	591	350	310	110	830	710	190	50	42	M36	480	181	22	23064..-K
11¹⁵/₁₆	303,213	320	631	370	330	115	880	750	200	50	42	M36	540	196	23	23164..-K
11¹⁵/₁₆	303,213	340	675	400	360	120	950	810	220	50	42	M36	580	228	24	23264..-K
12	304,800	340	675	400	360	120	950	810	220	50	42	M36	580	190	24	22264..-K
12	304,800	300	591	350	310	110	830	710	190	50	42	M36	480	181	22	23064..-K
12	304,800	300	591	350	310	110	830	710	190	50	42	M36	480	181	22	230S.1200¹⁾
12	304,800	320	631	370	330	115	880	750	200	50	42	M36	540	196	23	23164..-K
12	304,800	320	631	370	330	115	880	750	200	50	42	M36	540	196	23	231S.1200¹⁾
12	304,800	340	675	400	360	120	950	810	220	50	42	M36	580	228	24	23264..-K
12	304,800	340	675	400	360	120	950	810	220	50	42	M36	580	228	24	232S.1200¹⁾
12⁷/₁₆	315,913	320	631	370	330	115	880	750	200	50	42	M36	520	197	23	23068..-K
12⁷/₁₆	315,913	340	675	400	360	120	950	810	220	50	42	M36	580	210	24	23168..-K
12⁷/₁₆	315,913	360	715	400	360	120	1040	870	220	50	42	M36	620	244	30	23268..-K

① Locating bearing; ② Non-locating bearing

¹⁾ Split bearing in associated housing has restricted usability. Please ask for further information.

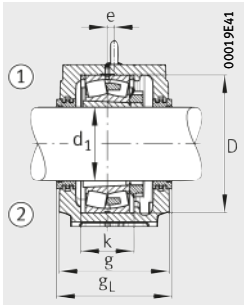

Labyrinth seal NTS

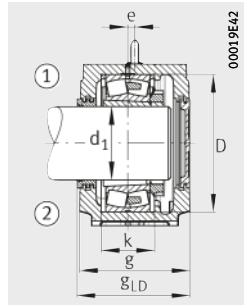

Labyrinth seal NTS
Cover NDK

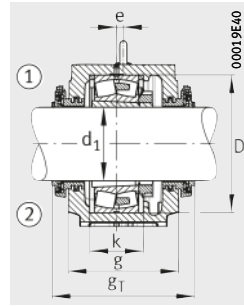

Taconite seal NTC

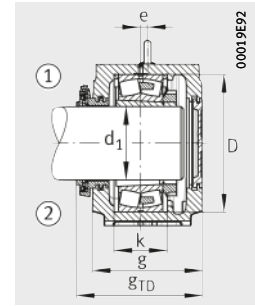

Taconite seal NTC
Cover NDK



										Housing		
Adapter sleeve	Locating ring	Quantity	Labyrinth seal			Taconite seal			Cover	G	Mass m ≈ kg	Designation
				g _L mm	g _{LD} mm		g _T mm	g _{TD} mm				
H3160(-HG)X1015	NFR540/28	2	NTS64X1015	381	375,5	NTC64X1015	460	415	NDK64	M30	368	SNS3164-H-D
H3060(-HG)X1015	NFR460/25	2	NTS60X1015	331	325,5	NTC60X1015	410	365	NDK60	M24	260	SNS3060-H-D
-	NFR460/25	2	NTS60X1015	331	325,5	NTC60X1015	410	365	NDK60	M24	260	SNS3060-H-D
H3160(-HG)X1015	NFR500/10	2	NTS60X1015	361	355,5	NTC60X1015	440	395	NDK60	M30	317	SNS3160-H-D
H3260(-HG)X1015	NFR540/10	2	NTS64X1015	381	375,5	NTC64X1015	460	415	NDK64	M30	364	SNS3260-H-D
H3160(-HG)X1100	NFR540/28	2	NTS64X1100	381	375,5	NTC64X1100	460	415	NDK64	M30	368	SNS3164-H-D
H3060(-HG)X1100	NFR460/25	2	NTS60X1100	331	325,5	NTC60X1100	410	365	NDK60	M24	260	SNS3060-H-D
-	NFR460/25	2	NTS60X1100	331	325,5	NTC60X1100	410	365	NDK60	M24	260	SNS3060-H-D
H3160(-HG)X1100	NFR500/10	2	NTS60X1100	361	355,5	NTC60X1100	440	395	NDK60	M30	317	SNS3160-H-D
-	NFR500/10	2	NTS60X1100	361	355,5	NTC60X1100	440	395	NDK60	M30	317	SNS3160-H-D
H3260(-HG)X1100	NFR540/10	2	NTS64X1100	381	375,5	NTC64X1100	460	415	NDK64	M30	364	SNS3260-H-D
H3064(-HG)X1107	NFR480/10	6	NTS64X1107	361	355,5	NTC64X1107	440	395	NDK64	M30	332	SNS3064-H-D
H3164(-HG)X1108	NFR580/20	2	NTS68X1108	411	405,5	NTC68X1108	490	445	NDK68	M30	466	SNS2264-H-D
H3064(-HG)X1108	NFR480/10	6	NTS64X1108	361	355,5	NTC64X1108	440	395	NDK64	M30	332	SNS3064-H-D
H3064-HGX1115	NFR480/10	6	NTS64X1115	361	355,5	NTC64X1115	440	395	NDK64	M30	332	SNS3064-H-D
H3164-HGX1115	NFR540/10	2	NTS64X1115	381	375,5	NTC64X1115	460	415	NDK64	M30	368	SNS3164-H-D
H3264-HGX1115	NFR580/10	2	NTS68X1115	411	405,5	NTC68X1115	490	445	NDK68	M30	457	SNS3264-H-D
H3164-HGX1200	NFR580/20	2	NTS68X1200	411	405,5	NTC68X1200	490	445	NDK68	M30	466	SNS2264-H-D
H3064-HGX1200	NFR480/10	6	NTS64X1200	361	355,5	NTC64X1200	440	395	NDK64	M30	332	SNS3064-H-D
-	NFR480/10	6	NTS64X1200	361	355,5	NTC64X1200	440	395	NDK64	M30	332	SNS3064-H-D
H3164-HGX1200	NFR540/10	2	NTS64X1200	381	375,5	NTC64X1200	460	415	NDK64	M30	368	SNS3164-H-D
-	NFR540/10	2	NTS64X1200	381	375,5	NTC64X1200	460	415	NDK64	M30	368	SNS3164-H-D
H3264-HGX1200	NFR580/10	2	NTS68X1200	411	405,5	NTC68X1200	490	445	NDK68	M30	457	SNS3264-H-D
-	NFR580/10	2	NTS68X1200	411	405,5	NTC68X1200	490	445	NDK68	M30	457	SNS3264-H-D
H3068-HGX1207	NFR520/16	4	NTS68X1207	381	375,5	NTC68X1207	460	415	NDK68	M30	386	SNS3068-H-D
H3168-HGX1207	NFR580/10	2	NTS68X1207	411	405,5	NTC68X1207	490	445	NDK68	M30	461	SNS3168-H-D
H3268-HGX1207	NFR620/10	2	NTS76X1207	411	405,5	NTC76X1207	490	445	NDK76	M36	530	SNS3268-H-D

Plummer block housings

SNS, split
For spherical roller bearings with tapered bore and adapter sleeve
Inch size shaft

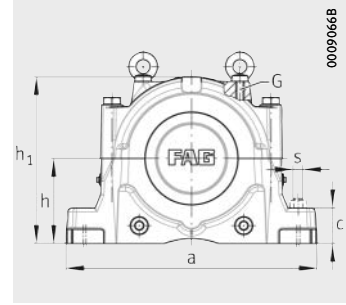
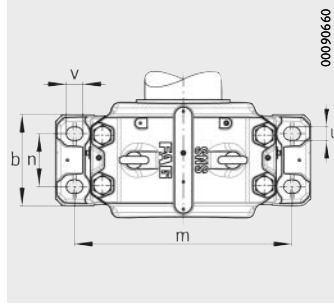

Dimension table (continued) · Dimensions in mm

Shaft		Housing Dimensions															Spherical roller bearing and accessories	
		h	h ₁	g	b	c	a	m	n	v	u	s	D	k	e	Bearing	Adapter sleeve	
inch	mm																	
12 ^{1/2}	317,500	320	631	370	330	115	880	750	200	50	42	M36	520	197	23	23068..-K	H3068-HGX1208	
12 ^{1/2}	317,500	340	675	400	360	120	950	810	220	50	42	M36	580	210	24	23168..-K	H3168-HGX1208	
12 ^{1/2}	317,500	340	675	400	360	120	950	810	220	50	42	M36	580	210	24	2315.1208	–	
12 ^{1/2}	317,500	360	715	400	360	120	1040	870	220	50	42	M36	620	244	30	23268..-K	H3268-HGX1208	
12 ^{15/16}	328,613	320	631	370	330	115	880	750	200	50	42	M36	540	198	23	23072..-K	H3072-HGX1215	
13	330,200	380	755	430	390	125	1120	950	240	60	48	M42	650	220	30	22272..-K	H3172-HGX1300	
13	330,200	320	631	370	330	115	880	750	200	50	42	M36	540	198	23	23072..-K	H3072-HGX1300	
13 ^{7/16}	341,313	320	631	370	330	115	880	750	200	50	42	M36	540	198	23	23072..-K	H3072-HGX1307	
13 ^{7/16}	341,313	350	695	400	360	120	1000	840	220	50	42	M36	600	212	30	23172..-K	H3172-HGX1307	
13 ^{7/16}	341,313	380	755	430	390	125	1120	950	240	60	48	M42	650	252	30	23272..-K	H3272-HGX1307	
13 ^{1/2}	342,900	380	755	430	390	125	1120	950	240	60	48	M42	650	220	30	22272..-K	H3172-HGX1308	
13 ^{1/2}	342,900	320	631	370	330	115	880	750	200	50	42	M36	540	198	23	23072..-K	H3072-HGX1308	
13 ^{1/2}	342,900	350	695	400	360	120	1000	840	220	50	42	M36	600	212	30	23172..-K	H3172-HGX1308	
13 ^{1/2}	342,900	380	755	430	390	125	1120	950	240	60	48	M42	650	252	30	23272..-K	H3272-HGX1308	
13 ^{1/2}	342,900	380	755	430	390	125	1120	950	240	60	48	M42	650	252	30	2325.1308 ¹⁾	–	
13 ^{15/16}	354,013	340	675	400	360	120	950	810	220	50	42	M36	560	180	24	23076..-K	H3076-HGX1315	
13 ^{15/16}	354,013	360	715	400	360	120	1040	870	220	50	42	M36	620	214	30	23176..-K	H3176-HGX1315	
13 ^{15/16}	354,013	410	810	460	420	130	1170	1000	260	60	48	M42	680	260	35	23276..-K	H3276-HGX1315	
14	355,600	340	675	400	360	120	950	810	220	50	42	M36	560	180	24	23076..-K	H3076-HGX1400	
14	355,600	340	675	400	360	120	950	810	220	50	42	M36	560	180	24	2305.1400	–	
14	355,600	360	715	400	360	120	1040	870	220	50	42	M36	620	214	30	23176..-K	H3176-HGX1400	
14	355,600	360	715	400	360	120	1040	870	220	50	42	M36	620	214	30	2315.1400 ¹⁾	–	
14	355,600	410	810	460	420	130	1170	1000	260	60	48	M42	680	260	35	23276..-K	H3276-HGX1400	
15	381,000	350	695	400	360	120	1000	840	220	50	42	M36	600	192	30	23080..-K	H3080-HGX1500	
15	381,000	380	755	430	390	125	1120	950	240	60	48	M42	650	220	30	23180..-K	H3180-HGX1500	
15	381,000	380	755	430	390	125	1120	950	240	60	48	M42	650	220	30	2315.1500 ¹⁾	–	
15	381,000	420	835	460	430	135	1220	1030	260	60	48	M42	720	276	35	23280..-K	H3280-HGX1500	

① Locating bearing; ② Non-locating bearing

¹⁾ Split bearing in associated housing has restricted usability. Please ask for further information.

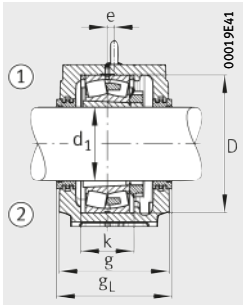

Labyrinth seal NTS

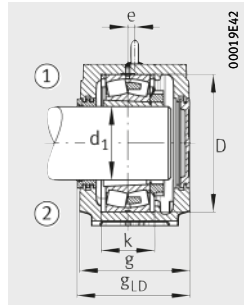

Labyrinth seal NTS
Cover NDK

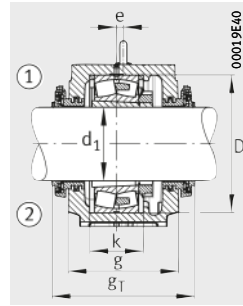

Taconite seal NTC

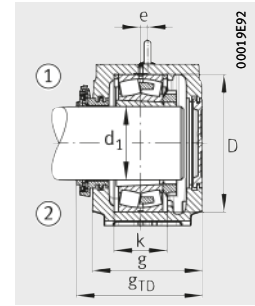

Taconite seal NTC
Cover NDK



								Housing			
Locating ring		Labyrinth seal			Taconite seal			Cover	G	Mass m ≈ kg	Designation
	Quantity		g _L mm	g _{LD} mm		g _T mm	g _{TD} mm				
NFR520/16	4	NTS68X1208	381	375,5	NTC68X1208	460	415	NDK68	M30	386	SNS3068-H-D
NFR580/10	2	NTS68X1208	411	405,5	NTC68X1208	490	445	NDK68	M30	461	SNS3168-H-D
NFR580/10	2	NTS68X1208	411	405,5	NTC68X1208	490	445	NDK68	M30	461	SNS3168-H-D
NFR620/10	2	NTS76X1208	411	405,5	NTC76X1208	490	445	NDK76	M36	530	SNS3268-H-D
NFR540/16	4	NTS72X1215	381	375,5	NTC72X1215	460	415	NDK72	M30	356	SNS3072-H-D
NFR650/25	2	NTS80X1300	441	435,5	NTC80X1300	520	475	NDK80	M42	681	SNS3180-H-D
NFR540/16	4	NTS72X1300	381	375,5	NTC72X1300	460	415	NDK72	M30	356	SNS3072-H-D
NFR540/16	4	NTS72X1307	381	375,5	NTC72X1307	460	415	NDK72	M30	356	SNS3072-H-D
NFR600/10	2	NTS72X1307	411	405,5	NTC72X1307	490	445	NDK72	M36	498	SNS3172-H-D
NFR650/10	2	NTS80X1307	441	435,5	NTC80X1307	520	475	NDK80	M42	675	SNS3272-H-D
NFR650/25	2	NTS80X1308	441	435,5	NTC80X1308	520	475	NDK80	M42	681	SNS3180-H-D
NFR540/16	4	NTS72X1308	381	375,5	NTC72X1308	460	415	NDK72	M30	356	SNS3072-H-D
NFR600/10	2	NTS72X1308	411	405,5	NTC72X1308	490	445	NDK72	M36	498	SNS3172-H-D
NFR650/10	2	NTS80X1308	441	435,5	NTC80X1308	520	475	NDK80	M42	675	SNS3272-H-D
NFR650/10	2	NTS80X1308	441	435,5	NTC80X1308	520	475	NDK80	M42	675	SNS3272-H-D
NFR560/22,5	2	NTS76X1315	411	405,5	NTC76X1315	490	445	NDK76	M30	481	SNS3076-H-D
NFR620/10	2	NTS76X1315	411	405,5	NTC76X1315	490	445	NDK76	M36	534	SNS3176-H-D
NFR680/10	2	NTS92X1315	471	465,5	NTC92X1315	550	505	NDK92	M42	841	SNS3276-H-D
NFR560/22,5	2	NTS76X1400	411	405,5	NTC76X1400	490	445	NDK76	M30	481	SNS3076-H-D
NFR560/22,5	2	NTS76X1400	411	405,5	NTC76X1400	490	445	NDK76	M30	481	SNS3076-H-D
NFR620/10	2	NTS76X1400	411	405,5	NTC76X1400	490	445	NDK76	M36	534	SNS3176-H-D
NFR620/10	2	NTS76X1400	411	405,5	NTC76X1400	490	445	NDK76	M36	534	SNS3176-H-D
NFR620/10	2	NTS76X1400	411	405,5	NTC76X1400	490	445	NDK76	M36	534	SNS3176-H-D
NFR680/10	2	NTS92X1400	471	465,5	NTC92X1400	550	505	NDK92	M42	841	SNS3276-H-D
NFR600/22	2	NTS80X1500	411	405,5	NTC80X1500	490	445	NDK80	M36	489	SNS3080-H-D
NFR650/10	2	NTS80X1500	441	435,5	NTC80X1500	520	475	NDK80	M42	681	SNS3180-H-D
NFR650/10	2	NTS80X1500	441	435,5	NTC80X1500	520	475	NDK80	M42	681	SNS3180-H-D
NFR720/10	2	NTS88X1500	471	465,5	NTC88X1500	550	505	NDK88	M42	895	SNS3280-H-D

Plummer block housings

SNS, split
 For spherical roller bearings with tapered bore and adapter sleeve
 Inch size shaft

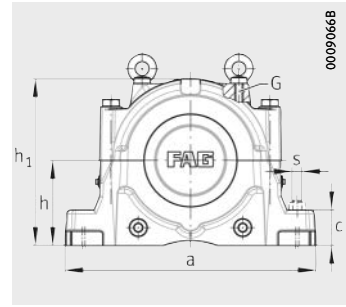
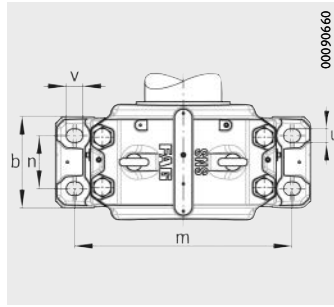

Dimension table (continued) · Dimensions in mm

Shaft d ₁		Housing Dimensions														Spherical roller bearing and accessories	
		h	h ₁	g	b	c	a	m	n	v	u	s	D	k	e	Bearing	Adapter sleeve
<i>inch</i>	mm																
15³/₄	400,050	360	715	400	360	120	1 040	870	220	50	42	M36	620	194	30	23084..-K	H3084X-HGX1512
15³/₄	400,050	410	810	460	420	130	1 170	1 000	260	60	48	M42	700	244	35	23184..-K	H3184-HGX1512
15³/₄	400,050	440	880	470	440	145	1 280	1 070	260	60	48	M42	760	292	35	23284..-K	H3284-HGX1512
16¹/₂	419,100	380	755	430	390	125	1 120	950	240	60	48	M42	650	200	30	23088..-K	H3088-HGX1608
16¹/₂	419,100	380	755	430	390	125	1 120	950	240	60	48	M42	650	200	30	2305.1608	–
16¹/₂	419,100	420	835	460	430	135	1 220	1 030	260	60	48	M42	720	246	35	23188..-K	H3188-HGX1608
16¹/₂	419,100	460	920	470	440	155	1 330	1 110	260	70	56	M48	790	300	35	23288..-K	H3288-HGX1608
17	431,800	410	810	460	420	130	1 170	1 000	260	60	48	M42	680	224	35	23092..-K	H3092-HGX1700
17	431,800	440	880	470	440	145	1 280	1 070	260	60	48	M42	760	260	35	23192..-K	H3192-HGX1700
18	457,200	410	810	460	420	130	1 170	1 000	260	60	48	M42	700	224	35	23096..-K	H3096-HGX1800
18	457,200	460	920	470	440	155	1 330	1 110	260	70	56	M48	790	268	35	23196..-K	H3196-HGX1800
18¹/₂	469,900	420	835	460	430	135	1 220	1 030	260	60	48	M42	720	226	35	230/500..-K	H30/500-HGX1808
19¹/₂	495,300	460	920	470	440	155	1 330	1 110	260	70	56	M48	780	248	35	230/530..-K	H30/530-HGX1908

① Locating bearing; ② Non-locating bearing

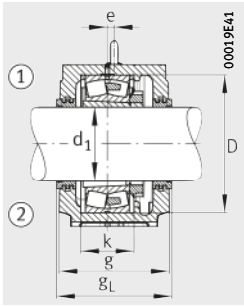

Labyrinth seal NTS

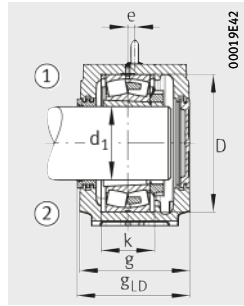

Labyrinth seal NTS
Cover NDK

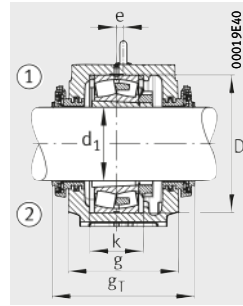

Tacanite seal NTC

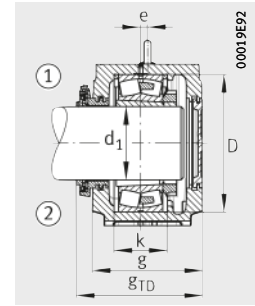

Tacanite seal NTC
Cover NDK



								Housing			
Locating ring		Labyrinth seal			Tacanite seal			Cover	G	Mass m ≈ kg	Designation
	Quantity		g _L mm	g _{LD} mm		g _T mm	g _{TD} mm				
NFR620/22	2	NTS84X1512	411	405,5	NTC84X1512	490	445	NDK84	M36	527	SNS3084-H-D
NFR700/10	2	NTS84X1512	471	465,5	NTC84X1512	550	505	NDK84	M42	821	SNS3184-H-D
NFR760/10	2	NTS92X1512	481	475,5	NTC92X1512	560	515	NDK92	M48	984	SNS3284-H-D
NFR650/21,5	2	NTS88X1608	441	435,5	NTC88X1608	520	475	NDK88	M42	672	SNS3088-H-D
NFR650/21,5	2	NTS88X1608	441	435,5	NTC88X1608	520	475	NDK88	M42	672	SNS3088-H-D
NFR720/10	2	NTS88X1608	471	465,5	NTC88X1608	550	505	NDK88	M42	895	SNS3188-H-D
NFR790/10	2	NTS96X1608	481	475,5	NTC96X1608	560	515	NDK96	M48	1 100	SNS3288-H-D
NFR680/30,5	2	NTS92X1700	471	465,5	NTC92X1700	550	505	NDK92	M42	849	SNS3092-H-D
NFR760/10	2	NTS92X1700	481	475,5	NTC92X1700	560	515	NDK92	M48	993	SNS3192-H-D
NFR700/29,5	2	NTS96X1800	471	465,5	NTC96X1800	550	505	NDK96	M42	806	SNS3096-H-D
NFR790/10	2	NTS96X1800	481	475,5	NTC96X1800	560	515	NDK96	M48	1 100	SNS3196-H-D
NFR720/29,5	2	NTS500X1808	471	465,5	NTC500X1808	550	505	NDK500	M42	895	SNS30/500-H-D
NFR780/31,5	2	NTS530X1908	481	475,5	NTC530X1908	560	515	NDK530	M48	1 100	SNS30/530-H-D

Plummer block housings

SNS, split
 For spherical roller bearings with tapered bore and adapter sleeve
 Metric shaft
 Bolt-on design

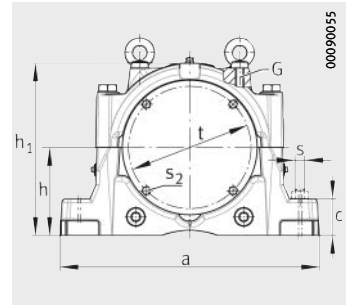
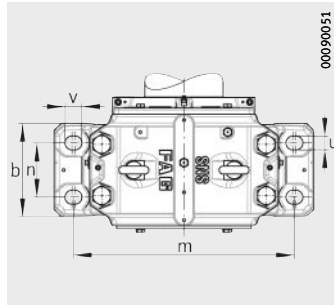

Dimension table - Dimensions in mm

Shaft d_1	Housing Dimensions																	Spherical roller bearing and accessories	
	h	h_1	g	b	c	a	m	n	v	u	s	D_2	D	k	e	t	s_2	Quantity	Bearing
150	170	333	219	180	70	510	430	100	34	28	M24	210	280	108	14	240	M8	4	23134..-K
150	170	333	219	180	70	510	430	100	34	28	M24	210	280	108	14	240	M8	4	231SM150-MA ¹⁾
160	180	353	226	190	75	530	450	110	34	28	M24	220	300	116	15	250	M10	4	23136..-K
160	180	353	226	190	75	530	450	110	34	28	M24	220	300	116	15	250	M10	4	231SM160-MA ¹⁾
170	190	375	246	210	80	560	480	120	34	28	M24	230	320	124	10	266	M8	4	23138..-K
170	190	375	246	210	80	560	480	120	34	28	M24	230	320	124	10	266	M8	4	231SM170-MA
180	210	411	266	230	85	610	510	130	42	35	M30	250	340	132	10	286	M8	4	23140..-K
180	210	411	266	230	85	610	510	130	42	35	M30	250	340	132	10	286	M8	4	231SM180-MA
200	220	434	278	240	90	640	540	140	42	35	M30	270	370	140	12	310	M10	4	23144..-K
200	220	434	278	240	90	640	540	140	42	35	M30	270	370	140	12	310	M10	4	231SM200-MA ¹⁾
220	240	474	300	260	95	700	600	150	42	35	M30	300	400	148	12	336	M10	4	23148..-K
220	240	474	300	260	95	700	600	150	42	35	M30	300	400	148	12	336	M10	4	231SM220-MA
240	260	516	310	280	100	770	650	160	50	42	M36	320	440	164	13	356	M10	4	23152..-K
240	260	516	310	280	100	770	650	160	50	42	M36	320	440	164	13	356	M10	4	231SM240-MA ¹⁾
260	280	550	310	280	105	790	670	160	50	42	M36	340	460	166	16	380	M10	4	23156..-K
260	280	550	310	280	105	790	670	160	50	42	M36	340	460	166	16	380	M10	4	231SM260-MA
280	300	591	340	310	110	830	710	190	50	42	M36	355	500	180	22	412	M10	8	23160..-K
280	300	591	340	310	110	830	710	190	50	42	M36	355	500	180	22	412	M10	8	231SM280-MA ¹⁾
300	320	631	360	330	115	880	750	200	50	42	M36	380	540	196	23	436	M10	8	23164..-K
300	320	631	360	330	115	880	750	200	50	42	M36	380	540	196	23	436	M10	8	231SM300-MA ¹⁾
320	340	675	392	360	120	950	810	220	50	42	M36	400	580	210	24	468	M10	8	23168..-K
320	340	675	392	360	120	950	810	220	50	42	M36	400	580	210	24	468	M10	8	231SM320-MA

① Locating bearing; ② Non-locating bearing

¹⁾ Split bearing in associated housing has restricted usability.
 Please ask for further information.

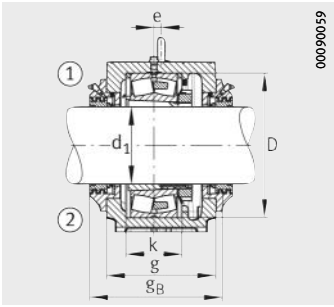

Bolt-on seal BTAC

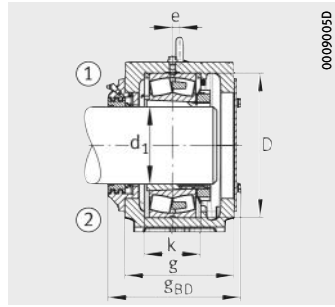

Bolt-on seal BTAC
Cover BDK

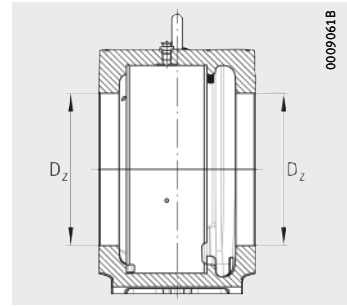

							Housing		
Adapter sleeve	Locating ring		Bolt-on seal			Cover	G	Mass m ≈ kg	Designation
		Quantity		g _B mm	g _{BD} mm				
H3134(-HG)	NFR280/10	2	BTAC34	289	268	BDK34	M16	70	SNS3134-B-D
–	NFR280/10	2	BTAC34	289	268	BDK34	M16	70	SNS3134-B-D
H3136(-HG)	NFR300/10	2	BTAC36	296	275	BDK36	M16	78	SNS3136-B-D
–	NFR300/10	2	BTAC36	296	275	BDK36	M16	78	SNS3136-B-D
H3138(-HG)	NFR320/10	2	BTAC38	316	295	BDK38	M20	96	SNS3138-B-D
–	NFR320/10	2	BTAC38	316	295	BDK38	M20	96	SNS3138-B-D
H3140(-HG)	NFR340/10	2	BTAC40	336	315	BDK40	M20	123	SNS3140-B-D
–	NFR340/10	2	BTAC40	336	315	BDK40	M20	123	SNS3140-B-D
H3144X(-HG)	NFR370/10	2	BTAC44	348	327	BDK44	M20	137	SNS3144-B-D
–	NFR370/10	2	BTAC44	348	327	BDK44	M20	137	SNS3144-B-D
H3148X(-HG)	NFR400/10	2	BTAC48	378	353	BDK48	M24	173	SNS3148-B-D
–	NFR400/10	2	BTAC48	378	353	BDK48	M24	173	SNS3148-B-D
H3152X(-HG)	NFR440/10	2	BTAC52	392	365	BDK52	M24	226	SNS3152-B-D
–	NFR440/10	2	BTAC52	392	365	BDK52	M24	226	SNS3152-B-D
H3156X(-HG)	NFR460/10	2	BTAC56	392	365	BDK56	M24	252	SNS3156-B-D
–	NFR460/10	2	BTAC56	392	365	BDK56	M24	252	SNS3156-B-D
H3160(-HG)	NFR500/10	2	BTAC60	422	395	BDK60	M30	305	SNS3160-B-D
–	NFR500/10	2	BTAC60	422	395	BDK60	M30	305	SNS3160-B-D
H3164-HG	NFR540/10	2	BTAC64	442	415	BDK64	M30	354	SNS3164-B-D
–	NFR540/10	2	BTAC64	442	415	BDK64	M30	354	SNS3164-B-D
H3168-HG	NFR580/10	2	BTAC68	480	450	BDK68	M30	446	SNS3168-B-D
–	NFR580/10	2	BTAC68	480	450	BDK68	M30	446	SNS3168-B-D

FAG

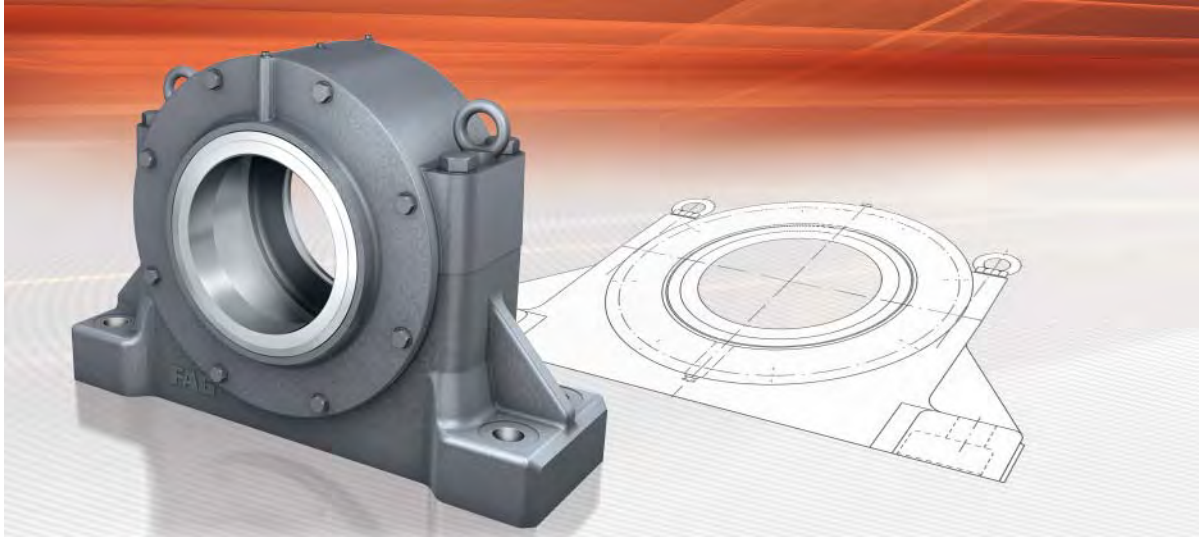

Split plummer block housings RLE

Split plummer block housings RLE

		Page
Product overview	Split plummer block housings RLE	216
Features	Suitable bearings	217
	Housing materials and anti-corrosion protection	217
	Locating and non-locating bearings	217
	Seals and covers	218
	Housing configurations.....	219
	Lubrication	220
	Designation structure	221
	Ordering examples	222
Design and safety guidelines	Eye bolts	223
	Foot screws	223
Accuracy	223
Dimension tables	Plummer block housings RLE, split, for spherical roller bearings with tapered bore and withdrawal sleeve.....	224
	Plummer block housings RLE, split, for spherical roller bearings with cylindrical bore, stepped shaft.....	226



Product overview Split plummer block housings RLE

Plummer block housings

Split

Closed on one side, with cover

RLE...AF, RLE...AL



0001ACE2

For continuous shaft

RLE...BF, RLE...BL



00081EC9

Split plummer block housings RLE

Features Split plummer block housings RLE were developed specifically for the bearing arrangements of back-up rollers.

Suitable bearings The dimensions of split plummer block housings RLE are matched to spherical roller bearings 241, see table. The range of shaft diameters is between 180 mm and 500 mm.

Bearing type and sizes

Bearing type	Size
Spherical roller bearings	24122...-K30 to 241/500...-K30
■ with tapered bore and withdrawal sleeve	
■ with cylindrical bore	24122 to 241/500

Housing materials and anti-corrosion protection

The standard material for the housing bodies is flake graphite cast iron (suffix L). By agreement, housing bodies made from spheroidal graphite cast iron (suffix D) or cast steel (suffix S) are available.

All outer surfaces not machined by chip-forming methods have a universal paint coating (colour RAL 7031, bluish-grey). The coating can be finished using all synthetic resin, polyurethane, acrylic, epoxy resin, chlorinated rubber, nitrocellulose and acid-hardening hammer tone finishes.

Inner and outer surfaces machined by chip-forming methods are provided with anti-corrosion protection that can be easily removed. It is recommended that only volatile solvents and lint-free cloths should be used.

Locating and non-locating bearings

The housings are supplied as a locating bearing design or non-locating bearing design. In the locating bearing, the bearing is clamped between the housing covers. In the non-locating bearing, the bearing can align itself axially, since the covers have shorter centring collars.



Split plummer block housings RLE

Seals and covers

Plummer block housings RLE of design A are intended for the bearing arrangements of shaft ends. One side is closed by a cover and the other side is sealed against the shaft. Design B is intended for continuous shafts, in which case the housing is sealed against the shaft on both sides.

The seal is a combination of a labyrinth seal and a felt seal, *Figure 1*. The labyrinth is separated from the grease cavity in the housing by oil-soaked felt strips, so a more economical grease can be used for labyrinth lubrication.

The labyrinth rings are unsplit. The seal allows shaft misalignment of up to $0,5^\circ$ in both directions.

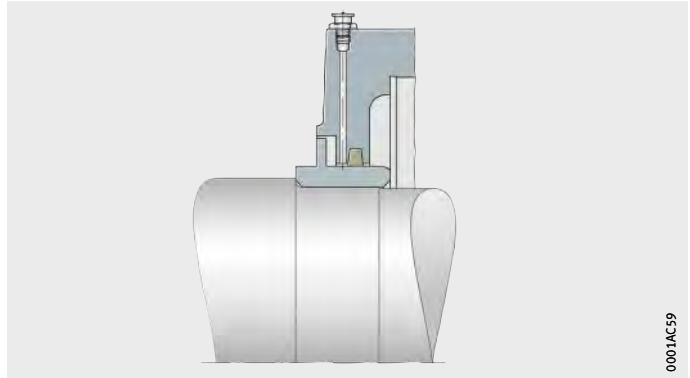

Figure 1
Labyrinth with felt seal
for plummer block housing RLE

Housing configurations

In the case of plummer block housings RLE, various housing configurations are possible that are clearly described by means of the designation, *Figure 2 to Figure 5*, page 220.

The following features can be varied in the housing configuration:

- location of bearings with a tapered bore by means of a withdrawal sleeve on a shaft of constant diameter or of bearings with a cylindrical bore directly on a stepped shaft
- continuous shaft or a housing closed on one side
- design of the bearing arrangement as a locating bearing arrangement or a non-locating bearing arrangement.



- ① Locating bearing RLE...AH-AF
- ② Non-locating bearing RLE...AH-AL

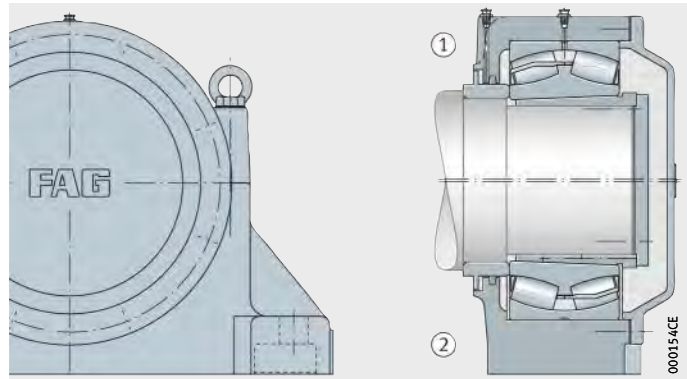

Figure 2
Plummer block housing RLE
for bearings with tapered bore and
withdrawal sleeve, design A

- ① Locating bearing RLE...AH-BF
- ② Non-locating bearing RLE...AH-BL

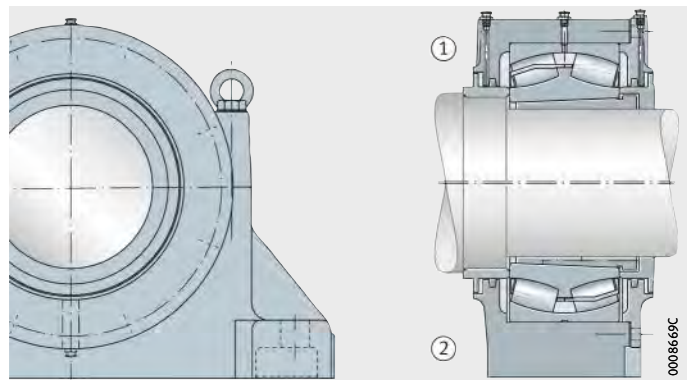
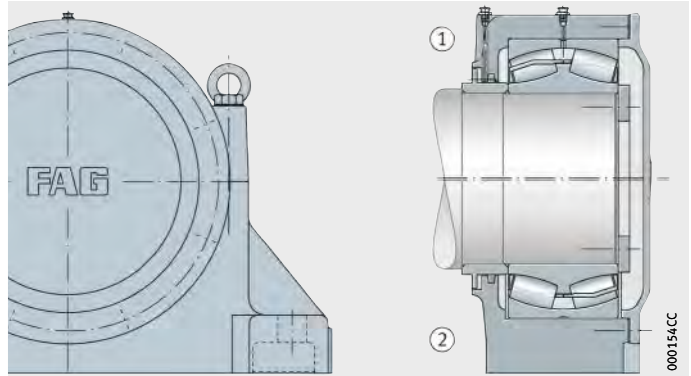

Figure 3
Plummer block housing RLE
for bearings with tapered bore and
withdrawal sleeve, design B

Split plummer block housings RLE

- ① Locating bearing RLE..-Z-AF
- ② Non-locating bearing RLE..-Z-AL

Figure 4
Plummer block housing RLE
for bearings with cylindrical bore,
design A



- ① Locating bearing RLE..-Z-BF
- ② Non-locating bearing RLE..-Z-BL

Figure 5
Plummer block housing RLE
for bearings with cylindrical bore,
design B

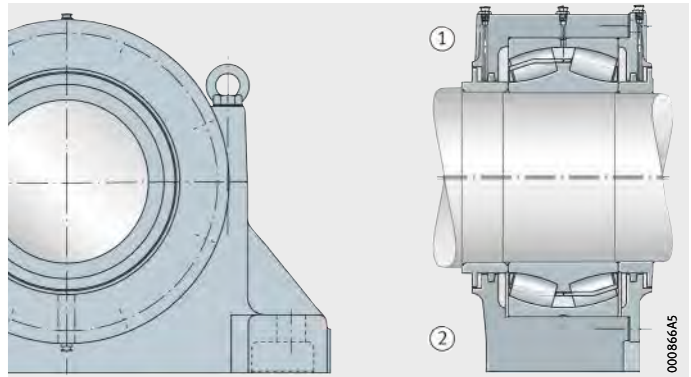

Lubrication

Split plummer block housings RLE are designed for grease lubrication.

Relubrication

The housings have button head lubrication nipples to DIN 3404-M10×1. The lubrication nipple in the centre of the housing is intended for relubrication of the bearing. The grease is fed uniformly to both rows of rollers via the circumferential slot and three lubrication holes in the outer ring of the spherical roller bearings. The outer lubrication nipples are intended for relubrication of the labyrinth seals.

Designation structure

The designation structure for split plummer block housings RLE is shown in the table and *Figure 6*.

Designation structure of plummer block housings RLE

Feature	Code	Description
① Series	RLE	Split plummer block housings RLE
② ISO dimension series of bearing	41	ISO dimension series 41
③ Bore code of bearing	68	Bore code, two digits: ■ bore diameter (68 · 5) mm = 340 mm
	/500	Bore code, three digits: ■ bore diameter 500 mm
④ Bearing bore	AH	Tapered bearing bore and withdrawal sleeve
	Z	Cylindrical bearing bore
⑤ Housing design	AF	Closed on one side, locating bearing
	AL	Closed on one side, non-locating bearing
	BF	Continuous shaft, locating bearing
	BL	Continuous shaft, non-locating bearing
⑥ Housing material	L	Flake graphite cast iron (standard)
	D	Spheroidal graphite cast iron
	S	Cast steel



Figure 6
Designation structure of plummer block housings RLE, example



Split plummer block housings RLE

Ordering examples

When ordering a split plummer block housing RLE, the designation contains indications of the size and location method of the bearing as well as the design and material of the housing. The rolling bearing and, if necessary, the withdrawal sleeve must be ordered separately. The ordering examples show the construction of orders for selected housing combinations and the appropriate bearings. The allocation of housings, bearings and withdrawal sleeves for all housing sizes is shown in the dimension tables.

Example 1 Plummer block housing RLE made from flake graphite cast iron, for continuous shaft, spherical roller bearing 24180-B-K30 as non-locating bearing, location using withdrawal sleeve.

Order 1 plummer block housing RLE4180-AH-BL-L
1 spherical roller bearing 24180-B-K30
1 withdrawal sleeve AH24180-H

Example 2 Plummer block housing RLE made from flake graphite cast iron, closed on one side, spherical roller bearing 24180-B as locating bearing.

Order 1 plummer block housing RLE24180-Z-AF-L
1 spherical roller bearing 24180-B

Design and safety guidelines

Eye bolts

The upper housing section has 2 eye bolts in accordance with DIN 580. These are intended as locating points for mounting and dismantling of the housing. The load carrying capacity of the eye bolts allows lifting of the housing including a bearing fitted in the housing.



Eye bolts must always be screwed fully into the housing. The eye bolt must not be subjected to a mass greater than that of the housing together with the bearing fitted in the housing.

Foot screws

Foot screws are used for screw mounting of the housing to the locating surface. They are not included in the scope of delivery of the housings.

The appropriate screw size for each housing is stated, see dimension tables.

The associated tightening torques are stated for screws with a metric thread in accordance with DIN 13, DIN 962 and DIN ISO 965-2, see table, page 42.

Accuracy

The bearing seat in split plummer block housings RLE is machined to the tolerance class H7.

By agreement, the housings can also be supplied with other tolerance classes for the bearing seat, see section Tolerance class of bearing seat, page 47.



Plummer block housings

RLE, split
 For spherical roller bearings with tapered bore and withdrawal sleeve
 Stepped shaft

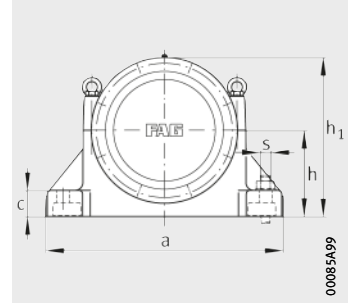
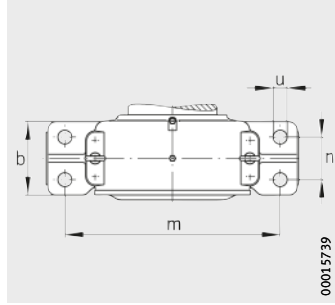

Dimension table - Dimensions in mm

Shaft				Housing Dimensions										
d ₁	d ₂	d ₃	d ₄	h	h ₁	g ₂	g ₅	e	k	k ₁	b	c	a	m
		max.												
180	192	198	175	225	412	–	272	15	1	4	180	70	600	510
180	192	198	175	225	412	240	–	15	1	4	180	70	600	510
190	202	212	185	240	442	–	287	15	1	4	195	75	690	580
190	202	212	185	240	442	260	–	15	1	4	195	75	690	580
200	222	232	195	260	477	–	307	15	1	4	210	80	720	610
200	222	232	195	260	477	270	–	15	1	4	210	80	720	610
220	242	252	215	280	517	–	323	15	1	5	225	85	770	655
220	242	252	215	280	517	280	–	15	1	5	225	85	770	655
240	262	272	235	310	567	–	350	15	1	5	250	95	860	730
240	262	272	235	310	567	315	–	15	1	5	250	95	860	730
260	282	292	255	320	587	–	350	15	2	5	250	100	880	750
260	282	292	255	320	587	315	–	15	2	5	250	100	880	750
280	302	315	275	350	642	–	386	15	2	5	280	110	940	800
280	302	315	275	350	642	335	–	15	2	5	280	110	940	800
300	322	335	295	380	697	–	421	20	2	5	305	120	1060	900
300	322	335	295	380	697	370	–	20	2	5	305	120	1060	900
320	342	355	315	410	752	–	480	20	2	5	340	130	1110	940
320	342	355	315	410	752	405	–	20	2	5	340	130	1110	940
340	362	375	335	430	792	–	480	20	2	5	340	135	1190	1010
340	362	375	335	430	792	405	–	20	2	5	340	135	1190	1010
360	382	395	355	430	792	–	490	20	2	5	340	140	1190	1010
360	382	395	355	430	792	405	–	20	2	5	340	140	1190	1010
380	402	415	375	450	827	–	500	20	2	5	350	145	1230	1040
380	402	415	375	450	827	415	–	20	2	5	350	145	1230	1040
400	422	435	395	490	897	–	555	20	2	5	390	155	1300	1110
400	422	435	395	490	897	455	–	20	2	5	390	155	1300	1110
420	442	455	415	500	917	–	555	20	2	5	390	155	1370	1165
420	442	455	415	500	917	455	–	20	2	5	390	155	1370	1165
440	462	475	435	530	972	–	595	25	2	6	420	160	1500	1270
440	462	475	435	530	972	495	–	25	2	6	420	160	1500	1270
460	482	495	455	550	1012	–	610	25	2	6	430	165	1530	1300
460	482	495	455	550	1012	500	–	25	2	6	430	165	1530	1300
480	502	515	475	550	1032	–	630	25	2	6	450	180	1580	1300
480	502	515	475	550	1032	520	–	25	2	6	450	180	1580	1300

① Locating bearing AF; ② Non-locating bearing AL; ③ Locating bearing BF; ④ Non-locating bearing BL

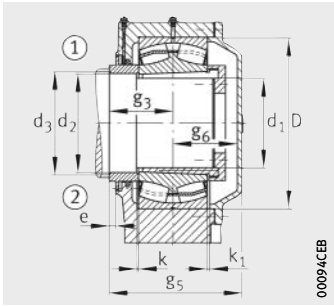

Design A

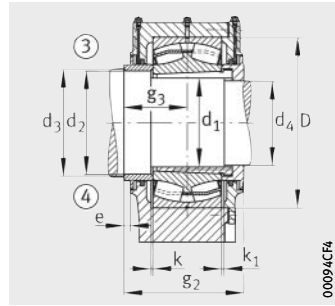

Design B



						Spherical roller bearing and accessories		Housing		
n	u	s	D	g ₃	g ₆ min.	Bearing	Withdrawal sleeve	Mass m ≈ kg	Designation	
									Locating bearing	Non-locating bearing
100	36	M30	320	127	137	24138..-K30	AH24138	115	RLE4138..-AH-AF	RLE4138..-AH-AL
100	36	M30	320	127	137	24138..-K30	AH24138	115	RLE4138..-AH-BF	RLE4138..-AH-BL
105	42	M36	340	137	142	24140..-K30	AH24140	145	RLE4140..-AH-AF	RLE4140..-AH-AL
105	42	M36	340	137	142	24140..-K30	AH24140	145	RLE4140..-AH-BF	RLE4140..-AH-BL
120	42	M36	370	142	155	24144..-K30	AH24144(-H)	175	RLE4144..-AH-AF	RLE4144..-AH-AL
120	42	M36	370	142	155	24144..-K30	AH24144(-H)	175	RLE4144..-AH-BF	RLE4144..-AH-BL
130	42	M36	400	148	165	24148..-K30	AH24148(-H)	220	RLE4148..-AH-AF	RLE4148..-AH-AL
130	42	M36	400	148	165	24148..-K30	AH24148(-H)	220	RLE4148..-AH-BF	RLE4148..-AH-BL
140	49	M42	440	165	175	24152..-K30	AH24152(-H)	295	RLE4152..-AH-AF	RLE4152..-AH-AL
140	49	M42	440	165	175	24152..-K30	AH24152(-H)	295	RLE4152..-AH-BF	RLE4152..-AH-BL
145	49	M42	460	165	175	24156..-K30	AH24156(-H)	320	RLE4156..-AH-AF	RLE4156..-AH-AL
145	49	M42	460	165	175	24156..-K30	AH24156(-H)	320	RLE4156..-AH-BF	RLE4156..-AH-BL
165	49	M42	500	176	198	24160..-K30	AH24160(-H)	415	RLE4160..-AH-AF	RLE4160..-AH-AL
165	49	M42	500	176	198	24160..-K30	AH24160(-H)	415	RLE4160..-AH-BF	RLE4160..-AH-BL
170	56	M48	540	196	213	24164..-K30	AH24164-H	550	RLE4164..-AH-AF	RLE4164..-AH-AL
170	56	M48	540	196	213	24164..-K30	AH24164-H	550	RLE4164..-AH-BF	RLE4164..-AH-BL
195	56	M48	580	210	258	24168..-K30	AH24168-H	685	RLE4168..-AH-AF	RLE4168..-AH-AL
195	56	M48	580	210	258	24168..-K30	AH24168-H	685	RLE4168..-AH-BF	RLE4168..-AH-BL
195	56	M48	600	210	258	24172..-K30	AH24172-H	765	RLE4172..-AH-AF	RLE4172..-AH-AL
195	56	M48	600	210	258	24172..-K30	AH24172-H	765	RLE4172..-AH-BF	RLE4172..-AH-BL
195	68	M56	620	210	265	24176..-K30	AH24176-H	775	RLE4176..-AH-AF	RLE4176..-AH-AL
195	68	M56	620	210	265	24176..-K30	AH24176-H	775	RLE4176..-AH-BF	RLE4176..-AH-BL
200	68	M56	650	215	270	24180..-K30	AH24180-H	870	RLE4180..-AH-AF	RLE4180..-AH-AL
200	68	M56	650	215	270	24180..-K30	AH24180-H	870	RLE4180..-AH-BF	RLE4180..-AH-BL
225	68	M56	700	232	308	24184..-K30	AH24184-H	1 100	RLE4184..-AH-AF	RLE4184..-AH-AL
225	68	M56	700	232	308	24184..-K30	AH24184-H	1 100	RLE4184..-AH-BF	RLE4184..-AH-BL
225	68	M56	720	232	308	24188..-K30	AH24188-H	1 150	RLE4188..-AH-AF	RLE4188..-AH-AL
225	68	M56	720	232	308	24188..-K30	AH24188-H	1 150	RLE4188..-AH-BF	RLE4188..-AH-BL
240	76	M64	760	252	328	24192..-K30	AH24192-H	1 400	RLE4192..-AH-AF	RLE4192..-AH-AL
240	76	M64	760	252	328	24192..-K30	AH24192-H	1 400	RLE4192..-AH-BF	RLE4192..-AH-BL
245	76	M64	790	256	338	24196..-K30	AH24196-H	1 550	RLE4196..-AH-AF	RLE4196..-AH-AL
245	76	M64	790	256	338	24196..-K30	AH24196-H	1 550	RLE4196..-AH-BF	RLE4196..-AH-BL
260	76	M64	830	265	350	241/500..-K30	AH241/500-H	1 600	RLE41/500..-AH-AF	RLE41/500..-AH-AL
260	76	M64	830	265	350	241/500..-K30	AH241/500-H	1 600	RLE41/500..-AH-BF	RLE41/500..-AH-BL

Plummer block housings

RLE, split
For spherical roller bearings with cylindrical bore
Stepped shaft

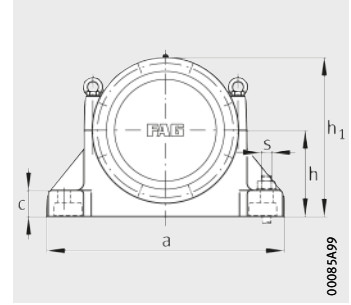
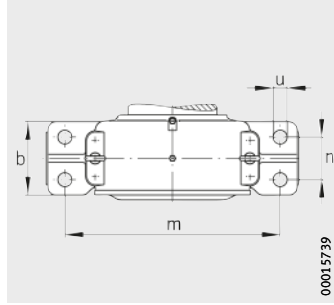

Dimension table - Dimensions in mm

Shaft				Housing Dimensions										
d	d ₂	d ₃ max.	d ₄	h	h ₁	g ₁	g ₂	e	k	k ₁	b	c	a	m
190	192	198	175	225	412	230	-	15	1	4	180	70	600	510
190	192	198	175	225	412	-	240	15	1	4	180	70	600	510
200	202	212	185	240	442	250	-	15	1	4	195	75	690	580
200	202	212	185	240	442	-	260	15	1	4	195	75	690	580
220	222	232	195	260	477	265	-	15	1	4	210	80	720	610
220	222	232	195	260	477	-	270	15	1	4	210	80	720	610
240	242	252	215	280	517	275	-	15	1	5	225	85	770	655
240	242	252	215	280	517	-	280	15	1	5	225	85	770	655
260	262	272	235	310	567	305	-	15	1	5	250	95	860	730
260	262	272	235	310	567	-	315	15	1	5	250	95	860	730
280	282	292	255	320	587	305	-	15	2	5	250	100	880	750
280	282	292	255	320	587	-	315	15	2	5	250	100	880	750
300	302	315	275	350	642	335	-	15	2	5	280	110	940	800
300	302	315	275	350	642	-	335	15	2	5	280	110	940	800
320	322	335	295	380	697	365	-	20	2	5	305	120	1060	900
320	322	335	295	380	697	-	370	20	2	5	305	120	1060	900
340	342	355	315	410	752	400	-	20	2	5	340	130	1110	940
340	342	355	315	410	752	-	405	20	2	5	340	130	1110	940
360	362	375	335	430	792	400	-	20	2	5	340	135	1190	1010
360	362	375	335	430	792	-	405	20	2	5	340	135	1190	1010
380	382	395	355	430	792	400	-	20	2	5	340	140	1190	1010
380	382	395	355	430	792	-	405	20	2	5	340	140	1190	1010
400	402	415	375	450	827	410	-	20	2	5	350	145	1230	1040
400	402	415	375	450	827	-	415	20	2	5	350	145	1230	1040
420	422	435	395	490	897	450	-	20	2	5	390	155	1300	1110
420	422	435	395	490	897	-	455	20	2	5	390	155	1300	1110
440	442	455	415	500	917	450	-	20	2	5	390	155	1370	1165
440	442	455	415	500	917	-	455	20	2	5	390	155	1370	1165
460	462	475	435	530	972	485	-	25	2	6	420	160	1500	1270
460	462	475	435	530	972	-	495	25	2	6	420	160	1500	1270
480	482	495	455	550	1012	500	-	25	2	6	430	165	1530	1300
480	482	495	455	550	1012	-	500	25	2	6	430	165	1530	1300
500	502	515	475	550	1032	515	-	25	2	6	450	180	1580	1300
500	502	515	475	550	1032	-	520	25	2	6	450	180	1580	1300

① Locating bearing AF; ② Non-locating bearing AL; ③ Locating bearing BF; ④ Non-locating bearing BL

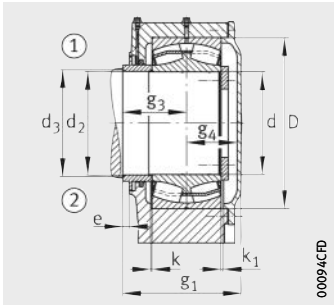

Design A

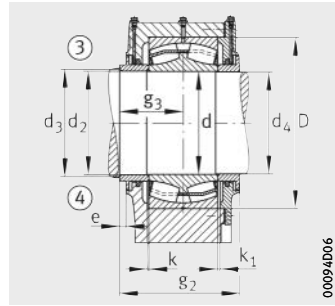

Design B



n	u	s	D	g ₃	g ₄ min.	Spherical roller bearing	Housing		
							Mass m ≈ kg	Designation	
								Locating bearing	Non-locating bearing
100	36	M30	320	127	95	24138	115	RLE4138..-Z-AF	RLE4138..-Z-AL
100	36	M30	320	127	95	24138	115	RLE4138..-Z-BF	RLE4138..-Z-BL
105	42	M36	340	137	105	24140	145	RLE4140..-Z-AF	RLE4140..-Z-AL
105	42	M36	340	137	105	24140	145	RLE4140..-Z-BF	RLE4140..-Z-BL
120	42	M36	370	142	113	24144	175	RLE4144..-Z-AF	RLE4144..-Z-AL
120	42	M36	370	142	113	24144	175	RLE4144..-Z-BF	RLE4144..-Z-BL
130	42	M36	400	148	117	24148	220	RLE4148..-Z-AF	RLE4148..-Z-AL
130	42	M36	400	148	117	24148	220	RLE4148..-Z-BF	RLE4148..-Z-BL
140	49	M42	440	165	130	24152	295	RLE4152..-Z-AF	RLE4152..-Z-AL
140	49	M42	440	165	130	24152	295	RLE4152..-Z-BF	RLE4152..-Z-BL
145	49	M42	460	165	130	24156	320	RLE4156..-Z-AF	RLE4156..-Z-AL
145	49	M42	460	165	130	24156	320	RLE4156..-Z-BF	RLE4156..-Z-BL
165	49	M42	500	176	147	24160	415	RLE4160..-Z-AF	RLE4160..-Z-AL
165	49	M42	500	176	147	24160	415	RLE4160..-Z-BF	RLE4160..-Z-BL
170	56	M48	540	196	157	24164	550	RLE4164..-Z-AF	RLE4164..-Z-AL
170	56	M48	540	196	157	24164	550	RLE4164..-Z-BF	RLE4164..-Z-BL
195	56	M48	580	210	178	24168	685	RLE4168..-Z-AF	RLE4168..-Z-AL
195	56	M48	580	210	178	24168	685	RLE4168..-Z-BF	RLE4168..-Z-BL
195	56	M48	600	210	178	24172	765	RLE4172..-Z-AF	RLE4172..-Z-AL
195	56	M48	600	210	178	24172	765	RLE4172..-Z-BF	RLE4172..-Z-BL
195	68	M56	620	210	175	24176	775	RLE4176..-Z-AF	RLE4176..-Z-AL
195	68	M56	620	210	175	24176	775	RLE4176..-Z-BF	RLE4176..-Z-BL
200	68	M56	650	215	180	24180	870	RLE4180..-Z-AF	RLE4180..-Z-AL
200	68	M56	650	215	180	24180	870	RLE4180..-Z-BF	RLE4180..-Z-BL
225	68	M56	700	232	203	24184	1 100	RLE4184..-Z-AF	RLE4184..-Z-AL
225	68	M56	700	232	203	24184	1 100	RLE4184..-Z-BF	RLE4184..-Z-BL
225	68	M56	720	232	203	24188	1 150	RLE4188..-Z-AF	RLE4188..-Z-AL
225	68	M56	720	232	203	24188	1 150	RLE4188..-Z-BF	RLE4188..-Z-BL
240	76	M64	760	252	218	24192	1 400	RLE4192..-Z-AF	RLE4192..-Z-AL
240	76	M64	760	252	218	24192	1 400	RLE4192..-Z-BF	RLE4192..-Z-BL
245	76	M64	790	256	228	24196	1 550	RLE4196..-Z-AF	RLE4196..-Z-AL
245	76	M64	790	256	228	24196	1 550	RLE4196..-Z-BF	RLE4196..-Z-BL
260	76	M64	830	265	235	241/500	1 600	RLE41/500..-Z-AF	RLE41/500..-Z-AL
260	76	M64	830	265	235	241/500	1 600	RLE41/500..-Z-BF	RLE41/500..-Z-BL

FAG



Split plummer block housings KPG, KPGZ

Split plummer block housings KPG, KPGZ

		Page
Product overview	Split plummer block housings KPG, KPGZ.....	230
Features	Demands on the trunnion bearing arrangement on converters	231
	Suitable bearings	231
	Housing materials and anti-corrosion protection	232
	Locating and non-locating bearings	232
	Seals.....	232
	Housing configurations.....	233
	Lubrication	235
	Designation structure	235
	Ordering examples	236
Design and safety guidelines	Eye bolts	237
	Foot screws	237
Accuracy	237
Dimension tables	Plummer block housings KPG, split, for spherical roller bearings with tapered bore and sleeve, for split spherical roller bearings.....	238
	Plummer block housings KPGZ, split, for spherical roller bearings with cylindrical bore, for split spherical roller bearings.....	242



Product overview Split plummer block housings KPG, KPGZ

Plummer block housings
Split
With high-pressure packing

KPG, KPGZ



Split plummer block housings KPG, KPGZ



Features

Split plummer block housings KPG and KPGZ were developed specifically for trunnion bearing arrangements on converters.

Demands on the trunnion bearing arrangement on converters

When filled, large converter drums weigh several hundred tonnes. The resulting loads must be supported by the trunnion bearing arrangement. As only slow swivel motions occur, the bearings must feature a high static load carrying capacity. In addition, shock loads must be accommodated daily in converters.

The bearing arrangement must also be able to compensate housing misalignments and deflections of the construction. These are in addition to considerable changes in length that arise due to temperature changes during the commissioning and decommissioning of the converter as well as geometrical changes in the support ring.

The spherical roller bearing has established itself as the principal rolling bearing type for converters. In addition to its high radial and axial load carrying capacity and its insensitivity to shocks, it also exhibits significant angular adjustability. Converter bearing arrangements are fitted with spherical roller bearings specifically developed for the application.

Suitable bearings

The dimensions of split plummer block housings KPG and KPGZ are matched to spherical roller bearings 249, see table. The housings KPG are intended for bearings with a tapered bore and adjustment sleeve, while the housings KPGZ are intended for bearings with a cylindrical bore. The range of shaft diameters is between 470 mm and 1320 mm.

Bearing type and sizes

Bearing type	Size
Spherical roller bearings	249/470...-K30 to 249/1250...-K30
■ with tapered bore and adjustment sleeve	
■ with cylindrical bore	249/500 to 249/1320

Split spherical roller bearings

On the locating bearing side of the converter, an unsplit spherical roller bearing can be replaced by a split spherical roller bearing. Since there is no need to dismount the drive system, the work involved in mounting can be considerably reduced.

Further information

- TPI 148, Rolling Bearing Arrangements for Converters.

Split plummer block housings KPG, KPGZ

Housing materials and anti-corrosion protection

The standard material for the housing bodies is spheroidal graphite cast iron (suffix D). Housings made from other materials are available by agreement.

All outer surfaces not machined by chip-forming methods have a universal paint coating (colour RAL 7031, bluish-grey). The coating can be finished using all synthetic resin, polyurethane, acrylic, epoxy resin, chlorinated rubber, nitrocellulose and acid-hardening hammer tone finishes.

Inner and outer surfaces machined by chip-forming methods are provided with anti-corrosion protection.

Locating and non-locating bearings

The housings are supplied as a locating bearing design or non-locating bearing design. The locating bearing on the drive side provides axial guidance of the converter support ring.

The locating bearing design of the housings KPG and KPGZ is originally designed for the fitting of unsplit spherical roller bearings. The locating bearing is formed by fitting locating rings on both sides of the bearing, *Figure 2* and *Figure 3*, page 233.

A housing of the locating bearing design can also accommodate a split spherical roller bearing, replacing an unsplit bearing, *Figure 4* and *Figure 5*, page 234. As a result, the bearing can be replaced without dismounting the drive system.

The non-locating bearing design is fitted with unsplit bearings. The bearing outer ring can be displaced axially in a bearing sleeve.

Seals

Plummer block housings KPG and KPGZ are sealed by means of high-pressure packing. This allows shaft misalignment of up to 1,5°. Profiled rubber seals are available by agreement as special seals, *Figure 1*.

- ① High-pressure packing
- ② Profiled rubber seal

Figure 1
Seals for plummer block housings KPG and KPGZ

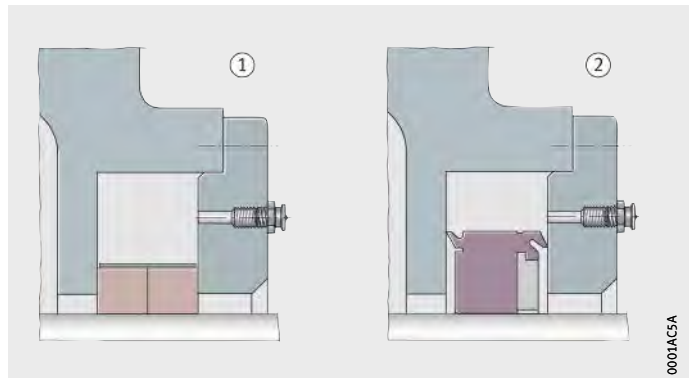

Housing configurations

Plummer block housings KPG are used for bearings with a tapered bore and adjustment sleeve, while plummer block housings KPGZ are used for bearings with a cylindrical bore, *Figure 2* and *Figure 3*.

In the case of plummer block housings KPG and KPGZ, the following features can be varied in the housing configuration:

- sealing of the housing by means of high-pressure packing or a profiled rubber seal
- design of the bearing arrangement as a locating bearing arrangement or a non-locating bearing arrangement
- spherical roller bearing in a split or unsplit design.



- ① Locating bearing KPG...F
- ② Non-locating bearing KPG...L

Figure 2
Plummer block housings KPG
for bearings with tapered bore and
adjustment sleeve

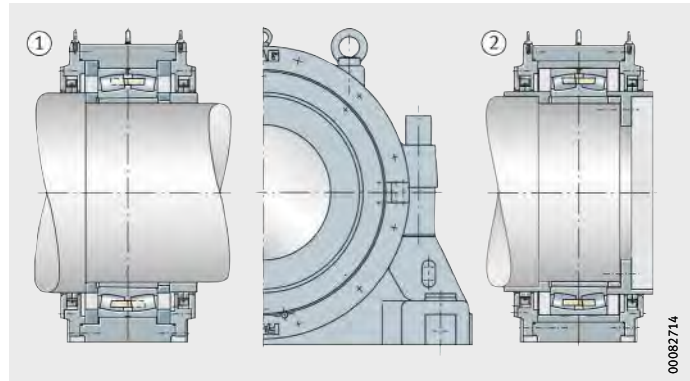

- ① Locating bearing KPGZ...F
- ② Non-locating bearing KPGZ...L

Figure 3
Plummer block housings KPGZ
for bearings with cylindrical bore

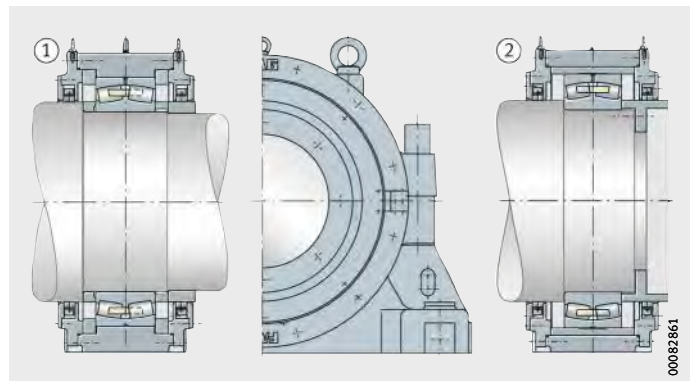

Split plummer block housings KPG, KPGZ

Mounting of split spherical roller bearings

In the case of plummer block housings KPG and KPGZ, an unsplit spherical roller bearing can be replaced, but only as standard in the locating bearing design F, *Figure 4* and *Figure 5*.

Housings of the non-locating bearing design L, which allow the use of split spherical roller bearings, are available by agreement as a special solution. Please ask for further information.

① Locating bearing KPG...F with split bearing

Figure 4
Plummer block housing KPG for bearings with tapered bore and adjustment sleeve, with split bearing

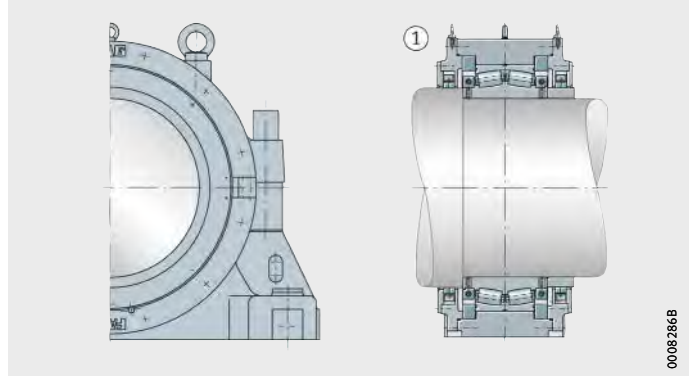

00082868

① Locating bearing KPGZ...F with split bearing

Figure 5
Plummer block housing KPGZ for bearings with cylindrical bore, with split bearing

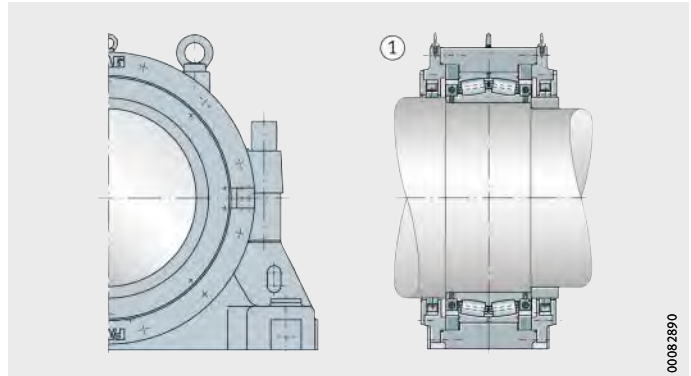

00082890

Lubrication Split plummer block housings KPG and KPGZ are designed for grease lubrication.

Greases Lithium soap greases with highly effective EP and anti-corrosion protection additives are suitable. We recommend the use of Arcanol LOAD400.

Grease quantities In initial greasing, the bearing is filled with grease to 100% and the housing cavities are filled to 60%. The recommended grease quantity is dependent not only on the housing size but also on its design, see dimension tables.

Relubrication Relubrication should be carried out using the same grease as for the initial lubrication. The bearings, displacement sleeve and seals are relubricated in accordance with an audit plan.

Designation structure The designation structure for split plummer block housings KPG and KPGZ is shown in the table and *Figure 6*.



Designation structure of plummer block housings KPG and KPGZ

Feature	Code	Description
① Series	KPG	Split plummer block housings KPG
	KPGZ	Split plummer block housings KPGZ
② ISO dimension series of bearing	49	ISO dimension series 49
③ Bore code of bearing	/850	Bore diameter 850 mm
④ Housing design	F	Locating bearing
	L	Non-locating bearing
⑤ Housing material	D	Spheroidal graphite cast iron (standard)

Figure 6
Designation structure of plummer block housings KPG and KPGZ, example



Split plummer block housings KPG, KPGZ

Ordering examples

When ordering split plummer block housings KPG and KPGZ, the designation contains indications of the size of the bearing as well as the design and material of the housing. The rolling bearing and, if necessary, the sleeve must be ordered separately.

The ordering examples show the construction of orders for selected housing combinations and the appropriate bearings. The allocation of housings, bearings and sleeves for all housing sizes is shown in the dimension tables.

Customer-specific solutions are developed for each converter application on the basis of split plummer block housings KPG and KPGZ. The housings can be supplemented by the use of additional components and modified where necessary. Before placing any orders for these housings, we therefore recommend contacting our engineering service.

Example 1 Plummer block housing KGP made from spheroidal graphite cast iron, spherical roller bearing with pin cage Z-541834.249/1060-B-K30 as locating bearing, sleeve.

Order	1 plummer block housing	KPG49/1000-F-D
	1 spherical roller bearing	Z-541834.249/1060-B-K30
	1 sleeve	Z-525000.KH

Example 2 Plummer block housing KGPZ made from spheroidal graphite cast iron, split spherical roller bearing Z-533567.PRL as locating bearing.

Order	1 plummer block housing	KPGZ49/1000-F-D
	1 split spherical roller bearing	Z-533567.PRL

Design and safety guidelines

Eye bolts

The upper housing section has 2 eye bolts in accordance with DIN 580. These are intended as locating points for mounting and dismounting of the housing. The load carrying capacity of the eye bolts only allows lifting of the housing without a bearing.

A further eye bolt is located in each of the two covers on the housing.



The eye bolts must always be screwed in fully.

The eye bolts in the upper housing section must not be subjected to a load that is more than the mass of the housing.

The eye bolt in the cover must not be subjected to a load that is more than the mass of the cover.

Foot screws

Foot screws are used for screw mounting of the housing to the locating surface. They are not included in the scope of delivery of the housings.

The appropriate screw size for each housing is stated, see dimension tables.

The associated tightening torques are stated for screws with a metric thread in accordance with DIN 13, DIN 962 and DIN ISO 965-2, see table, page 42.

Accuracy

The bearing seat in split plummer block housings KPG and KPGZ is machined to the tolerance class H7.

By agreement, the housings can also be supplied with other tolerance classes for the bearing seat, see section Tolerance class of bearing seat, page 47.



Plummer block housings

KPG, split
For spherical roller bearings with tapered bore and sleeve, for split spherical roller bearings

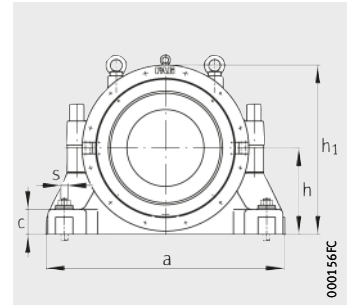
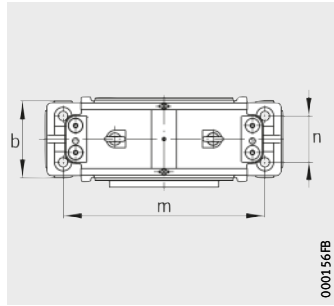

Dimension table - Dimensions in mm

Shaft		Housing Dimensions											
d ₁	d ₂	h	h ₁	g ₁	b	c	a	m	n	s	D	w	k
470	540	425	820	400	375	130	1 170	975	230	M42	670	125	40
500	570	450	875	410	400	140	1 240	1 050	240	M42	710	130	40
530	600	475	930	420	420	145	1 320	1 100	255	M48	750	135	40
570	645	500	980	460	440	155	1 400	1 150	270	M52	800	145	40
600	675	535	1 040	480	480	165	1 500	1 225	295	M56	850	155	40
630	720	570	1 110	500	500	175	1 570	1 300	310	M56	900	165	40
670	760	600	1 170	560	535	185	1 660	1 375	325	M64	950	175	50
710	800	630	1 240	590	550	195	1 750	1 450	335	M64	1 000	180	50
750	860	670	1 310	600	570	205	1 850	1 550	345	M72	1 060	185	50
800	910	710	1 390	630	600	220	1 960	1 600	360	M72	1 120	195	50
850	960	740	1 450	660	620	230	2 060	1 700	370	M80	1 180	200	60
900	1 015	800	1 550	680	660	250	2 200	1 820	390	M90	1 250	210	60
950	1 065	830	1 620	720	650	255	2 330	1 980	360	M90	1 320	230	70
1 000	1 135	880	1 710	780	740	275	2 450	2 000	460	M100	1 400	245	60
1 060	1 195	920	1 780	800	740	285	2 560	2 150	460	M100	1 460	245	70
1 120	1 260	970	1 880	820	780	300	2 700	2 300	480	M110	1 540	260	70
1 180	1 330	1 010	1 985	850	820	320	2 850	2 400	510	M110	1 630	275	70
1 250	1 400	1 080	2 100	900	850	340	3 000	2 500	520	M125	1 720	290	70

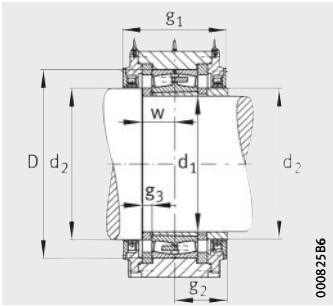

KPG49..-F (unsplit bearing)
Locating bearing

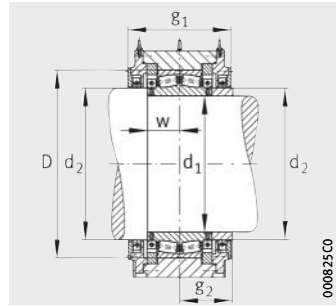

KPG49..-F (split bearing)
Locating bearing

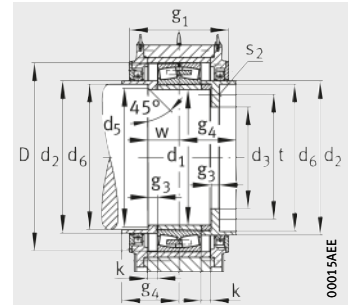

KPG49..-L (unsplit bearing)
Non-locating bearing



g ₂	g ₃	g ₄	d ₃	d ₅	d ₆	t	s ₂		Housing Designation
							DIN 931	Quantity	
210	40	230	375	480	505	437,5	M20×70	8	KPG49/470..-D
215	40	235	400	510	535	465	M20×70	8	KPG49/500..-D
220	40	240	420	540	565	490	M20×70	8	KPG49/530..-D
240	45	260	450	580	610	525	M20×80	8	KPG49/570..-D
250	46	270	475	612	640	552,5	M20×80	8	KPG49/600..-D
260	50	280	505	642	675	587,5	M24×90	8	KPG49/630..-D
290	53,5	317,5	535	682	715	622,5	M24×90	8	KPG49/670..-D
305	55	332,5	565	722	755	657,5	M30×100	8	KPG49/710..-D
310	56	337,5	600	762	805	700	M30×100	8	KPG49/750..-D
325	59	352,5	640	812	855	745	M30×110	8	KPG49/800..-D
340	60	375	675	862	905	787,5	M30×110	8	KPG49/850..-D
350	60	385	715	915	960	832,5	M36×110	8	KPG49/900..-D
370	72,5	412,5	750	965	1010	875	M36×130	8	KPG49/950..-D
400	77,5	435	795	1015	1070	927,5	M36×130	8	KPG49/1000..-D
410	77,5	452,5	840	1075	1130	980	M42×140	8	KPG49/1060..-D
420	82,5	462,5	885	1135	1190	1032,5	M42×140	8	KPG49/1120..-D
435	87,5	477,5	940	1195	1255	1095	M42×150	8	KPG49/1180..-D
460	90	502,5	990	1265	1325	1155	M48×180	8	KPG49/1250..-D

Plummer block housings

KPG, split
For spherical roller bearings with tapered bore and sleeve, for split spherical roller bearings

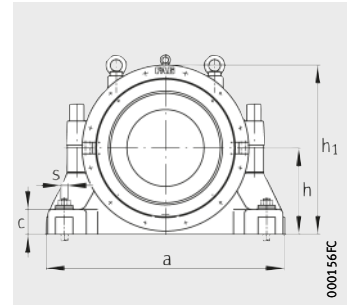
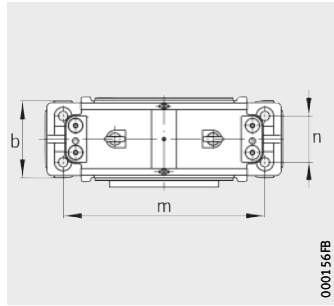

Dimension table (continued) · Dimensions in mm

Shaft		Bearing		Sleeve	Split bearing (for locating bearings only)
d ₁	d ₂	MB cage	Pin cage		
470	540	Z-528741.PRL-K30	Z-541821.249/500-K30	Z-524974.KH	Z-529173.PRL
500	570	Z-528742.PRL-K30	Z-541822.249/530-K30	Z-524976.KH	Z-528441.PRL
530	600	Z-528743.PRL-K30	Z-541823.249/560-B-K30	Z-524978.KH	Z-529223.PRL
570	645	Z-528744.PRL-K30	Z-541824.249/600-B-K30	Z-524980.KH	Z-529224.PRL
600	675	–	Z-541825.249/630-K30	Z-524982.KH	Z-529225.PRL
630	720	Z-528746.PRL-K30	Z-541826.249/670-K30	Z-524984.KH	Z-529226.PRL
670	760	Z-528747.PRL-K30	Z-541827.249/710-B-K30	Z-524986.KH	Z-529227.PRL
710	800	Z-528748.PRL-K30	Z-541828.249/750-B-K30	Z-524988.KH	Z-527943.PRL
750	860	Z-528749.PRL-K30	Z-541829.249/800-B-K30	Z-524990.KH	Z-529228.PRL
800	910	Z-528750.PRL-K30	Z-541830.249/850-B-K30	Z-524992.KH	Z-529229.PRL
850	960	Z-528751.PRL-K30	Z-541831.249/900-B-K30	Z-524994.KH	Z-529230.PRL
900	1015	Z-528752.PRL-K30	Z-541832.249/950-B-K30	Z-524996.KH	Z-527254.PRL
950	1065	Z-528753.PRL-K30	Z-541833.249/1000-B-K30	Z-524998.KH	Z-529231.PRL
1000	1135	–	Z-541834.249/1060-B-K30	Z-525000.KH	Z-529232.PRL
1060	1195	–	Z-541835.249/1120-B-K30	Z-525001.KH	Z-529233.01.PRL
1120	1260	–	Z-541836.249/1180-B-K30	Z-525003.KH	Z-529234.PRL
1180	1330	–	Z-541837.249/1250-B-K30	Z-525005.KH	–
1250	1400	–	Z-541838.249/1320-B-K30	Z-525007.KH	Z-529215.PRL

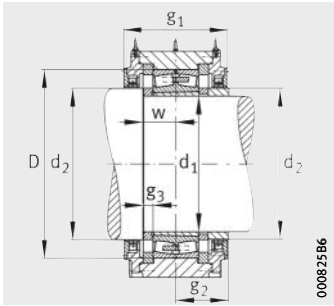

KPG49..-F (unsplit bearing)
Locating bearing

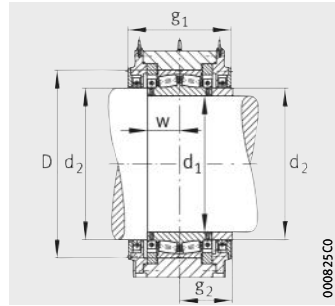

KPG49..-F (split bearing)
Locating bearing

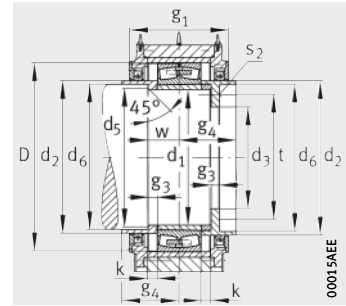

KPG49..-L (unsplit bearing)
Non-locating bearing



Housing

Initial grease filling quantity			Mass m ≈ kg	Designation
Locating bearing		Non-locating bearing		
Unsplit ≈ kg	Split ≈ kg	Unsplit ≈ kg		
10	8	14	945	KPG49/470..-D
10	8	14	1 050	KPG49/500..-D
13	10	15	1 365	KPG49/530..-D
15	12	20	1 575	KPG49/570..-D
20	15	24	2 205	KPG49/600..-D
22	18	25	2 625	KPG49/630..-D
26	20	30	2 835	KPG49/670..-D
30	24	35	2 940	KPG49/710..-D
35	26	40	3 465	KPG49/750..-D
40	30	50	3 885	KPG49/800..-D
45	35	55	4 515	KPG49/850..-D
55	45	65	5 460	KPG49/900..-D
65	50	80	5 660	KPG49/950..-D
75	60	95	7 140	KPG49/1000...-D
80	65	100	8 400	KPG49/1060...-D
95	75	110	9 450	KPG49/1120...-D
110	–	130	11 550	KPG49/1180...-D
125	100	170	13 440	KPG49/1250...-D

Plummer block housings

KPGZ, split

For spherical roller bearings with cylindrical bore, for split spherical roller bearings

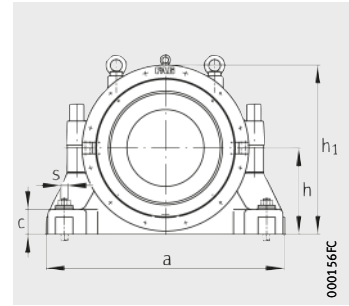
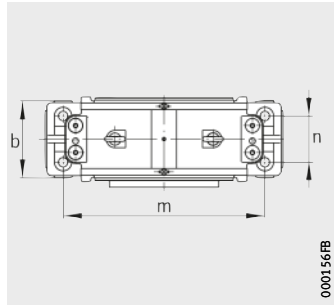

Dimension table - Dimensions in mm

Shaft			Housing Dimensions											
d	d ₂	d ₄	h	h ₁	g ₁	b	c	a	m	n	s	D	w	w _L
500	540	495	425	820	400	375	130	1 170	975	230	M42	670	125	85
530	570	525	450	875	410	400	140	1 240	1 050	240	M42	710	130	90
560	600	555	475	930	420	420	145	1 320	1 100	255	M48	750	135	95
600	645	595	500	980	460	440	155	1 400	1 150	270	M52	800	145	100
630	675	625	535	1 040	480	480	165	1 500	1 225	295	M56	850	155	109
670	720	665	570	1 110	500	500	175	1 570	1 300	310	M56	900	163	115
710	760	695	600	1 170	560	535	185	1 660	1 375	325	M64	950	175	122
750	800	745	630	1 240	590	550	195	1 750	1 450	335	M64	1 000	178	125
800	860	795	670	1 310	600	570	205	1 850	1 550	345	M72	1 060	185	129
850	910	845	710	1 390	630	600	220	1 960	1 600	360	M72	1 120	193	136
900	960	895	740	1 450	660	620	230	2 060	1 700	370	M80	1 180	195	140
950	1 015	945	800	1 550	680	660	250	2 200	1 820	390	M90	1 250	205	150
1 000	1 065	985	830	1 620	720	650	255	2 330	1 980	360	M90	1 320	225	158
1 060	1 135	1 055	880	1 710	780	740	275	2 450	2 000	460	M100	1 400	238	168
1 120	1 195	1 115	920	1 780	800	740	285	2 560	2 150	460	M100	1 460	238	168
1 180	1 260	1 175	970	1 880	820	780	300	2 700	2 300	480	M110	1 540	250	178
1 250	1 330	1 245	1 010	1 985	850	820	320	2 850	2 400	510	M110	1 630	273	188
1 320	1 400	1 315	1 080	2 100	900	850	340	3 000	2 500	520	M125	1 720	290	200

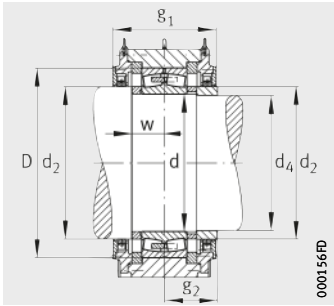

KPGZ49..-F (unsplit bearing)
Locating bearing

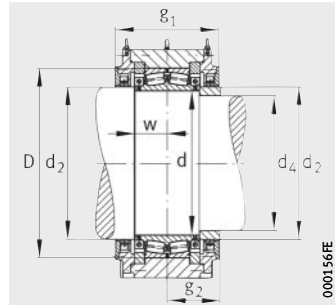

KPGZ49..-F (unsplit bearing)
Locating bearing

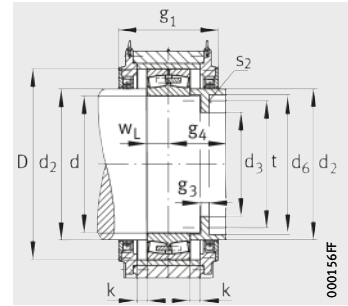

KPGZ49..-F (unsplit bearing)
Non-locating bearing



k	g ₂	g ₃	g ₄	d ₃	d ₆	t	S ₂		Housing Designation
							DIN 931	Quantity	
40	210	40	230	375	505	437,5	M20×70	8	KPGZ49/500..-D
40	215	40	235	400	535	465	M20×70	8	KPGZ49/530..-D
40	220	40	240	420	565	490	M20×70	8	KPGZ49/560..-D
40	240	45	260	450	610	525	M20×80	8	KPGZ49/600..-D
40	250	46	270	475	640	552,5	M20×80	8	KPGZ49/630..-D
40	260	48	280	505	675	587,5	M24×90	8	KPGZ49/670..-D
50	290	54	318	535	715	622,5	M24×90	8	KPGZ49/710..-D
50	305	53	333	565	755	657,5	M30×100	8	KPGZ49/750..-D
50	310	56	338	600	805	700	M30×100	8	KPGZ49/800..-D
50	325	57	353	640	855	745	M30×110	8	KPGZ49/850..-D
60	340	55	375	675	905	787,5	M30×110	8	KPGZ49/900..-D
60	350	55	385	715	960	832,5	M36×110	8	KPGZ49/950..-D
70	370	68	413	750	1010	875	M36×130	8	KPGZ49/1000..-D
60	400	70	435	795	1070	927,5	M36×130	8	KPGZ49/1060..-D
70	410	70	453	840	1130	980	M42×140	8	KPGZ49/1120..-D
70	420	73	463	885	1190	1032,5	M42×140	8	KPGZ49/1180..-D
70	435	85	478	940	1255	1095	M42×150	8	KPGZ49/1250..-D
70	460	90	503	990	1325	1155	M48×180	8	KPGZ49/1320..-D

Plummer block housings

KPGZ, split
 For spherical roller bearings with cylindrical bore,
 for split spherical roller bearings

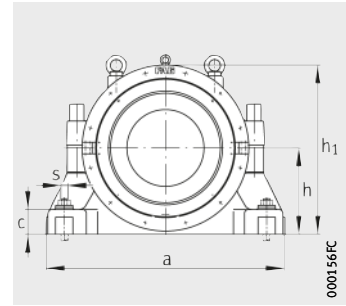
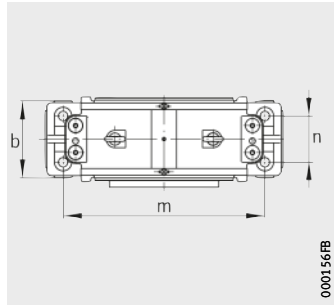

Dimension table (continued) · Dimensions in mm

Shaft			Bearing		Split bearing (for locating bearings only)
d	d ₂	d ₄	MB cage	Pin cage	
500	540	495	Z-528741.PRL	Z-541821.249/500	Z-537276.PRL
530	570	525	Z-528742.PRL	Z-541822.249/530	Z-537277.PRL
560	600	555	Z-528743.PRL	Z-541823.249/560-B	Z-537278.PRL
600	645	595	Z-528744.PRL	Z-541824.249/600-B	Z-533761.PRL
630	675	625	–	Z-541825.249/630	Z-537279.PRL
670	720	665	Z-528746.PRL	Z-541826.249/670	Z-537280.PRL
710	760	695	Z-528747.PRL	Z-541827.249/710-B	Z-526073.PRL
750	800	745	Z-528748.PRL	Z-541828.249/750-B	Z-533414.01.PRL
800	860	795	Z-528749.PRL	Z-541829.249/800-B	Z-532063.PRL
850	910	845	Z-528750.PRL	Z-541830.249/850-B	Z-537281.PRL
900	960	895	Z-528751.PRL	Z-541831.249/900-B	Z-537282.PRL
950	1015	945	Z-528752.PRL	Z-541832.249/950-B	Z-534826.PRL
1000	1065	985	Z-528753.PRL	Z-541833.249/1000-B	Z-533567.PRL
1060	1135	1055	–	Z-541834.249/1060-B	Z-537283.PRL
1120	1195	1115	–	Z-541835.249/1120-B	Z-537284.PRL
1180	1260	1175	–	Z-541836.249/1180-B	Z-536806.PRL
1250	1330	1245	–	Z-541837.249/1250-B	Z-537285.PRL
1320	1400	1315	–	Z-541838.249/1320-B	Z-545161.PRL

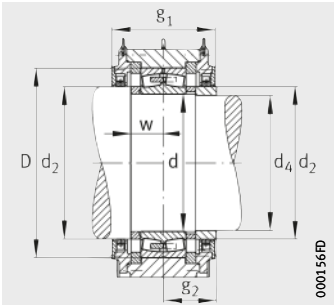

KPGZ49..-F (unsplit bearing)
Locating bearing

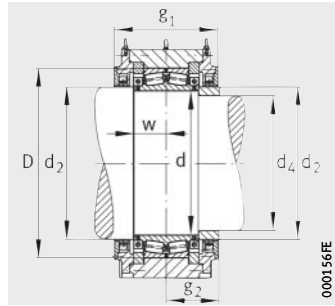

KPGZ49..-F (split bearing)
Locating bearing

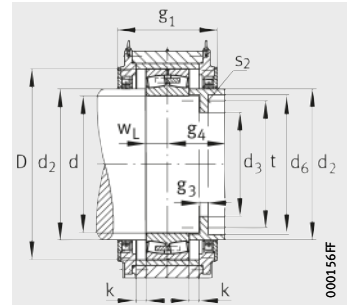

KPGZ49..-F (unsplit bearing)
Non-locating bearing



Housing

Initial grease filling quantity			Mass m ≈ kg	Designation
Locating bearing		Non-locating bearing		
Unsplit ≈ kg	Split ≈ kg	Unsplit ≈ kg		
10	8	14	900	KPGZ49/500..-D
10	8	14	1 000	KPGZ49/530..-D
13	10	15	1 300	KPGZ49/560..-D
15	12	20	1 500	KPGZ49/600..-D
20	15	24	2 100	KPGZ49/630..-D
22	18	25	2 500	KPGZ49/670..-D
26	20	30	2 700	KPGZ49/710..-D
30	24	35	2 800	KPGZ49/750..-D
35	26	40	3 300	KPGZ49/800..-D
40	30	50	3 700	KPGZ49/850..-D
45	35	55	4 300	KPGZ49/900..-D
55	45	65	5 200	KPGZ49/950..-D
65	50	80	5 770	KPGZ49/1000..-D
75	60	95	6 800	KPGZ49/1060..-D
80	65	100	8 000	KPGZ49/1120..-D
95	75	110	9 000	KPGZ49/1180..-D
110	85	130	11 000	KPGZ49/1250..-D
125	100	170	12 800	KPGZ49/1320..-D



Split plummer block housings LOE

Split plummer block housings LOE

		Page
Product overview	Split plummer block housings LOE	248
Features	Suitable bearings	249
	Housing materials and anti-corrosion protection	249
	Locating and non-locating bearings	249
	Seals and covers	250
	Housing configurations.....	250
	Lubrication	252
	Designation structure	253
	Ordering examples	254
Design and safety guidelines	Eye bolts	255
	Foot screws	255
Accuracy	255
Dimension tables	Plummer block housings LOE, split, for spherical roller bearings with tapered bore and adapter sleeve.....	256
	Plummer block housings LOE, split, for spherical roller bearings with cylindrical bore.....	260



Product overview Split plummer block housings LOE

Plummer block housings

Split

Closed on one side, with cover

LOE..-AF, LOE..-AL



0001ACE0

For continuous shaft

LOE..-BF, LOE..-BL



0001ACE1

Split plummer block housings LOE

Features Split plummer block housings LOE are designed for oil lubrication. They are suitable for high speed bearing arrangements, for example in fans.



Suitable bearings The dimensions of split plummer block housings LOE are matched to spherical roller bearings 222 and 223, see table. The housings LOE2 and LOE3 are intended for bearings with a cylindrical bore, while the housings LOE5 and LOE6 are intended for bearings with a tapered bore and adapter sleeve. The range of shaft diameters is between 50 mm and 240 mm.



Bearing type and sizes

Bearing type	Size
Spherical roller bearings	22217..-K to 22248..-K
■ with tapered bore and adapter sleeve	22314..-K to 22336..-K
■ with cylindrical bore	22214 to 22248
	22310 to 22336



Housing materials and anti-corrosion protection

The standard material for the housing bodies is flake graphite cast iron (suffix L). By agreement, housing bodies made from spheroidal graphite cast iron (suffix D) or cast steel (suffix S) are available.

All outer surfaces not machined by chip-forming methods have a universal paint coating (colour RAL 7031, bluish-grey). The coating can be finished using all synthetic resin, polyurethane, acrylic, epoxy resin, chlorinated rubber, nitrocellulose and acid-hardening hammer tone finishes.

Inner and outer surfaces machined by chip-forming methods are provided with anti-corrosion protection that can be easily removed. It is recommended that only volatile solvents and lint-free cloths should be used.

Locating and non-locating bearings

The housings are supplied as a locating bearing design or non-locating bearing design. In the locating bearing, the bearing is clamped between the housing covers. In the non-locating bearing, the bearing can align itself axially, since the covers have shorter centring collars.

Split plummer block housings LOE

Seals and covers

Plummer block housings LOE of design A are intended for the bearing arrangements of shaft ends. One side is closed by a cover and the other side is sealed against the shaft. Design B is intended for continuous shafts, in which case the housing is sealed against the shaft on both sides.

A labyrinth seal is used in this case, *Figure 1*. The labyrinth rings are unsplit. The grease chamber in the labyrinth can be relubricated.

The labyrinth seal allows shaft misalignment of up to 0,25° in both directions and is suitable for oil lubrication.

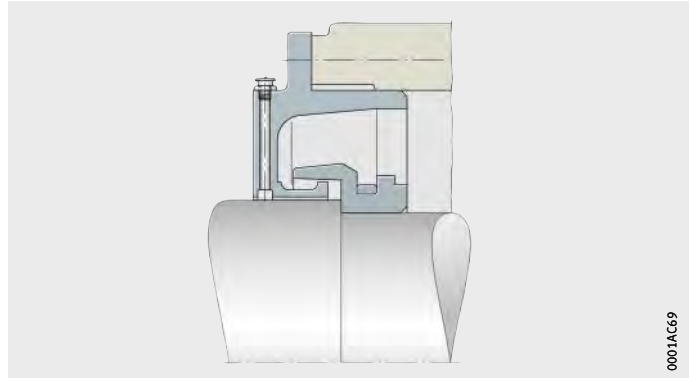

Figure 1
Labyrinth seal
for plummer block housing LOE

Housing configurations

In the case of plummer block housings LOE, various housing configurations are possible that are clearly described by means of the designation, *Figure 2* to *Figure 5*, page 251.

The following features can be varied in the housing configuration:

- location of bearings with a tapered bore by means of an adapter sleeve on a shaft of constant diameter or of bearings with a cylindrical bore directly on a stepped shaft
- continuous shaft or a housing closed on one side
- design of the bearing arrangement as a locating bearing arrangement or a non-locating bearing arrangement
- design with or without cooling coil, *Figure 6*, page 252.

- ① Locating bearing LOE...N-AF
- ② Non-locating bearing LOE...N-AL

Figure 2
Plummer block housings
LOE5, LOE6 for bearings
with tapered bore
and adapter sleeve,
design A

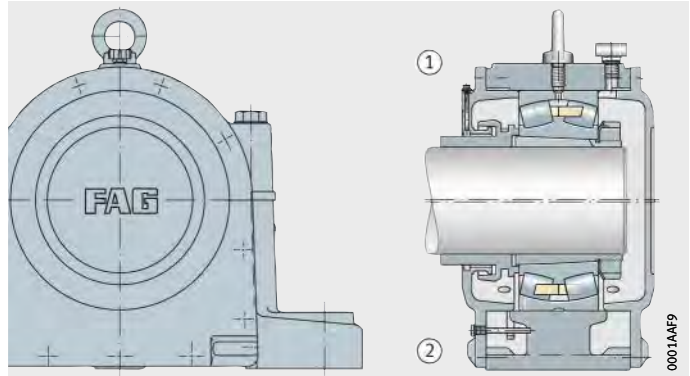

- ① Locating bearing LOE...N-BF
- ② Non-locating bearing LOE...N-BL

Figure 3
Plummer block housings
LOE5, LOE6 for bearings
with tapered bore
and adapter sleeve,
design B

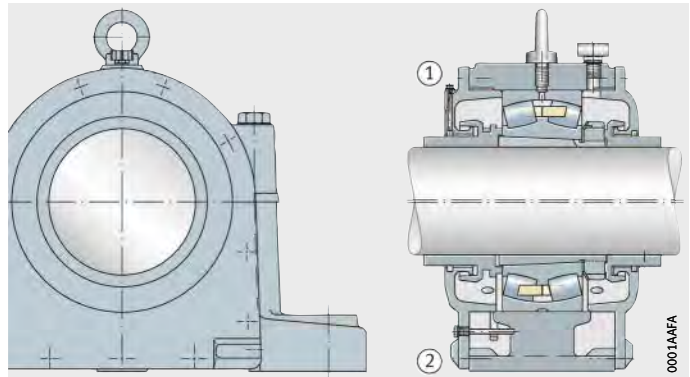

- ① Locating bearing LOE...N-AF
- ② Non-locating bearing LOE...N-AL

Figure 4
Plummer block housings
LOE2, LOE3 for bearings
with cylindrical bore,
design A

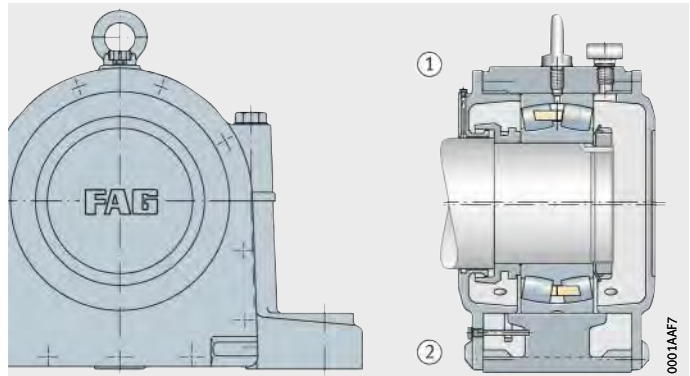

- ① Locating bearing LOE...N-BF
- ② Non-locating bearing LOE...N-BL

Figure 5
Plummer block housings
LOE2, LOE3 for bearings
with cylindrical bore,
design B

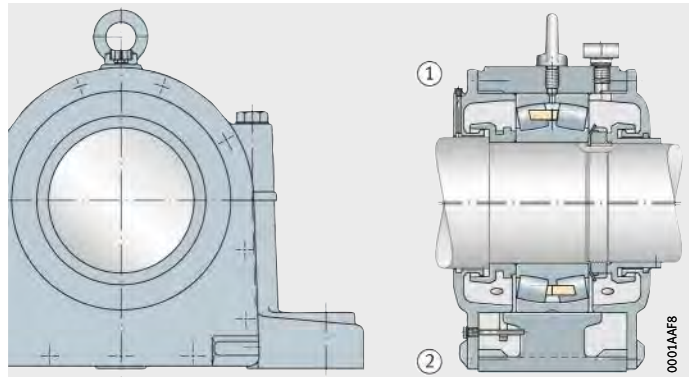

Split plummer block housings LOE

Lubrication

Split plummer block housings LOE are designed for oil lubrication. They are suitable for high speed bearing arrangements. The oil gives good heat dissipation from the bearing.

Oil bath lubrication

Oil lubrication is used as the lubrication method for the housings. The oil is supplied to the rolling bearing from the oil sump in the lower housing section by a ring oiler. An angled oil level indicator is screwed to one cover.

If cooling of the oil is necessary, the housings can be ordered in a design with a cooling coil (suffix E), *Figure 6*. The cooling coil is located in the area of the oil sump in the lower housing section and can be connected to an external cooling circuit.

- ① Angled oil level indicator
- ② Ring oiler
- ③ Cooling coil
- ④ Connectors for external cooling circuit

Figure 6
Plummer block housing LOE..-E
with cooling coil

Recirculating oil lubrication

By agreement, a housing design for recirculating oil lubrication can be ordered using the designation F-582158.LOU. Please ask for further information.

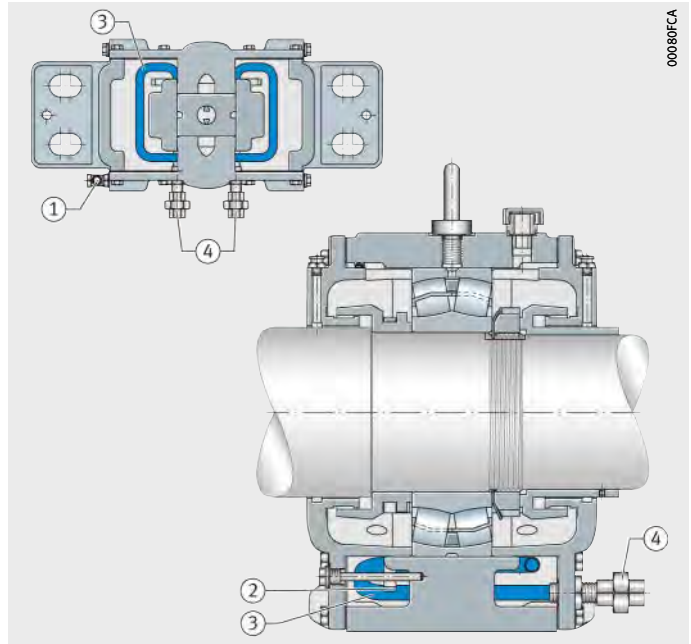

Designation structure

The designation structure for split plummer block housings LOE is shown in the table and *Figure 7*.

Designation structure of plummer block housings LOE

Feature	Code	Description
① Series	LOE	Split plummer block housings LOE
② Diameter series of bearing, bearing bore	2	Bearings of diameter series 2, cylindrical bearing bore
	3	Bearings of diameter series 3, cylindrical bearing bore
	5	Bearings of diameter series 2, tapered bearing bore and adapter sleeve
	6	Bearings of diameter series 3, tapered bearing bore and adapter sleeve
③ Bore code of bearing	38	Bore diameter (38 · 5) mm = 190 mm
④ Oil lubrication	N	Standard design
	E	Design with cooling coil
⑤ Housing design	AF	Closed on one side, locating bearing
	AL	Closed on one side, non-locating bearing
	BF	Continuous shaft, locating bearing
	BL	Continuous shaft, non-locating bearing
⑥ Housing material	L	Flake graphite cast iron (standard)
	D	Spheroidal graphite cast iron
	S	Cast steel



Figure 7
Designation structure of plummer block housings LOE, example

Split plummer block housings LOE

Ordering examples

When ordering a split plummer block housing LOE, the designation contains indications of the size and location method of the bearing, the type of oil cooling and the design and material of the housing. The rolling bearing and, if necessary, the adapter sleeve or locknut must be ordered separately.

The ordering examples show the construction of orders for selected housing combinations and the appropriate bearings. The allocation of housings, bearings and accessories for all housing sizes is shown in the dimension tables.

Example 1 Plummer block housing LOE made from flake graphite cast iron, for continuous shaft, spherical roller bearing 22238-K-MB as locating bearing, location using adapter sleeve. Housing for oil cooling of standard design.

Order 1 plummer block housing LOE538-N-BF-L
1 spherical roller bearing 22238-K-MB
1 adapter sleeve H3138-HG

Example 2 Plummer block housing LOE made from flake graphite cast iron, for continuous shaft, spherical roller bearing 22238-MB as locating bearing, location using locknut. Housing for oil cooling of standard design.

Order 1 plummer block housing LOE238-N-BF-L
1 spherical roller bearing 22238-MB
1 locknut KM38
1 tab washer MB38

Design and safety guidelines

Eye bolts

The upper housing section has an eye bolt in accordance with DIN 580. This is intended as a locating point for mounting and dismantling of the housing. The load carrying capacity of the eye bolt allows lifting of the housing including a bearing fitted in the housing.



The eye bolt must always be screwed fully into the housing. The eye bolt must not be subjected to a mass greater than that of the housing together with the bearing fitted in the housing.

Foot screws

Foot screws are used for screw mounting of the housing to the locating surface. They are not included in the scope of delivery of the housings.

The appropriate screw size for each housing is stated, see dimension tables.

The associated tightening torques are stated for screws with a metric thread in accordance with DIN 13, DIN 962 and DIN ISO 965-2, see table, page 42.

Accuracy

The bearing seat in split plummer block housings LOE is machined to the tolerance class G6.

By agreement, the housings can also be supplied with other tolerance classes for the bearing seat, see section Tolerance class of bearing seat, page 47.



Plummer block housings

LOE, split
For spherical roller bearings with tapered bore and adapter sleeve

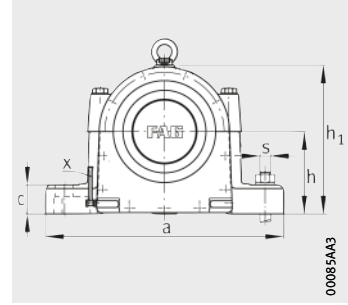
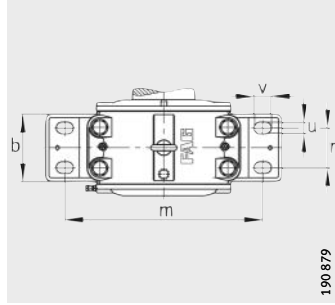

Dimension table - Dimensions in mm

Shaft d_1	Housing Dimensions													
	h	h_1	g	g_1	b	c	a	m	n	v	u	s	D	g_3
60	135	240	160	225	150	48	410	340	80	35	25	M20	150	18
60	135	240	160	225	150	48	410	340	80	35	25	M20	150	-
70	150	270	170	250	160	50	490	400	80	45	30	M24	170	18
70	150	270	170	250	160	50	490	400	80	45	30	M24	170	-
75	135	240	160	225	150	48	410	340	80	35	25	M20	150	18
75	135	240	160	225	150	48	410	340	80	35	25	M20	150	-
80	135	245	160	225	150	48	410	340	80	35	25	M20	160	17,5
80	135	245	160	225	150	48	410	340	80	35	25	M20	160	-
80	175	305	175	250	165	55	500	420	80	45	30	M24	190	18
80	175	305	175	250	165	55	500	420	80	45	30	M24	190	-
85	150	270	170	250	160	50	490	400	80	45	30	M24	170	18
85	150	270	170	250	160	50	490	400	80	45	30	M24	170	-
90	150	270	170	250	160	50	490	400	80	45	30	M24	180	20
90	150	270	170	250	160	50	490	400	80	45	30	M24	180	-
90	175	320	175	250	165	55	550	440	80	50	36	M30	215	18
90	175	320	175	250	165	55	550	440	80	50	36	M30	215	-
100	165	300	175	250	165	50	510	420	80	45	30	M24	200	18
100	165	300	175	250	165	50	510	420	80	45	30	M24	200	-
100	180	335	190	270	180	65	570	460	95	50	36	M30	240	20
100	180	335	190	270	180	65	570	460	95	50	36	M30	240	-
110	175	320	175	250	165	55	550	440	80	50	36	M30	215	18
110	175	320	175	250	165	55	550	440	80	50	36	M30	215	-
110	220	390	210	300	200	75	660	530	110	60	42	M36	260	18
110	220	390	210	300	200	75	660	530	110	60	42	M36	260	-
115	190	345	185	260	175	65	570	460	90	50	36	M30	230	18
115	190	345	185	260	175	65	570	460	90	50	36	M30	230	-
115	235	420	220	315	200	80	660	530	110	60	42	M36	280	18
115	235	420	220	315	200	80	660	530	110	60	42	M36	280	-

① Locating bearing AF; ② Non-locating bearing AL; ③ Locating bearing BF; ④ Non-locating bearing BL

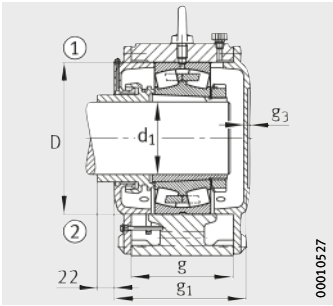

Design A

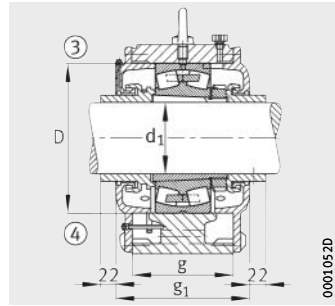

Design B



Spherical roller bearing and accessories		Oil quantity	Oil level	Housing		
Bearing	Adapter sleeve			Initial filling l	Height x mm	Mass m ≈ kg
		Locating bearing	Non-locating bearing			
22314..-K	H2314	1,4	50 – 65	45	LOE614-N-AF-L	LOE614-N-AL-L
22314..-K	H2314	1,4	50 – 65	45	LOE614-N-BF-L	LOE614-N-BL-L
22316..-K	H2316	1,6	55 – 70	60	LOE616-N-AF-L	LOE616-N-AL-L
22316..-K	H2316	1,6	55 – 70	60	LOE616-N-BF-L	LOE616-N-BL-L
22217..-K	H317	1,4	50 – 65	45	LOE517-N-AF-L	LOE517-N-AL-L
22217..-K	H317	1,4	50 – 65	45	LOE517-N-BF-L	LOE517-N-BL-L
22218..-K	H318	1,5	45 – 60	47	LOE518-N-AF-L	LOE518-N-AL-L
22218..-K	H318	1,5	45 – 60	47	LOE518-N-BF-L	LOE518-N-BL-L
22318..-K	H2318	2,3	65 – 85	73	LOE618-N-AF-L	LOE618-N-AL-L
22318..-K	H2318	2,3	65 – 85	73	LOE618-N-BF-L	LOE618-N-BL-L
22219..-K	H319	1,6	55 – 70	60	LOE519-N-AF-L	LOE519-N-AL-L
22219..-K	H319	1,6	55 – 70	60	LOE519-N-BF-L	LOE519-N-BL-L
22220..-K	H320	1,7	50 – 65	67	LOE520-N-AF-L	LOE520-N-AL-L
22220..-K	H320	1,7	50 – 65	67	LOE520-N-BF-L	LOE520-N-BL-L
22320..-K	H2320	2,4	55 – 75	81	LOE620-N-AF-L	LOE620-N-AL-L
22320..-K	H2320	2,4	55 – 75	81	LOE620-N-BF-L	LOE620-N-BL-L
22222..-K	H322	2,1	50 – 70	74	LOE522-N-AF-L	LOE522-N-AL-L
22222..-K	H322	2,1	50 – 70	74	LOE522-N-BF-L	LOE522-N-BL-L
22322..-K	H2322	2,4	45 – 65	100	LOE622-N-AF-L	LOE622-N-AL-L
22322..-K	H2322	2,4	45 – 65	100	LOE622-N-BF-L	LOE622-N-BL-L
22224..-K	H3124	2,3	50 – 70	80	LOE524-N-AF-L	LOE524-N-AL-L
22224..-K	H3124	2,3	50 – 70	80	LOE524-N-BF-L	LOE524-N-BL-L
22324..-K	H2324	4,2	65 – 90	130	LOE624-N-AF-L	LOE624-N-AL-L
22324..-K	H2324	4,2	65 – 90	130	LOE624-N-BF-L	LOE624-N-BL-L
22226..-K	H3126	2,3	55 – 75	93	LOE526-N-AF-L	LOE526-N-AL-L
22226..-K	H3126	2,3	55 – 75	93	LOE526-N-BF-L	LOE526-N-BL-L
22326..-K	H2326	3,7	75 – 105	142	LOE626-N-AF-L	LOE626-N-AL-L
22326..-K	H2326	3,7	75 – 105	142	LOE626-N-BF-L	LOE626-N-BL-L

Plummer block housings

LOE, split
For spherical roller bearings with tapered bore and adapter sleeve

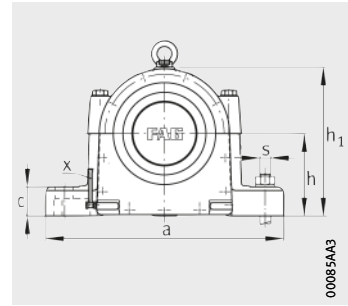
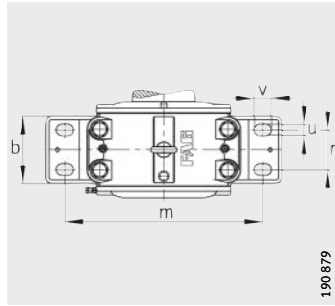

Dimension table (continued) · Dimensions in mm

Shaft d_1	Housing Dimensions													
	h	h_1	g	g_1	b	c	a	m	n	v	u	s	D	g_3
125	190	355	180	260	175	65	570	460	100	50	36	M30	250	18
125	190	355	180	260	175	65	570	460	100	50	36	M30	250	-
125	260	450	230	325	220	85	710	580	125	60	42	M36	300	19,5
125	260	450	230	325	220	85	710	580	125	60	42	M36	300	-
135	220	395	200	275	190	70	660	530	100	60	42	M36	270	18
135	220	395	200	275	190	70	660	530	100	60	42	M36	270	-
135	265	465	240	335	200	85	760	630	125	60	42	M36	320	18
135	265	465	240	335	200	85	760	630	125	60	42	M36	320	-
140	220	400	210	290	200	70	660	530	110	60	42	M36	290	20
140	220	400	210	290	200	70	660	530	110	60	42	M36	290	-
140	270	485	250	350	240	90	820	670	130	70	48	M42	340	20
140	270	485	250	350	240	90	820	670	130	70	48	M42	340	-
150	260	460	210	300	200	85	710	580	110	60	42	M36	310	18
150	260	460	210	300	200	85	710	580	110	60	42	M36	310	-
150	280	510	255	350	240	90	830	670	130	70	48	M42	360	18
150	280	510	255	350	240	90	830	670	130	70	48	M42	360	-
160	260	465	210	300	200	85	710	580	110	60	42	M36	320	20
160	260	465	210	300	200	85	710	580	110	60	42	M36	320	-
160	290	530	260	360	240	90	840	680	130	70	48	M42	380	20
160	290	530	260	360	240	90	840	680	130	70	48	M42	380	-
170	270	485	250	350	240	90	820	670	130	70	48	M42	340	20
170	270	485	250	350	240	90	820	670	130	70	48	M42	340	-
180	280	510	260	344	240	90	830	670	130	70	48	M42	360	20
180	280	510	260	344	240	90	830	670	130	70	48	M42	360	-
200	310	565	280	380	240	105	880	720	130	70	48	M42	400	20
200	310	565	280	380	240	105	880	720	130	70	48	M42	400	-
220	340	625	300	400	280	120	980	820	165	70	48	M42	440	20
220	340	625	300	400	280	120	980	820	165	70	48	M42	440	-

① Locating bearing AF; ② Non-locating bearing AL; ③ Locating bearing BF; ④ Non-locating bearing BL

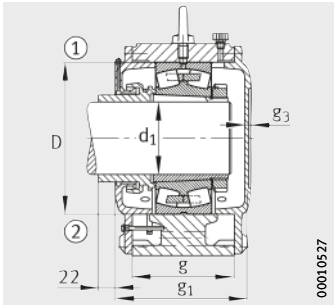

Design A

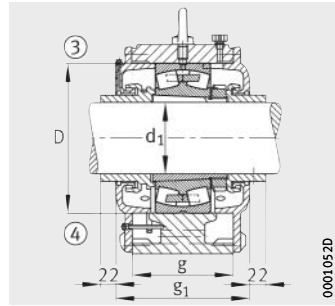

Design B



Spherical roller bearing and accessories		Oil quantity	Oil level	Housing		
Bearing	Adapter sleeve			Initial filling l	Height x mm	Mass m ≈ kg
		Locating bearing	Non-locating bearing			
22228..-K	H3128	3,7	55 – 75	100	LOE528-N-AF-L	LOE528-N-AL-L
22228..-K	H3128	3,7	55 – 75	100	LOE528-N-BF-L	LOE528-N-BL-L
22328..-K	H2328	6,7	80 – 110	170	LOE628-N-AF-L	LOE628-N-AL-L
22328..-K	H2328	6,7	80 – 110	170	LOE628-N-BF-L	LOE628-N-BL-L
22230..-K	H3130	4,2	65 – 90	125	LOE530-N-AF-L	LOE530-N-AL-L
22230..-K	H3130	4,2	65 – 90	125	LOE530-N-BF-L	LOE530-N-BL-L
22330..-K	H2330	6,2	75 – 110	200	LOE630-N-AF-L	LOE630-N-AL-L
22330..-K	H2330	6,2	75 – 110	200	LOE630-N-BF-L	LOE630-N-BL-L
22232..-K	H3132(-HG)	4,7	60 – 80	135	LOE532-N-AF-L	LOE532-N-AL-L
22232..-K	H3132(-HG)	4,7	60 – 80	135	LOE532-N-BF-L	LOE532-N-BL-L
22332..-K	H2332(-HG)	7,0	80 – 105	240	LOE632-N-AF-L	LOE632-N-AL-L
22332..-K	H2332(-HG)	7,0	80 – 105	240	LOE632-N-BF-L	LOE632-N-BL-L
22234..-K	H3134(-HG)	6,0	90 – 105	160	LOE534-N-AF-L	LOE534-N-AL-L
22234..-K	H3134(-HG)	6,0	80 – 105	160	LOE534-N-BF-L	LOE534-N-BL-L
22334..-K	H2334(-HG)	7,2	80 – 105	270	LOE634-N-AF-L	LOE634-N-AL-L
22334..-K	H2334(-HG)	7,2	80 – 105	270	LOE634-N-BF-L	LOE634-N-BL-L
22236..-K	H3136(-HG)	6,0	75 – 110	200	LOE536-N-AF-L	LOE536-N-AL-L
22236..-K	H3136(-HG)	6,0	75 – 110	200	LOE536-N-BF-L	LOE536-N-BL-L
22336..-K	H2336(-HG)	7,4	80 – 105	330	LOE636-N-AF-L	LOE636-N-AL-L
22336..-K	H2336(-HG)	7,4	80 – 105	330	LOE636-N-BF-L	LOE636-N-BL-L
22238..-K	H3138(-HG)	7,2	70 – 100	230	LOE538-N-AF-L	LOE538-N-AL-L
22238..-K	H3138(-HG)	7,2	70 – 100	230	LOE538-N-BF-L	LOE538-N-BL-L
22240..-K	H3140(-HG)	7,2	75 – 100	250	LOE540-N-AF-L	LOE540-N-AL-L
22240..-K	H3140(-HG)	7,2	75 – 100	250	LOE540-N-BF-L	LOE540-N-BL-L
22244..-K	H3144X(-HG)	8,2	80 – 110	310	LOE544-N-AF-L	LOE544-N-AL-L
22244..-K	H3144X(-HG)	8,2	80 – 110	310	LOE544-N-BF-L	LOE544-N-BL-L
22248..-K	H3148X(-HG)	8,4	100 – 120	385	LOE548-N-AF-L	LOE548-N-AL-L
22248..-K	H3148X(-HG)	8,4	100 – 120	385	LOE548-N-BF-L	LOE548-N-BL-L

Plummer block housings

LOE, split
For spherical roller bearings with cylindrical bore

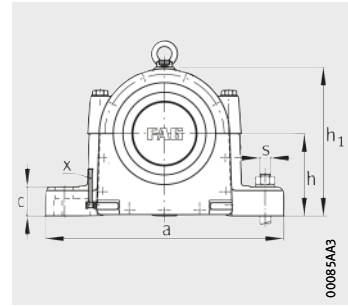
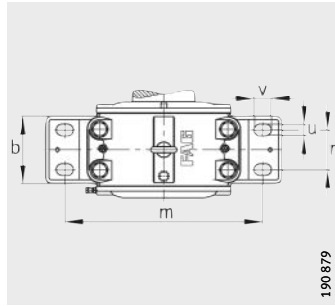

Dimension table - Dimensions in mm

Shaft			Housing Dimensions												
d	d ₂	d ₄	h	h ₁	g	g ₁	b	c	a	m	n	v	u	s	D
50	55	-	115	205	135	210	125	40	350	290	75	30	20	M16	110
50	55	47	115	205	135	210	125	40	350	290	75	30	20	M16	110
60	65	-	125	220	140	220	130	45	370	310	80	30	20	M16	130
60	65	57	125	220	140	220	130	45	370	310	80	30	20	M16	130
70	75	-	135	240	160	225	150	48	410	340	80	35	25	M20	150
70	75	67	135	240	160	225	150	48	410	340	80	35	25	M20	150
80	85	-	150	270	170	250	160	50	490	400	80	45	30	M24	170
80	85	77	150	270	170	250	160	50	490	400	80	45	30	M24	170
85	90	-	135	240	160	225	150	48	410	340	80	35	25	M20	150
85	90	82	135	240	160	225	150	48	410	340	80	35	25	M20	150
90	95	-	135	245	160	225	150	48	410	340	80	35	25	M20	160
90	95	87	135	245	160	225	150	48	410	340	80	35	25	M20	160
90	95	-	175	305	175	250	165	55	500	420	80	45	30	M24	190
90	95	87	175	305	175	250	165	55	500	420	80	45	30	M24	190
95	100	-	150	270	170	250	160	50	490	400	80	45	30	M24	170
95	100	92	150	270	170	250	160	50	490	400	80	45	30	M24	170
100	110	-	150	270	170	250	160	50	490	400	80	45	30	M24	180
100	110	97	150	270	170	250	160	50	490	400	80	45	30	M24	180
100	106	-	175	320	175	250	165	55	550	440	80	50	36	M30	215
100	106	97	175	320	175	250	165	55	550	440	80	50	36	M30	215
110	116	-	165	300	175	250	165	50	510	420	80	45	30	M24	200
110	116	107	165	300	175	250	165	50	510	420	80	45	30	M24	200
110	120	-	180	335	190	270	180	65	570	460	95	50	36	M30	240
110	120	107	180	335	190	270	180	65	570	460	95	50	36	M30	240
120	126	-	175	320	175	250	165	55	550	440	80	50	36	M30	215
120	126	117	175	320	175	250	165	55	550	440	80	50	36	M30	215
120	126	-	220	390	210	300	200	75	660	530	110	60	42	M36	260
120	126	117	220	390	210	300	200	75	660	530	110	60	42	M36	260
130	136	-	190	345	185	260	175	65	570	460	90	50	36	M30	230
130	136	127	190	345	185	260	175	65	570	460	90	50	36	M30	230
130	140	-	235	420	220	315	200	80	660	530	110	60	42	M36	280
130	140	127	235	420	220	315	200	80	660	530	110	60	42	M36	280

① Locating bearing AF; ② Non-locating bearing AL; ③ Locating bearing BF; ④ Non-locating bearing BL

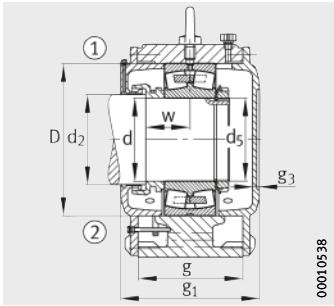

Design A

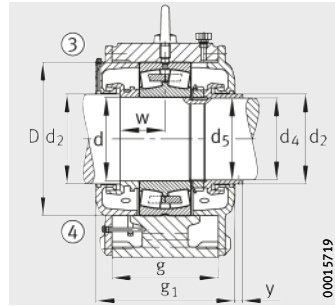

Design B



			Spherical roller bearing and accessories				Oil quantity Initial filling l	Oil level Height x mm	Housing Mass m ≈ kg	Designation	
w	y	g ₃	Bearing	Shaft nut		Tab washer				Locating bearing	Non-locating bearing
					d ₅						
52	-	18	22310	KM10	M50×2	MB10	0,9	50 - 65	30	LOE310-N-AF-L	LOE310-N-AL-L
52	15	-	22310	KM10	M50×2	MB10	0,9	50 - 65	30	LOE310-N-BF-L	LOE310-N-BL-L
55	-	18	22312	KM12	M60×2	MB12	1,0	50 - 65	35	LOE312-N-AF-L	LOE312-N-AL-L
55	15	-	22312	KM12	M60×2	MB12	1,0	50 - 65	35	LOE312-N-BF-L	LOE312-N-BL-L
62	-	18	22314	KM14	M70×2	MB14	1,4	50 - 65	45	LOE314-N-AF-L	LOE314-N-AL-L
62	15	-	22314	KM14	M70×2	MB14	1,4	50 - 65	45	LOE314-N-BF-L	LOE314-N-BL-L
67	-	18	22316	KM16	M80×2	MB16	1,6	55 - 70	60	LOE316-N-AF-L	LOE316-N-AL-L
67	15	-	22316	KM16	M80×2	MB16	1,6	55 - 70	60	LOE316-N-BF-L	LOE316-N-BL-L
62	-	18	22217	KM17	M85×2	MB17	1,4	50 - 65	45	LOE217-N-AF-L	LOE217-N-AL-L
62	15	-	22217	KM17	M85×2	MB17	1,4	50 - 65	45	LOE217-N-BF-L	LOE217-N-BL-L
61	-	17,5	22218	KM18	M90×2	MB18	1,5	45 - 60	47	LOE218-N-AF-L	LOE218-N-AL-L
61	15	-	22218	KM18	M90×2	MB18	1,5	45 - 60	47	LOE218-N-BF-L	LOE218-N-BL-L
72	-	18	22318	KM18	M90×2	MB18	2,3	65 - 85	73	LOE318-N-AF-L	LOE318-N-AL-L
72	15	-	22318	KM18	M90×2	MB18	2,3	65 - 85	73	LOE318-N-BF-L	LOE318-N-BL-L
67	-	18	22219	KM19	M95×2	MB19	1,6	55 - 70	60	LOE219-N-AF-L	LOE219-N-AL-L
67	15	-	22219	KM19	M95×2	MB19	1,6	55 - 70	60	LOE219-N-BF-L	LOE219-N-BL-L
60	-	20	22220	KM20	M100×2	MB20	1,7	50 - 65	67	LOE220-N-AF-L	LOE220-N-AL-L
60	15	-	22220	KM20	M100×2	MB20	1,7	50 - 65	67	LOE220-N-BF-L	LOE220-N-BL-L
72	-	18	22320	KM20	M100×2	MB20	2,4	55 - 75	81	LOE320-N-AF-L	LOE320-N-AL-L
72	15	-	22320	KM20	M100×2	MB20	2,4	55 - 75	81	LOE320-N-BF-L	LOE320-N-BL-L
70	-	18	22222	KM22	M110×2	MB22	2,1	50 - 70	74	LOE222-N-AF-L	LOE222-N-AL-L
70	15	-	22222	KM22	M110×2	MB22	2,1	50 - 70	74	LOE222-N-BF-L	LOE222-N-BL-L
77	-	20	22322	KM22	M110×2	MB22	2,4	45 - 65	100	LOE322-N-AF-L	LOE322-N-AL-L
77	15	-	22322	KM22	M110×2	MB22	2,4	45 - 65	100	LOE322-N-BF-L	LOE322-N-BL-L
72	-	18	22224	KM24	M120×2	MB24	2,3	50 - 70	80	LOE224-N-AF-L	LOE224-N-AL-L
72	15	-	22224	KM24	M120×2	MB24	2,3	50 - 70	80	LOE224-N-BF-L	LOE224-N-BL-L
90	-	18	22324	KM24	M120×2	MB24	4,2	65 - 90	130	LOE324-N-AF-L	LOE324-N-AL-L
90	15	-	22324	KM24	M120×2	MB24	4,2	65 - 90	130	LOE324-N-BF-L	LOE324-N-BL-L
77	-	18	22226	KM26	M130×2	MB26	2,3	55 - 75	93	LOE226-N-AF-L	LOE226-N-AL-L
77	15	-	22226	KM26	M130×2	MB26	2,3	55 - 75	93	LOE226-N-BF-L	LOE226-N-BL-L
86	-	18	22326	KM26	M130×2	MB26	3,7	75 - 105	142	LOE326-N-AF-L	LOE326-N-AL-L
86	15	-	22326	KM26	M130×2	MB26	3,7	75 - 105	142	LOE326-N-BF-L	LOE326-N-BL-L

Plummer block housings

LOE, split
For spherical roller bearings with cylindrical bore

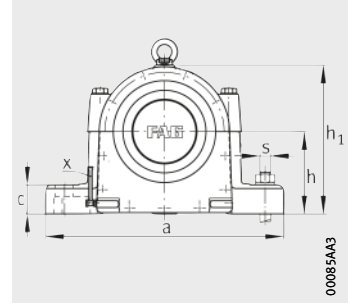
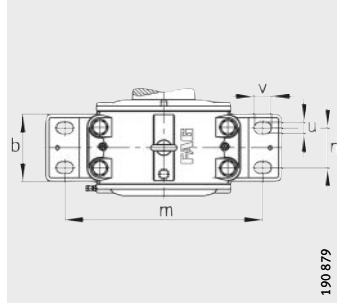

Dimension table (continued) · Dimensions in mm

Shaft			Housing Dimensions												
d	d ₂	d ₄	h	h ₁	g	g ₁	b	c	a	m	n	v	u	s	D
140	150	-	190	355	180	260	175	65	570	460	100	50	36	M30	250
140	150	137	190	355	180	260	175	65	570	460	100	50	36	M30	250
140	146	-	260	450	230	325	220	85	710	580	125	60	42	M36	300
140	146	137	260	450	230	325	220	85	710	580	125	60	42	M36	300
150	156	-	220	395	200	275	190	70	660	530	100	60	42	M36	270
150	156	147	220	395	200	275	190	70	660	530	100	60	42	M36	270
150	160	-	265	465	240	335	200	85	760	630	125	60	42	M36	320
150	160	147	265	465	240	335	200	85	760	630	125	60	42	M36	320
160	170	-	220	400	210	290	200	70	660	530	110	60	42	M36	290
160	170	155	220	400	210	290	200	70	660	530	110	60	42	M36	290
160	166	-	270	485	250	350	240	90	820	670	130	70	48	M42	340
160	166	155	270	485	250	350	240	90	820	670	130	70	48	M42	340
170	176	-	260	460	210	300	200	85	710	580	110	60	42	M36	310
170	176	165	260	460	210	300	200	85	710	580	110	60	42	M36	310
170	180	-	280	510	255	350	240	90	830	670	130	70	48	M42	360
170	180	165	280	510	255	350	240	90	830	670	130	70	48	M42	360
180	190	-	260	465	210	300	200	85	710	580	110	60	42	M36	320
180	190	175	260	465	210	300	200	85	710	580	110	60	42	M36	320
180	190	-	290	530	260	360	240	90	840	680	130	70	48	M42	380
180	190	175	290	530	260	360	240	90	840	680	130	70	48	M42	380
190	196	-	270	485	250	350	240	90	820	670	130	70	48	M42	340
190	196	185	270	485	250	350	240	90	820	670	130	70	48	M42	340
200	210	-	280	510	260	344	240	90	830	670	130	70	48	M42	360
200	210	195	280	510	260	344	240	90	830	670	130	70	48	M42	360
220	230	-	310	565	280	380	240	105	880	720	130	70	48	M42	400
220	230	212	310	565	280	380	240	105	880	720	130	70	48	M42	400
240	260	-	340	615	300	400	280	120	980	820	165	70	48	M42	440
240	260	235	340	615	300	400	280	120	980	820	165	70	48	M42	440

① Locating bearing AF; ② Non-locating bearing AL; ③ Locating bearing BF; ④ Non-locating bearing BL

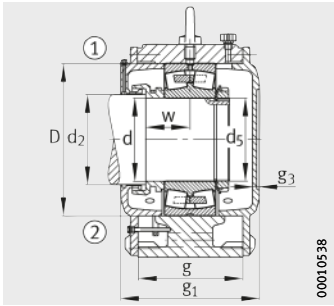

Design A

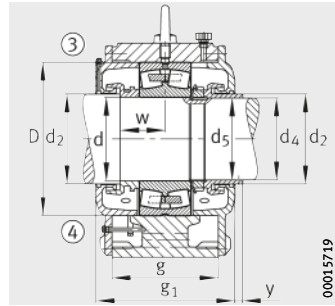

Design B



			Spherical roller bearing and accessories				Oil quantity	Oil level	Housing		
w	y	g ₃	Bearing	Shaft nut		Tab washer			Initial filling l	Height x mm	Mass m ≈ kg
					d ₅		Locating bearing	Non-locating bearing			
73	-	18	22228	KM28	M140×2	MB28	3,7	55 - 70	100	LOE228-N-AF-L	LOE228-N-AL-L
73	22	-	22228	KM28	M140×2	MB28	3,7	55 - 70	100	LOE228-N-BF-L	LOE228-N-BL-L
95	-	19,5	22328	KM28	M140×2	MB28	6,7	80 - 110	170	LOE328-N-AF-L	LOE328-N-AL-L
95	15	-	22328	KM28	M140×2	MB28	6,7	80 - 110	170	LOE328-N-BF-L	LOE328-N-BL-L
82	-	18	22230	KM30	M150×2	MB30	4,2	65 - 90	125	LOE230-N-AF-L	LOE230-N-AL-L
82	15	-	22230	KM30	M150×2	MB30	4,2	65 - 90	125	LOE230-N-BF-L	LOE230-N-BL-L
95	-	18	22330	KM30	M150×2	MB30	6,2	75 - 110	200	LOE330-N-AF-L	LOE330-N-AL-L
95	15	-	22330	KM30	M150×2	MB30	6,2	75 - 110	200	LOE330-N-BF-L	LOE330-N-BL-L
80	-	20	22232	KM32	M160×3	MB32	4,7	60 - 80	136	LOE232-N-AF-L	LOE232-N-AL-L
80	22	-	22232	KM32	M160×3	MB32	4,7	60 - 80	136	LOE232-N-BF-L	LOE232-N-BL-L
100	-	20	22332	KM32	M160×3	MB32	7,0	80 - 105	240	LOE332-N-AF-L	LOE332-N-AL-L
100	15	-	22332	KM32	M160×3	MB32	7,0	80 - 105	240	LOE332-N-BF-L	LOE332-N-BL-L
90	-	18	22234	KM34	M170×3	MB34	6,0	90 - 105	160	LOE234-N-AF-L	LOE234-N-AL-L
90	15	-	22234	KM34	M170×3	MB34	6,0	90 - 105	160	LOE234-N-BF-L	LOE234-N-BL-L
105	-	18	22334	KM34	M170×3	MB34	7,2	80 - 105	270	LOE334-N-AF-L	LOE334-N-AL-L
105	15	-	22334	KM34	M170×3	MB34	7,2	80 - 105	270	LOE334-N-BF-L	LOE334-N-BL-L
90	-	20	22236	KM36	M180×3	MB36	6,0	75 - 110	200	LOE236-N-AF-L	LOE236-N-AL-L
90	22	-	22236	KM36	M180×3	MB36	6,0	75 - 110	200	LOE236-N-BF-L	LOE236-N-BL-L
108	-	20	22336	KM36	M180×3	MB36	7,4	80 - 105	330	LOE336-N-AF-L	LOE336-N-AL-L
108	15	-	22336	KM36	M180×3	MB36	7,4	80 - 105	330	LOE336-N-BF-L	LOE336-N-BL-L
95	-	20	22238	KM38	M190×3	MB38	7,2	70 - 100	230	LOE238-N-AF-L	LOE238-N-AL-L
95	15	-	22238	KM38	M190×3	MB38	7,2	70 - 100	230	LOE238-N-BF-L	LOE238-N-BL-L
100	-	20	22240	KM40	M200×3	MB40	7,2	75 - 100	250	LOE240-N-AF-L	LOE240-N-AL-L
100	15	-	22240	KM40	M200×3	MB40	7,2	75 - 100	250	LOE240-N-BF-L	LOE240-N-BL-L
108	-	20	22244	HM44T	Tr220×4	MB44	8,2	80 - 110	310	LOE244-N-AF-L	LOE244-N-AL-L
108	15	-	22244	HM44T	Tr220×4	MB44	8,2	80 - 110	310	LOE244-N-BF-L	LOE244-N-BL-L
120	-	20	22248	HM48T	Tr240×4	MB48	8,4	100 - 125	385	LOE248-N-AF-L	LOE248-N-AL-L
120	22	-	22248	HM48T	Tr240×4	MB48	8,4	100 - 125	385	LOE248-N-BF-L	LOE248-N-BL-L



Unsplit plummer block housings

Plummer block housing units VRE3

BNM

BND

Unsplit plumber block housings

Plummer block housing units VRE3 **268**

Plummer block housing units VRE3 are completely assembled and greased bearing units that can be integrated directly in existing machinery. Plummer block housing units VRE3 were originally developed for the bearing arrangement of high speed impellers in fan applications. The units are now used wherever there is a requirement for a precise, smooth-running bearing arrangement.

The housings, which are made from flake graphite cast iron, are designed for grease lubrication. The housing body and the shaft can also be ordered individually.

The bearings used, depending on the design, are various combinations of deep groove ball bearings, cylindrical roller bearings and angular contact ball bearings.

Unsplit plumber block housings BNM **290**

Unsplit plumber block housings BNM can be used in various applications. Mills are a typical area of application.

The housings, which are made from cast steel, are designed for grease lubrication.

The housings are specifically suitable for spherical roller bearings 232 with a tapered bore that are mounted on a withdrawal sleeve.

Unsplit plumber block housings BND **300**

Unsplit plumber block housings BND are suitable for very high loads. In order to match the sealing arrangement to the operating and environmental conditions, either labyrinth or Taconite seals can be selected.

The housings are designed for grease lubrication. The standard housing material is cast steel, while a design made from spheroidal graphite cast iron is also available.

Suitable bearings are spherical roller bearings 222, 230, 231 and 232 with a tapered bore and withdrawal sleeve and with a cylindrical bore.

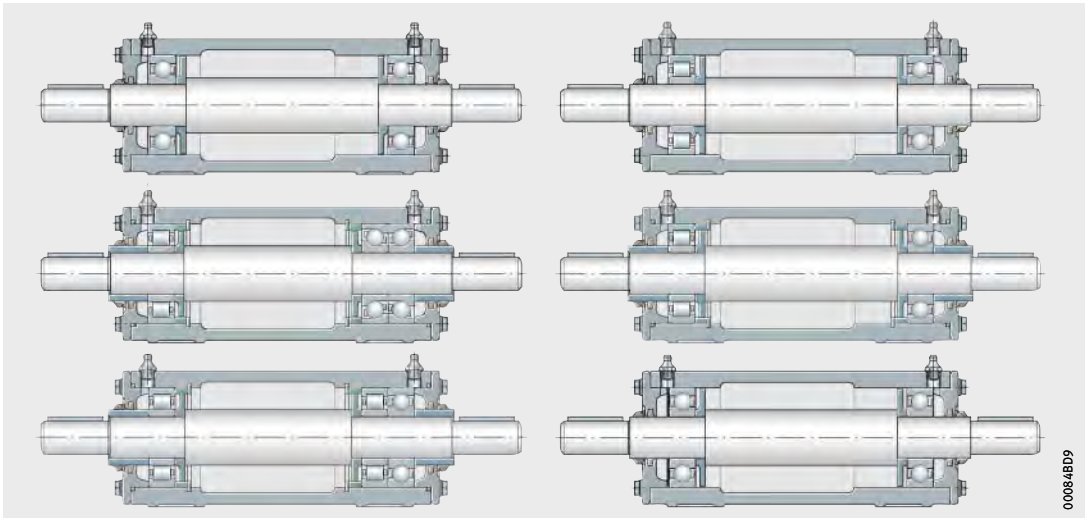

00084BD9

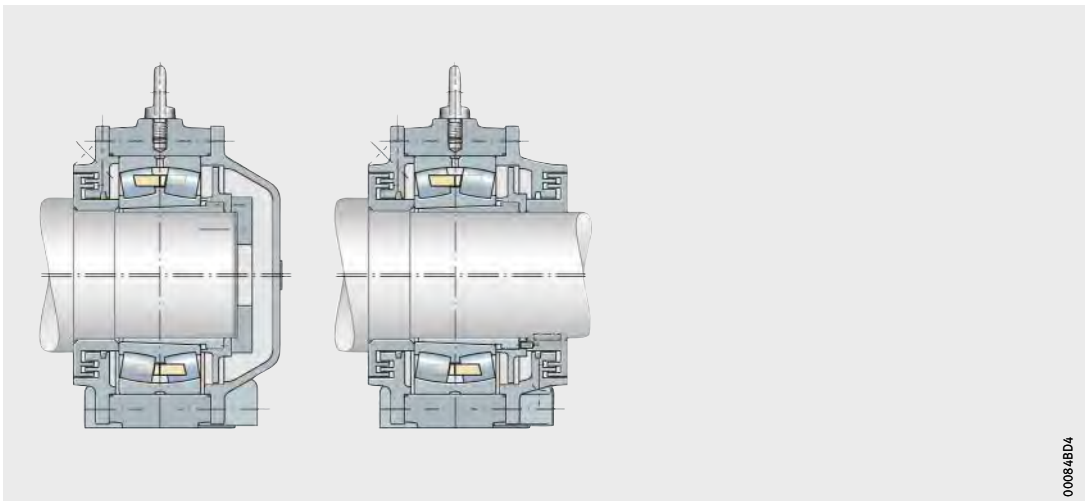

00084BD4

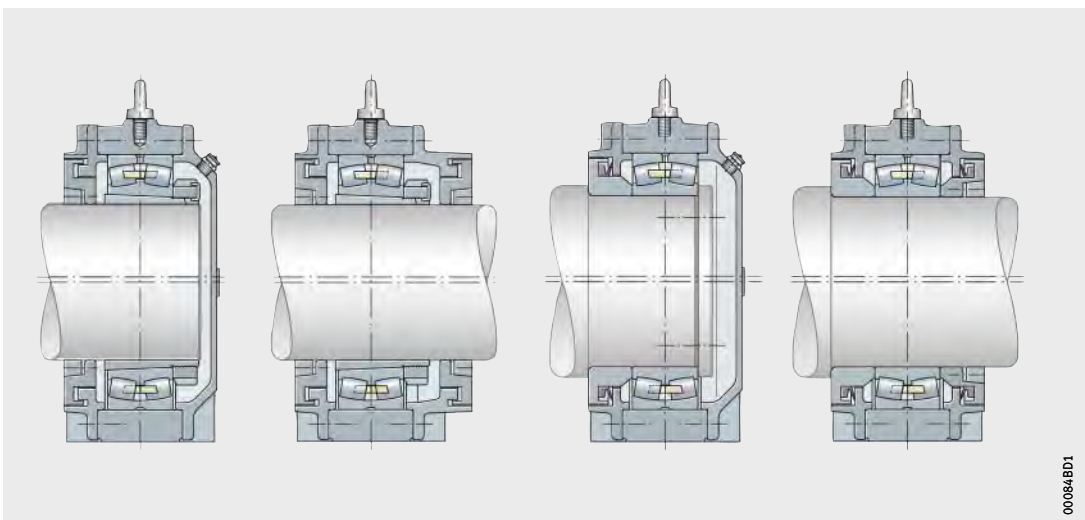

00084BD1

FAG



Plummer block housing units VRE3

Plummer block housing units VRE3

	Page
Product overview	Plummer block housing units VRE3 270
Features	Complete bearing units..... 271
	Advantages 271
	Suitable bearings 272
	Housing materials and anti-corrosion protection 272
	Seals..... 272
	Designs 273
	Areas of application of designs 275
	Lubrication 275
	Designation structure 278
	Ordering examples 280
Design and safety guidelines	Eye bolts 281
	Foot screws 281
	Marking..... 281
Accuracy 281
Dimension tables	Plummer block housing units VRE3, unsplit, with bearings and shaft 282



Product overview Plummer block housing units VRE3

Plummer block housing units
Unsplit, with bearings and shaft

VRE3



Plummer block housings
Unsplit

VR3



Shafts

VRW3

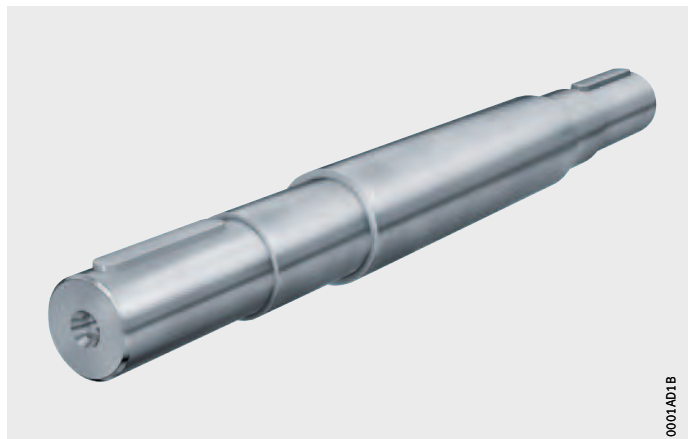

Plummer block housing units VRE3

Features Plummer block housing units VRE3 were originally developed for fan applications, for the flying bearing arrangement of high speed impellers.

The units are now used wherever there is a requirement for a precise bearing arrangement that can be easily mounted, for example in:

- conveying equipment
- test rigs
- materials processing machinery
- belt drives
- laboratory equipment
- textile machinery
- feeder mechanisms.

Complete bearing units

Plummer block housing units VRE3 comprise a tubular plummer block housing VR3 with seals and a shaft VRW3 supported in rolling bearings of dimension series 3. The units are completely assembled and the bearings are greased. The units can therefore be integrated directly in existing machinery without substantial preparation.

Plummer block housing units VRE3 are available in 6 designs for different areas of application, see page 273.



Range

The complete plummer block housing units VRE3 are available in the designs A, B, C, D, E and F with shaft diameters of 25 mm to 120 mm.

In addition, the following components are individually available:

- housings VR3 with covers, seals and locating elements
- shafts VRW3 with locating elements
- standard rolling bearings.

Advantages

Plummer block bearing units VRE3 have the following advantages:

- ease of mounting
- low maintenance requirements
- effective, low-friction sealing against dust and moisture
- bearing arrangement combined in a single-piece housing, therefore requiring no alignment work
- support of high tilting moments by two bearings with optimum spacing
- six designs allow matching to different load conditions.

Plummer block housing units VRE3

Suitable bearings

Plummer block housing units VRE3 are fitted, depending on their design, with various combinations of deep groove ball bearings, cylindrical roller bearings and angular contact ball bearings, see table. Only bearings with a cylindrical bore are fitted. The range of shaft diameters is between 25 mm and 120 mm.

Plummer block housing units and bearings

Plummer block housing unit	Bearing		
	Quantity	Bearing type	Size
VRE305A – VRE324A	2	Deep groove ball bearing	6305 – 6324
VRE305B – VRE324B	1	Cylindrical roller bearing	NJ305E – NJ324E
	1	Deep groove ball bearing	6305 – 6324
VRE305C – VRE324C	1	Cylindrical roller bearing	NU305E – NU324E
	2	Angular contact ball bearing	7305B.UA – 7324B.UA
VRE305D – VRE324D	1	Cylindrical roller bearing	NU305E – NU324E
	1	Deep groove ball bearing	6305 – 6324
VRE305E – VRE324E	2	Cylindrical roller bearing	NU305E – NU324E
	1	Deep groove ball bearing	6305 – 6324
VRE305F – VRE316F	2	Deep groove ball bearing	6305 – 6316

Housing materials and anti-corrosion protection

The housings are made from flake graphite cast iron EN-GJL-HB215. Covers and grease valves can be made from the same material or from steel S185. The shafts are made from steel E295.

All outer surfaces not machined by chip-forming methods have a universal paint coating (colour RAL 7031, bluish-grey). The coating can be finished using all synthetic resin, polyurethane, acrylic, epoxy resin, chlorinated rubber, nitrocellulose and acid-hardening hammer tone finishes.

Inner and outer surfaces of the housing body and shaft machined by chip-forming methods are provided with anti-corrosion protection that can be easily removed. It is recommended that only volatile solvents and lint-free cloths should be used.

Seals

Plummer block housing units VRE3 are sealed on both sides by a combined seal comprising a felt seal and a V ring, *Figure 1*, page 273. As a result, effective sealing against the ingress of contamination and the escape of lubricant is achieved.

The oil-soaked felt strips are inserted in the slots in the covers on the housing.

The external V rings are made from NBR and are suitable for temperatures up to +100 °C. If a circumferential velocity of more than 8 m/s is present, axial support of the V rings is necessary. At or above 12 m/s, the seal lip lifts and the V ring then acts as a splash ring.

- ① Sealing of designs A, B and F
- ② Sealing of designs C, D and E

Figure 1
Felt seal with V ring
for plummer block bearing
units VRE3

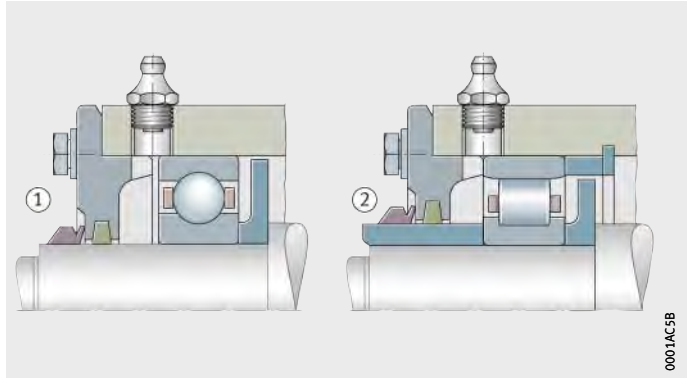

Designs

The 6 designs of plummer block housing units VRE3 represent various combinations of housings VR3, shafts VRW3 and one or more bearing types, *Figure 2 to Figure 7*, page 274.

- Housing VR3..-A
- 2 deep groove ball bearings
in floating arrangement
- Shaft VRW3..-A

Figure 2
Plummer block housing
unit VRE3..-A

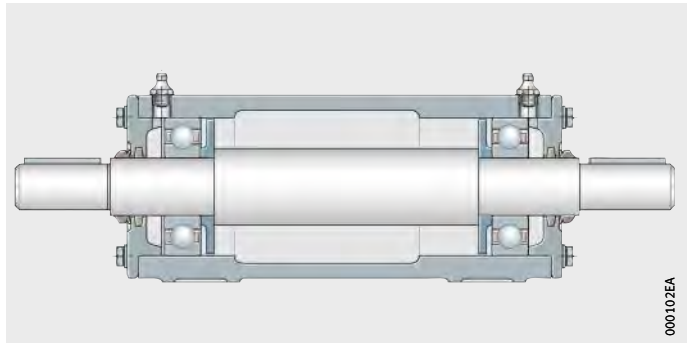

- Housing VR3..-A
- 1 deep groove ball bearing and
1 cylindrical roller bearing NJ
in floating arrangement
- Shaft VRW3..-A

Figure 3
Plummer block housing
unit VRE3..-B

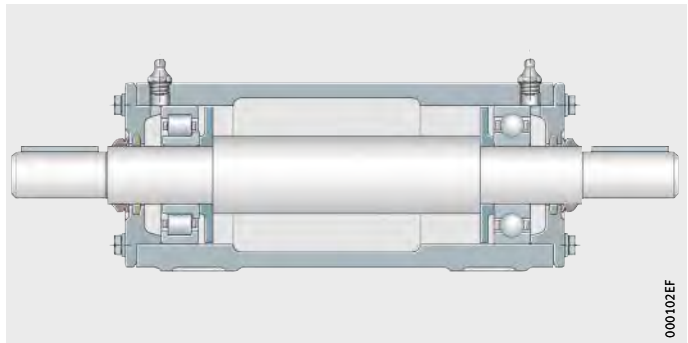

Plummer block housing units VRE3

Housing VR3...C
 Locating/non-locating bearing arrangement
 with 1 cylindrical roller bearing NU and
 2 angular contact ball bearings
 in O arrangement
 Shaft VRW3...C

Figure 4
 Plummer block housing
 unit VRE3...C

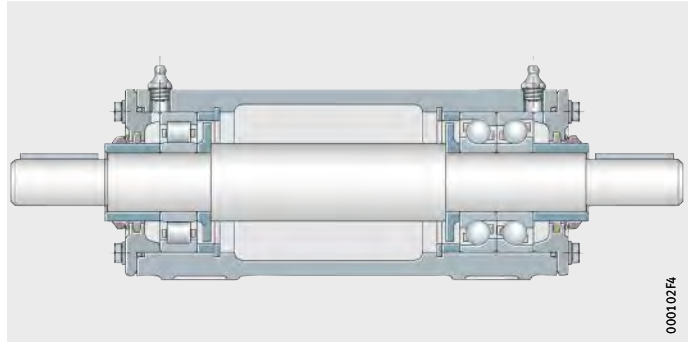

Housing VR3...D
 Locating/non-locating bearing arrangement
 with 1 cylindrical roller bearing NU and
 1 deep groove ball bearing
 Shaft VRW3...D

Figure 5
 Plummer block housing
 unit VRE3...D

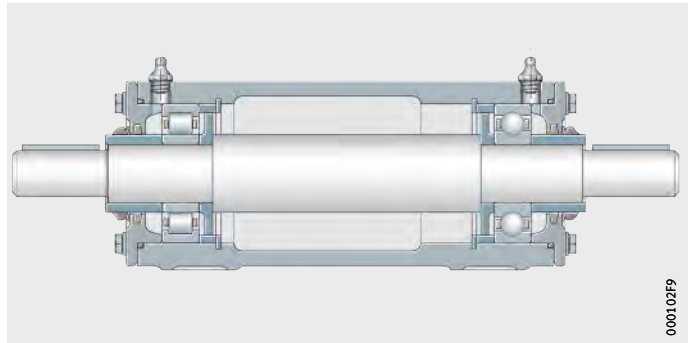

Housing VR3...E
 Locating/non-locating bearing arrangement
 with 2 cylindrical roller bearings NU and
 1 deep groove ball bearing
 Shaft VRW3...C

Figure 6
 Plummer block housing
 unit VRE3...E

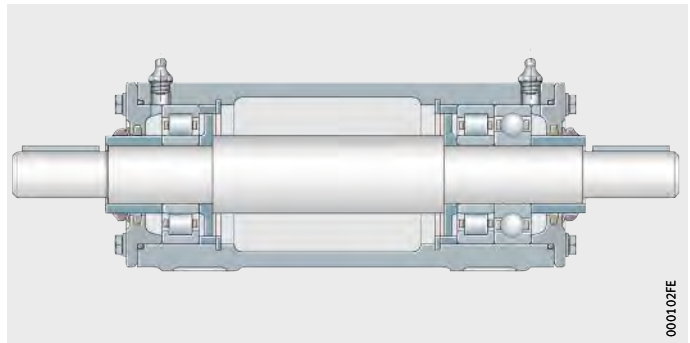

Housing VR3...F
 2 deep groove ball bearings
 in floating arrangement,
 axially adjusted by spring
 between outer ring and cover
 Shaft VRW3...F

Figure 7
 Plummer block housing
 unit VRE3...F

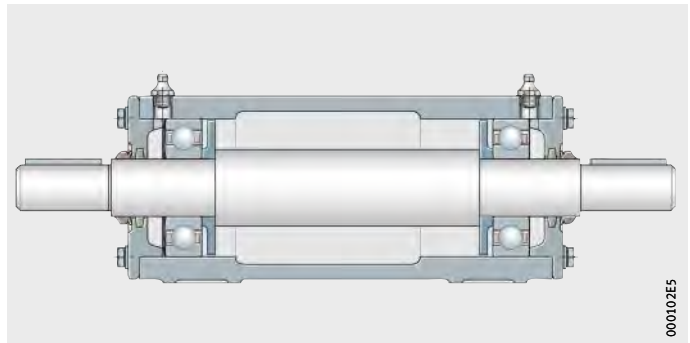

Areas of application of designs

Based on the specific bearing combination, the designs of plummer block housing units VRE3 have different areas of application.

Design A:

- predominantly radial load
- high speed
- axial load from both directions (not alternating).

Design B:

- high radial load on one side
- axial load from one direction only.

Design C:

- high radial load on one side
- high axial load from both directions.

Design D:

- axial load from both directions.

Design E:

- high radial load on both sides
- axial load from both directions.

Design F:

- predominantly radial load
- high speed
- axial load from one direction (facing away from the spring).



Maximum operating temperature

The maximum permissible operating temperature for all designs is +100 °C.

Lubrication

Plummer block housing units VRE3 are completely assembled and greased at the time of delivery.

Greases

The bearings fitted are filled with a lithium soap grease of NLGI grade 3, which has a base oil with a viscosity class ISO VG 100. For relubrication, Arcanol MULTI3 is recommended. If this grease is not available, a grease with the same oil base and NLGI grade and the most similar base oil viscosity possible should be used.

Plummer block housing units VRE3

Grease quantities

The grease quantities recommended for initial greasing are dependent on the size and design of the plummer block housing unit and the relubrication quantities are additionally dependent on the type of bearing arrangement, see table.

Recommended grease quantities for initial greasing and relubrication

Plummer block housing unit	Grease quantity			
	Initial greasing ≈ g	Relubrication		
		Non-locating bearing ≈ g	Locating bearing ≈ g	
VRE305	A, B, F	40	5	5
	C, E	45	5	10
	D	35	5	5
VRE306	A, B, F	60	5	5
	C, E	65	5	10
	D	55	5	5
VRE307	A, B, F	80	5	5
	C, E	90	5	10
	D	75	5	5
VRE308	A, B, F	110	10	10
	C, E	120	10	20
	D	100	10	10
VRE309	A, B, F	140	10	10
	C, E	155	10	20
	D	125	10	10
VRE310	A, B, F	190	10	10
	C, E	210	10	20
	D	170	10	10
VRE311	A, B, F	240	15	15
	C, E	265	15	25
	D	220	15	15
VRE312	A, B, F	300	15	15
	C, E	330	15	25
	D	270	15	15
VRE313	A, B, F	380	15	15
	C, E	420	15	25
	D	340	15	15
VRE314	A, B, F	480	20	20
	C, E	525	20	35
	D	425	20	20
VRE315	A, B, F	590	20	20
	C, E	650	20	35
	D	525	20	20
VRE316	A, B, F	700	20	20
	C, E	770	20	40
	D	620	20	20

**Recommended grease quantities
for initial greasing and relubrication
(continued)**

Plummer block housing unit	Grease quantity			
	Initial greasing	Relubrication		
		Non-locating bearing	Locating bearing	
≈ g	≈ g	≈ g		
VRE317	A, B	830	25	25
	C, E	900	25	40
	D	750	25	25
VRE318	A, B	1 000	25	25
	C, E	1 050	25	50
	D	850	25	25
VRE319	A, B	1 160	30	30
	C, E	1 300	30	55
	D	1 050	30	30
VRE320	A, B	1 450	35	35
	C, E	1 550	35	65
	D	1 250	35	35
VRE322	A, B	1 950	40	40
	C, E	1 950	40	75
	D	1 600	40	40
VRE324	A, B	2 350	45	45
	C, E	2 500	45	90
	D	2 050	45	45



Relubrication

For relubrication, each bearing position has a taper type lubrication nipple to DIN 71412-AM10×1. Overgreasing of the bearings is prevented by the washers mounted internally adjacent to the bearings. They convey the grease exiting the bearings into the free space in the housing between the bearing positions.

The relubrication intervals are dependent on the speed and design of the plummer block housing unit, see table. The values stated are valid for continuous operation.

**Relubrication intervals
for continuous operation**

Plummer block housing unit	Speed parameter $\text{min}^{-1} \cdot \text{mm}$	Relubrication interval h
VRE3 A, F	200 000	3400
	300 000	2350
	400 000	1800
B, C, D, E	200 000	1050
	300 000	600
	400 000	350

Plummer block housing units VRE3

Designation structure

The designation structure for plummer block housing units VRE3 as well as housings and shafts is shown in the tables and *Figure 8* to *Figure 10*, page 279.

Designation structure of plummer block housing units VRE3

Feature	Code	Description
① Series	VRE	Unsplit plummer block housing unit VRE3 with bearings and shaft
② Diameter series of bearing	3	Bearing of diameter series 3
③ Bore code of bearing	18	Bore diameter (18 · 5) mm = 90 mm
④ Design of housing unit	A	Design A
	B	Design B
	C	Design C
	D	Design D
	E	Design E
	F	Design F



Figure 8
Designation structure of plummer block housing units VRE3, example

Designation structure of plummer block housings VR3

Feature	Code	Description
① Series	VR	Unsplit plummer block housings VR
② Diameter series of bearing	3	Bearing of diameter series 3
③ Bore code of bearing	18	Bore diameter (18 · 5) mm = 90 mm
④ Housing design	A	Design A
	C	Design C
	D	Design D
	E	Design E
	F	Design F



Figure 9
Designation structure of plummer block housings VR3, example

Designation structure of shafts VRW3

Feature	Code	Description
① Series	VRW	Shaft VRW
② Diameter series of bearing	3	Bearing of diameter series 3
③ Bore code of bearing	18	Bore diameter (18 · 5) mm = 90 mm
④ Housing design	A	Design A
	C	Design C
	D	Design D
	F	Design F



Figure 10
Designation structure of shafts VRW3, example

Plummer block housing units VRE3

- Ordering examples** Plummer block housing units VRE3 are ideally ordered as complete units. However, it is also possible to order only the housing VR3 or only the shaft VRW3.
- The ordering examples show the construction of orders for a complete housing unit as well as for ordering only a housing and only a shaft. The allocation of housing units, housings, bearings and accessories for all housing sizes is shown in the dimension table.
- Example 1** Plummer block housing unit VRE3 of design B (rolling bearing in floating arrangement), comprising plummer block housing VR314-A, cylindrical roller bearing NJ314-E-TVP2, deep groove ball bearing 6314-C3 and shaft VRW314-A.
- Order 1 plummer block housing unit VRE314-B
- Example 2** Plummer block housing VR3 (without shaft, without rolling bearing) of design E, including covers, grease valves, lubrication nipples, seals and locating elements. The housing is suitable for a locating/non-locating bearing arrangement with 1 cylindrical roller bearing as well as 1 cylindrical roller bearing and 1 deep groove ball bearing on the opposing side.
- Order 1 plummer block housing VR322-E
- Example 3** Shaft VRW3 (without housing, without rolling bearing) of design A, including feather keys. The housing is suitable for a floating arrangement of 2 deep groove ball bearings 6314.
- Order 1 shaft VRW314-A

Design and safety guidelines

Eye bolts

Housings VR3 have two eye bolts to DIN 580. After mounting, the eye bolts can be replaced by the hexagon head bolts with seals included in the packaging.



Eye bolts must always be screwed fully into the housing.

The eye bolts must not be loaded to a value greater than the mass of the housing including the bearings and shaft.

Foot screws

Foot screws are used for screw mounting of the housings to the locating surface. They are not included in the scope of delivery of the housings.

The appropriate screw size for each housing is stated, see dimension table.

The associated tightening torques are stated for screws with a metric thread in accordance with DIN 13, DIN 962 and DIN ISO 965-2, see table, page 42.

Marking

A cast-on boss on the housing body indicates:

- the position of the cylindrical roller bearing in design B
- the position of the non-locating bearing in designs C, D and E
- the position of the ondular washer in design F.

The position of the ondular washer is also indicated on the shaft VRW3..-F.



Accuracy

In the case of plummer block housing units VRE3, the tolerance of the bearing seat is dependent on the design of the associated housing, see table.

Tolerance class of bearing seat

Design		Tolerance class of bearing seat
Plummer block housing unit VRE3	Housing VR3	
A, B	A	G6
C	C	J6
D	D	J6
E	E	J6
F	F	G6

By agreement, the housings can also be supplied with other tolerance classes for the bearing seat, see section Tolerance class of bearing seat, page 47.

Plummer block housing units

VRE3, unsplit
With bearings and shaft

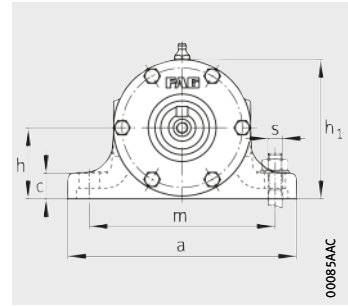

Cross-sections of designs C, D, page 285, designs E, F, page 287

Dimension table - Dimensions in mm

Shaft										Housing						
Dimensions									Designation	Dimensions						
d	d ₂	d ₄	w ₁	w ₂	w ₃	w ₄	w ₅	w ₇		h	h ₁	g ₂	b	c	a	m
25	35	19	298	-	40	90,5	117	-	VRW305-A	45	87	198	35	16	155	120
25	35	19	298	-	40	90,5	117	-	VRW305-A	45	87	198	35	16	155	120
25	35	19	298	40	42	90	101	107	VRW305-C	45	87	198	35	16	155	120
25	35	19	298	40	42	90	118	-	VRW305-D	45	87	198	35	16	155	120
25	35	19	298	40	42	90	101	107	VRW305-C	45	87	198	35	16	155	120
25	35	19	298	-	40	91,25	116,25	90,5	VRW305-F	45	87	198	35	16	155	120
30	40	24	345	-	50	102,5	140	-	VRW306-A	50	98	225	40	18	160	130
30	40	24	345	-	50	102,5	140	-	VRW306-A	50	98	225	40	18	160	130
30	40	24	349	50	52	104	122	123	VRW306-C	50	98	225	40	18	160	130
30	40	24	349	50	52	104	141	-	VRW306-D	50	98	225	40	18	160	130
30	40	24	349	50	52	104	122	123	VRW306-C	50	98	225	40	18	160	130
30	40	24	345	-	50	103,25	139,25	102,5	VRW306-F	50	98	225	40	18	160	130
35	45	28	395	-	60	117,5	160	-	VRW307-A	60	113	255	45	18	190	150
35	45	28	395	-	60	117,5	160	-	VRW307-A	60	113	255	45	18	190	150
35	45	28	399	60	62	119	140	140	VRW307-C	60	113	255	45	18	190	150
35	45	28	399	60	62	119	161	-	VRW307-D	60	113	255	45	18	190	150
35	45	28	399	60	62	119	140	140	VRW307-C	60	113	255	45	18	190	150
35	45	28	395	-	60	118,5	159	117,5	VRW307-F	60	113	255	45	18	190	150
40	50	32	501	-	80	143,5	214	-	VRW308-A	60	118	317	52	20	190	150
40	50	32	501	-	80	143,5	214	-	VRW308-A	60	118	317	52	20	190	150
40	50	32	501	80	82	143	192	166	VRW308-C	60	118	317	52	20	190	150
40	50	32	501	80	82	143	215	-	VRW308-D	60	118	317	52	20	190	150
40	50	32	501	80	82	143	192	166	VRW308-C	60	118	317	52	20	190	150
40	50	32	501	-	80	144,5	213	143,5	VRW308-F	60	118	317	52	20	190	150

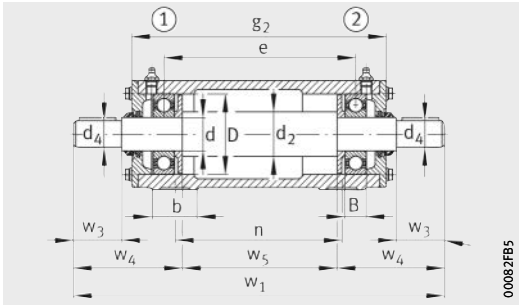

VRE3...-A

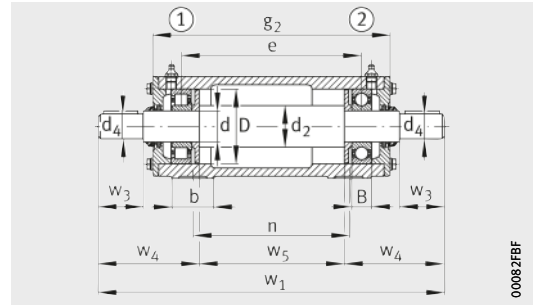

VRE3...-B

					Mass m ≈ kg	Designation	Bearing		Plummer block housing unit	
n	s	D	B	e			Bearing position ①	Bearing position ②	Mass m ≈ kg	Designation Unit
135	M12	62	17	148	5	VR305-A			6305-C3	6305-C3
135	M12	62	17	149	5	VR305-A	NJ305-E-TVP2	6305-C3	7	VRE305-B
135	M12	62	17	140,5	5,2	VR305-C	NU305-E-TVP2-C3	2X7305-B-TVP-UA	7,4	VRE305-C
135	M12	62	17	149	5,2	VR305-D	NU305-E-TVP2-C3	6305-C3	7,2	VRE305-D
135	M12	62	17	132	5,2	VR305-E	NU305-E-TVP2-C3	NU305-E-TVP2-C3+6305-C3	7,5	VRE305-E
135	M12	62	17	147,25	5	VR305-F	6305-C3	6305-C3	7	VRE305-F
150	M12	72	19	173	5,8	VR306-A	6306-C3	6306-C3	9	VRE306-A
150	M12	72	19	174	5,8	VR306-A	NJ306-E-TVP2	6306-C3	9	VRE306-B
150	M12	72	19	164,5	6	VR306-C	NU306-E-TVP2-C3	2X7306-B-TVP-UA	9,4	VRE306-C
150	M12	72	19	174	6	VR306-D	NU306-E-TVP2-C3	6306-C3	9,2	VRE306-D
150	M12	72	19	155	6	VR306-E	NU306-E-TVP2-C3	NU306-E-TVP2-C3+6306-C3	9,4	VRE306-E
150	M12	72	19	172,25	5,8	VR306-F	6306-C3	6306-C3	9	VRE306-F
175	M12	80	21	197	8,5	VR307-A	6307-C3	6307-C3	13	VRE307-A
175	M12	80	21	198	8,5	VR307-A	NJ307-E-TVP2	6307-C3	13	VRE307-B
175	M12	80	21	187,5	8,8	VR307-C	NU307-E-TVP2-C3	2X7307-B-TVP-UA	13,6	VRE307-C
175	M12	80	21	198	8,8	VR307-D	NU307-E-TVP2-C3	6307-C3	13,3	VRE307-D
175	M12	80	21	177	8,8	VR307-E	NU307-E-TVP2-C3	NU307-E-TVP2-C3+6307-C3	13,6	VRE307-E
175	M12	80	21	196	8,5	VR307-F	6307-C3	6307-C3	13	VRE307-F
225	M12	90	23	257	10,9	VR308-A	6308-C3	6308-C3	18	VRE308-A
225	M12	90	23	258	10,9	VR308-A	NJ308-E-TVP2	6308-C3	18	VRE308-B
225	M12	90	23	246,5	11,7	VR308-C	NU308-E-TVP2-C3	2X7308-B-TVP-UA	19,1	VRE308-C
225	M12	90	23	258	11,7	VR308-D	NU308-E-TVP2-C3	6308-C3	18,8	VRE308-D
225	M12	90	23	235	11,7	VR308-E	NU308-E-TVP2-C3	NU308-E-TVP2-C3+6308-C3	19,2	VRE308-E
225	M12	90	23	256	10,9	VR308-F	6308-C3	6308-C3	18	VRE308-F



Plummer block housing units

VRE3, unsplit
With bearings and shaft

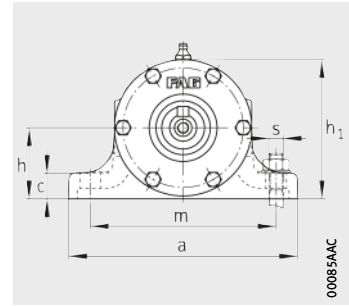

Cross-sections of designs A, B, page 283, designs E, F, page 287

Dimension table (continued) · Dimensions in mm

Shaft										Housing						
Dimensions									Designation	Dimensions						
d	d ₂	d ₄	w ₁	w ₂	w ₃	w ₄	w ₅	w ₇		h	h ₁	g ₂	b	c	a	m
45	55	38	527	–	80	145,5	236	–	VRW309-A	70	135	343	52	22	210	170
45	55	38	527	–	80	145,5	236	–	VRW309-A	70	135	343	52	22	210	170
45	55	38	527	80	82	145	212	170	VRW309-C	70	135	343	52	22	210	170
45	55	38	527	80	82	145	237	–	VRW309-D	70	135	343	52	22	210	170
45	55	38	527	80	82	145	212	170	VRW309-C	70	135	343	52	22	210	170
45	55	38	527	–	80	146,5	235	145,5	VRW309-F	70	135	343	52	22	210	170
50	60	42	625	–	110	179,5	266	–	VRW310-A	70	138	381	60	25	210	170
50	60	42	625	–	110	179,5	266	–	VRW310-A	70	138	381	60	25	210	170
50	60	42	625	110	112	179	240	206	VRW310-C	70	138	381	60	25	210	170
50	60	42	625	110	112	179	267	–	VRW310-D	70	138	381	60	25	210	170
50	60	42	625	110	112	179	240	206	VRW310-C	70	138	381	60	25	210	170
50	60	42	625	–	110	180,5	265	179,5	VRW310-F	70	138	381	60	25	210	170
55	65	48	651	–	110	181,5	288	–	VRW311-A	80	158	407	60	25	260	210
55	65	48	651	–	110	181,5	288	–	VRW311-A	80	158	407	60	25	260	210
55	65	48	651	110	112	181	260	210	VRW311-C	80	158	407	60	25	260	210
55	65	48	651	110	112	181	289	–	VRW311-D	80	158	407	60	25	260	210
55	65	48	651	110	112	181	260	210	VRW311-C	80	158	407	60	25	260	210
55	65	48	651	–	110	182,5	287	181,5	VRW311-F	80	158	407	60	25	260	210
60	70	48	701	–	110	183,5	334	–	VRW312-A	80	162	457	70	25	260	210
60	70	48	701	–	110	183,5	334	–	VRW312-A	80	162	457	70	25	260	210
60	70	48	706	110	112	185,5	304	216,5	VRW312-C	80	162	457	70	25	260	210
60	70	48	706	110	112	185,5	335	–	VRW312-D	80	162	457	70	25	260	210
60	70	48	706	110	112	185,5	304	216,5	VRW312-C	80	162	457	70	25	260	210
60	70	48	701	–	110	184,5	333	183,5	VRW312-F	80	162	457	70	25	260	210

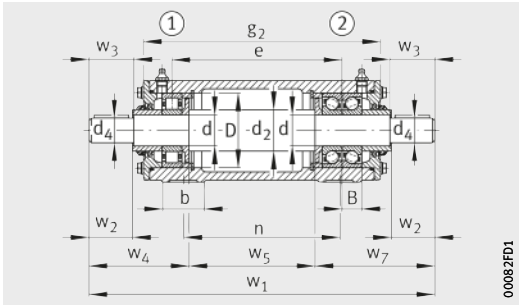

VRE3...-C

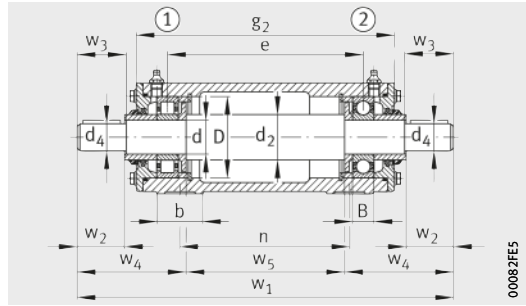

VRE3...-D

n	s	D	B	e	Mass m ≈ kg	Designation	Bearing		Plummer block housing unit	
							Designation		Mass m ≈ kg	Designation Unit
							Bearing position ①	Bearing position ②		
250	M12	100	25	281	14,9	VR309-A	6309-C3	6309-C3	24,3	VRE309-A
250	M12	100	25	282	14,9	VR309-A	NJ309-E-TVP2	6309-C3	24,4	VRE309-B
250	M12	100	25	269,5	15,3	VR309-C	NU309-E-TVP2-C3	2X7309-B-TVP-UA	25,3	VRE309-C
250	M12	100	25	282	15,3	VR309-D	NU309-E-TVP2-C3	6309-C3	24,8	VRE309-D
250	M12	100	25	257	15,3	VR309-E	NU309-E-TVP2-C3	NU309-E-TVP2-C3+6309-C3	25,3	VRE309-E
250	M12	100	25	280	14,9	VR309-F	6309-C3	6309-C3	24,2	VRE309-F
275	M12	110	27	313	17,3	VR310-A	6310-C3	6310-C3	30,3	VRE310-A
275	M12	110	27	314	17,3	VR310-A	NJ310-E-TVP2	6310-C3	30,3	VRE310-B
275	M12	110	27	300,5	17,9	VR310-C	NU310-E-TVP2-C3	2X7310-B-TVP-UA	31,7	VRE310-C
275	M12	110	27	314	17,9	VR310-D	NU310E-TVP2-C3	6310-C3	30,9	VRE310-D
275	M12	110	27	287	17,9	VR310-E	NU310-E-TVP2-C3	NU310-E-TVP2-C3+6310-C3	31,8	VRE310-E
275	M12	110	27	312	17,3	VR310-F	6310-C3	6310-C3	30,3	VRE310-F
300	M16	120	29	337	22	VR311-A	6311-C3	6311-C3	38,6	VRE311-A
300	M16	120	29	338	22	VR311-A	NJ311-E-TVP2	6311-C3	38,7	VRE311-B
300	M16	120	29	323,5	22,5	VR311-C	NU311-E-TVP2-C3	2X7311-B-TVP-UA	40,2	VRE311-C
300	M16	120	29	338	22,5	VR311-D	NU311-E-TVP2-C3	6311-C3	39,2	VRE311-D
300	M16	120	29	309	22,5	VR311-E	NU311-E-TVP2-C3	NU311-E-TVP2-C3+6311-C3	40,2	VRE311-E
300	M16	120	29	336	22	VR311-F	6311-C3	6311-C3	38,6	VRE311-F
340	M16	130	31	385	30,7	VR312-A	6312-C3	6312-C3	51,2	VRE312-A
340	M16	130	31	386	30,7	VR312-A	NJ312-E-TVP2	6312-C3	51,4	VRE312-B
340	M16	130	31	370,5	31,7	VR312-C	NU312-E-TVP2-C3	2X7312-B-TVP-UA	53,8	VRE312-C
340	M16	130	31	386	31,7	VR312-D	NU312-E-TVP2-C3	6312-C3	52,4	VRE312-D
340	M16	130	31	355	31,7	VR312-E	NU312-E-TVP2-C3	NU312-E-TVP2-C3+6312-C3	53,7	VRE312-E
340	M16	130	31	384	30,7	VR312-F	6312-C3	6312-C3	51,1	VRE312-F



Plummer block housing units

VRE3, unsplit
With bearings and shaft

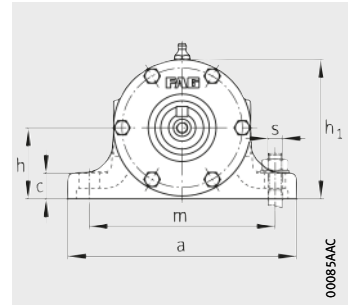

Cross-sections of designs A, B, page 283, designs C, D, page 285

Dimension table (continued) · Dimensions in mm

Shaft									Housing							
Dimensions									Designation	Dimensions						
d	d ₂	d ₄	w ₁	w ₂	w ₃	w ₄	w ₅	w ₇		h	h ₁	g ₂	b	c	a	m
65	75	55	724	–	110	187,5	349	–	VRW313-A	95	183	480	70	25	290	230
65	75	55	724	–	110	187,5	349	–	VRW313-A	95	183	480	70	25	290	230
65	75	55	729	110	112	189,5	317	222,5	VRW313-C	95	183	480	70	25	290	230
65	75	55	729	110	112	189,5	350	–	VRW313-D	95	183	480	70	25	290	230
65	75	55	729	110	112	189,5	317	222,5	VRW313-C	95	183	480	70	25	290	230
65	75	55	724	–	110	189	347,5	187,5	VRW313-F	95	183	480	70	25	290	230
70	80	60	811	–	140	223	365	–	VRW314-A	95	188	500	70	25	290	230
70	80	60	811	–	140	223	365	–	VRW314-A	95	188	500	70	25	290	230
70	80	60	811	140	143	222,5	331	257,5	VRW314-C	95	188	500	70	25	290	230
70	80	60	811	140	143	222,5	366	–	VRW314-D	95	188	500	70	25	290	230
70	80	60	811	140	143	222,5	331	257,5	VRW314-C	95	188	500	70	25	290	230
70	80	60	811	–	140	224,5	363,5	223	VRW314-F	95	188	500	70	25	290	230
75	90	65	841	–	140	226	389	–	VRW315-A	100	198	530	80	30	320	260
75	90	65	841	–	140	226	389	–	VRW315-A	100	198	530	80	30	320	260
75	90	65	841	140	143	225,5	353	262,5	VRW315-C	100	198	530	80	30	320	260
75	90	65	841	140	143	225,5	390	–	VRW315-D	100	198	530	80	30	320	260
75	90	65	841	140	143	225,5	353	262,5	VRW315-C	100	198	530	80	30	320	260
75	90	65	841	–	140	227,5	387,5	226	VRW315-F	100	198	530	80	30	320	260
80	95	70	861	–	140	228	405	–	VRW316-A	112	217	550	80	30	320	260
80	95	70	861	–	140	228	405	–	VRW316-A	112	217	550	80	30	320	260
80	95	70	861	140	143	227,5	367	266,5	VRW316-C	112	217	550	80	30	320	260
80	95	70	861	140	143	227,5	406	–	VRW316-D	112	217	550	80	30	320	260
80	95	70	861	140	143	227,5	367	266,5	VRW316-C	112	217	550	80	30	320	260
80	95	70	861	–	140	229,5	403,5	228	VRW316-F	112	217	550	80	30	320	260
85	100	75	881	–	140	230	421	–	VRW317-A	112	222	570	80	30	350	290
85	100	75	881	–	140	230	421	–	VRW317-A	112	222	570	80	30	350	290
85	100	75	881	140	143	229,5	381	270,5	VRW317-C	112	222	570	80	30	350	290
85	100	75	881	140	143	229,5	422	–	VRW317-D	112	222	570	80	30	350	290
85	100	75	881	140	143	229,5	381	270,5	VRW317-C	112	222	570	80	30	350	290

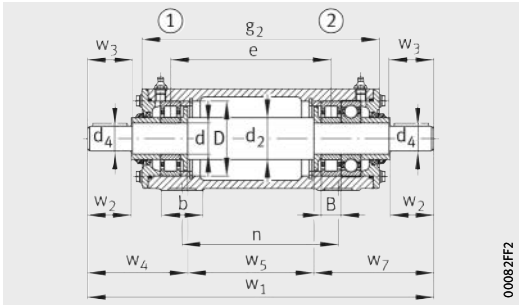

00082FF2

VRE3...-E

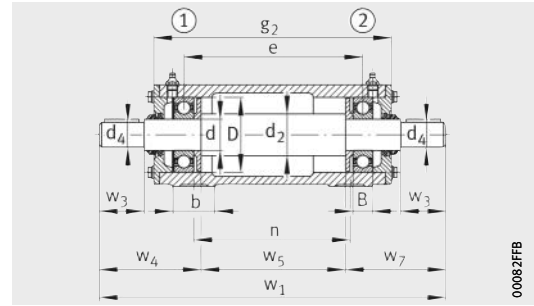

00082FFB

VRE3...-F

					Mass m ≈ kg	Designation	Bearing		Plummer block housing unit		
n	s	D	B	e			Designation	Designation		Mass m ≈ kg	Designation Unit
								Bearing position ①	Bearing position ②		
360	M16	140	33	404	32,8	VR313-A	6313-C3	6313-C3	58	VRE313-A	
360	M16	140	33	405	32,8	VR313-A	NJ313-E-TVP2	6313-C3	58,2	VRE313-B	
360	M16	140	33	388,5	33,8	VR313-C	NU313-E-TVP2-C3	2X7313-B-TVP-UA	60,8	VRE313-C	
360	M16	140	33	405	33,8	VR313-D	NU313-E-TVP2-C3	6313-C3	59,3	VRE313-D	
360	M16	140	33	372	33,8	VR313-E	NU313-E-TVP2-C3	NU313-E-TVP2-C3+6313-C3	60,8	VRE313-E	
360	M16	140	33	402,5	32,8	VR313-F	6313-C3	6313-C3	58	VRE313-F	
380	M16	150	35	422	35	VR314-A	6314-C3	6314-C3	66,9	VRE314-A	
380	M16	150	35	423	35	VR314-A	NJ314-E-TVP2	6314-C3	67,1	VRE314-B	
380	M16	150	35	405,5	36	VR314-C	NU314-E-TVP2-C3	2X7314-B-TVP-UA	70,4	VRE314-C	
380	M16	150	35	423	36	VR314-D	NU314-E-TVP2-C3	6314-C3	68	VRE314-D	
380	M16	150	35	388	36	VR314-E	NU314-E-TVP2-C3	NU314-E-TVP2-C3+6314-C3	70,6	VRE314-E	
380	M16	150	35	420,5	35	VR314-F	6314-C3	6314-C3	66,8	VRE314-F	
400	M16	160	37	450	44,8	VR315-A	6315-C3	6315-C3	84,8	VRE315-A	
400	M16	160	37	451	44,8	VR315-A	NJ315-E-TVP2	6315-C3	85	VRE315-B	
400	M16	160	37	432,5	46,4	VR315-C	NU315-E-TVP2-C3	2X7315-B-TVP-UA	89,3	VRE315-C	
400	M16	160	37	451	46,4	VR315-D	NU315-E-TVP2-C3	6315-C3	86,4	VRE315-D	
400	M16	160	37	414	46,4	VR315-E	NU315-E-TVP2-C3	NU315-E-TVP2-C3+6315-C3	89,4	VRE315-E	
400	M16	160	37	448,5	44,8	VR315-F	6315-C3	6315-C3	84,8	VRE315-F	
420	M16	170	39	468	44	VR316-A	6316-C3	6316-C3	90,8	VRE316-A	
420	M16	170	39	469	44	VR316-A	NJ316-E-TVP2	6316-C3	91	VRE316-B	
420	M16	170	39	449,5	45	VR316-C	NU316-E-TVP2-C3	2X7316-B-TVP-UA	96,2	VRE316-C	
420	M16	170	39	469	45	VR316-D	NU316-E-TVP2-C3	6316-C3	91,9	VRE316-D	
420	M16	170	39	430	45	VR316-E	NU316-E-TVP2-C3	NU316-E-TVP2-C3+6316-C3	95,3	VRE316-E	
420	M16	170	39	466,5	44	VR316-F	6316-C3	6316-C3	90,8	VRE316-F	
440	M16	180	41	486	59,2	VR317-A	6317-C3	6317-C3	114	VRE317-A	
440	M16	180	41	487	59,2	VR317-A	NJ317-E-TVP2	6317-C3	115	VRE317-B	
440	M16	180	41	466,5	60	VR317-C	NU317-E-TVP2-C3	2X7317-B-TVP-UA	120	VRE317-C	
440	M16	180	41	487	60	VR317-D	NU317-E-TVP2-C3	6317-C3	115	VRE317-D	
440	M16	180	41	446	60	VR317-E	NU317-E-TVP2-C3	NU317-E-TVP2-C3+6317-C3	120	VRE317-E	



Plummer block housing units

VRE3, unsplit
With bearings and shaft

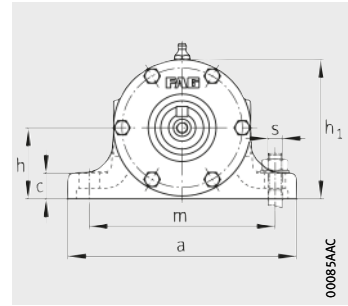

Cross-sections of designs C, D, page 285, design E, page 287

Dimension table (continued) · Dimensions in mm

Shaft									Housing							
Dimensions									Designation	Dimensions						
d	d ₂	d ₄	w ₁	w ₂	w ₃	w ₄	w ₅	w ₇		h	h ₁	g ₂	b	c	a	m
90	105	80	971	–	170	263	445	–	VRW318-A	112	227	600	85	30	350	290
90	105	80	971	–	170	263	445	–	VRW318-A	112	227	600	85	30	350	290
90	105	80	975	170	173	264,5	403	307,5	VRW318-C	112	227	600	85	30	350	290
90	105	80	975	170	173	264,5	446	–	VRW318-D	112	227	600	85	30	350	290
90	105	80	975	170	173	264,5	403	307,5	VRW318-C	112	227	600	85	30	350	290
95	110	85	1004	–	170	267,5	469	–	VRW319-A	125	248	633	90	35	400	320
95	110	85	1004	–	170	267,5	469	–	VRW319-A	125	248	633	90	35	400	320
95	110	85	1008	170	173	269	425	314	VRW319-C	125	248	633	90	35	400	320
95	110	85	1008	170	173	269	470	–	VRW319-D	125	248	633	90	35	400	320
95	110	85	1008	170	173	269	425	314	VRW319-C	125	248	633	90	35	400	320
100	120	90	1036	–	170	268	500	–	VRW320-A	130	260	665	95	40	400	320
100	120	90	1036	–	170	268	500	–	VRW320-A	130	260	665	95	40	400	320
100	120	90	1040	170	173	269,5	454	316,5	VRW320-C	130	260	665	95	40	400	320
100	120	90	1040	170	173	269,5	501	–	VRW320-D	130	260	665	95	40	400	320
100	120	90	1040	170	173	269,5	454	316,5	VRW320-C	130	260	665	95	40	400	320
110	130	100	1133	–	210	313	507	–	VRW322-A	150	295	678	95	40	450	380
110	130	100	1133	–	210	313	507	–	VRW322-A	150	295	678	95	40	450	380
110	130	100	1133	210	213	312,5	458	362,5	VRW322-C	150	295	678	95	40	450	380
110	130	100	1133	210	213	312,5	508	–	VRW322-D	150	295	678	95	40	450	380
110	130	100	1133	210	213	312,5	458	362,5	VRW322-C	150	295	678	95	40	450	380
120	140	110	1160	–	210	318	524	–	VRW324-A	160	320	705	100	40	500	410
120	140	110	1160	–	210	318	524	–	VRW324-A	160	320	705	100	40	500	410
120	140	110	1160	210	213	317,5	470	372,5	VRW324-C	160	320	705	100	40	500	410
120	140	110	1160	210	213	317,5	525	–	VRW324-D	160	320	705	100	40	500	410
120	140	110	1160	210	213	317,5	470	372,5	VRW324-C	160	320	705	100	40	500	410

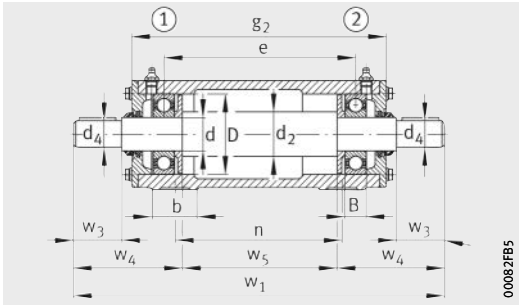

VRE3...-A

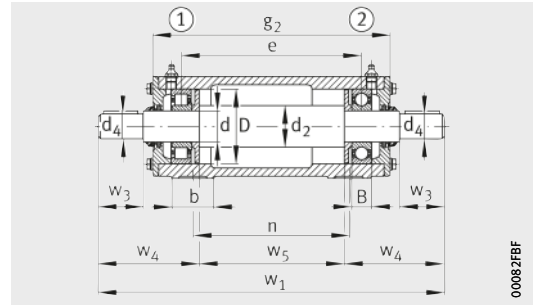

VRE3...-B

					Mass m ≈ kg	Designation	Bearing		Plummer block housing unit	
n	s	D	B	e			Bearing position ①	Bearing position ②	Mass	Designation
460	M16	190	43	510	62	VR318-A	6318-C3	6318-C3	128	VRE318-A
460	M16	190	43	511	62	VR318-A	NJ318-E-TVP2	6318-C3	128	VRE318-B
460	M16	190	43	489,5	63	VR318-C	NU318-E-TVP2-C3	2X7318-B-TVP-UA	134	VRE318-C
460	M16	190	43	511	63	VR318-D	NU318-E-TVP2-C3	6318-C3	129	VRE318-D
460	M16	190	43	468	63	VR318-E	NU318-E-TVP2-C3	NU318-E-TVP2-C3+6318-C3	134	VRE318-E
480	M20	200	45	540	84	VR319-A	6319-C3	6319-C3	156	VRE319-A
480	M20	200	45	541	84	VR319-A	NJ319-E-TVP2	6319-C3	157	VRE319-B
480	M20	200	45	518,5	86	VR319-C	NU319-E-TVP2-C3	2X7319-B-TVP-UA	164	VRE319-C
480	M20	200	45	541	86	VR319-D	NU319-E-TVP2-C3	6319-C3	158	VRE319-D
480	M20	200	45	496	86	VR319-E	NU319-E-TVP2-C3	NU319-E-TVP2-C3+6319-C3	164	VRE319-E
500	M20	215	47	570	90	VR320-A	6320-C3	6320-C3	177	VRE320-A
500	M20	215	47	571	90	VR320-A	NJ320-E-TVP2	6320-C3	177	VRE320-B
500	M20	215	47	547,5	92	VR320-C	NU320-E-TVP2-C3	2X7320-B-TVP-UA	186	VRE320-C
500	M20	215	47	571	92	VR320-D	NU320-E-TVP2-C3	6320-C3	179	VRE320-D
500	M20	215	47	524	92	VR320-E	NU320-E-TVP2-C3	NU320-E-TVP2-C3+6320-C3	186	VRE320-E
520	M24	240	50	580	130	VR322-A	6322-C3	6322-C3	226	VRE322-A
520	M24	240	50	581	130	VR322-A	NJ322-E-TVP2	6322-C3	226	VRE322-B
520	M24	240	50	556	132	VR322-C	NU322-E-TVP2-C3	2X7322-B-TVP-UA	238	VRE322-C
520	M24	240	50	581	132	VR322-D	NU322-E-TVP2-C3	6322-C3	228	VRE322-D
520	M24	240	50	531	132	VR322-E	NU322-E-TVP2-C3	NU322-E-TVP2-C3+6322-C3	238	VRE322-E
540	M24	260	55	602	170	VR324-A	6324-C3	6324-C3	276	VRE324-A
540	M24	260	55	603	170	VR324-A	NJ324-E-TVP2	6324-C3	277	VRE324-B
540	M24	260	55	575,5	172	VR324-C	NU324-E-TVP2-C3	2X7324-B-TVP-UA	294	VRE324-C
540	M24	260	55	603	172	VR324-D	NU324-E-TVP2-C3	6324-C3	278	VRE324-D
540	M24	260	55	548	172	VR324-E	NU324-E-TVP2-C3	NU324-E-TVP2-C3+6324-C3	291	VRE324-E



FAG

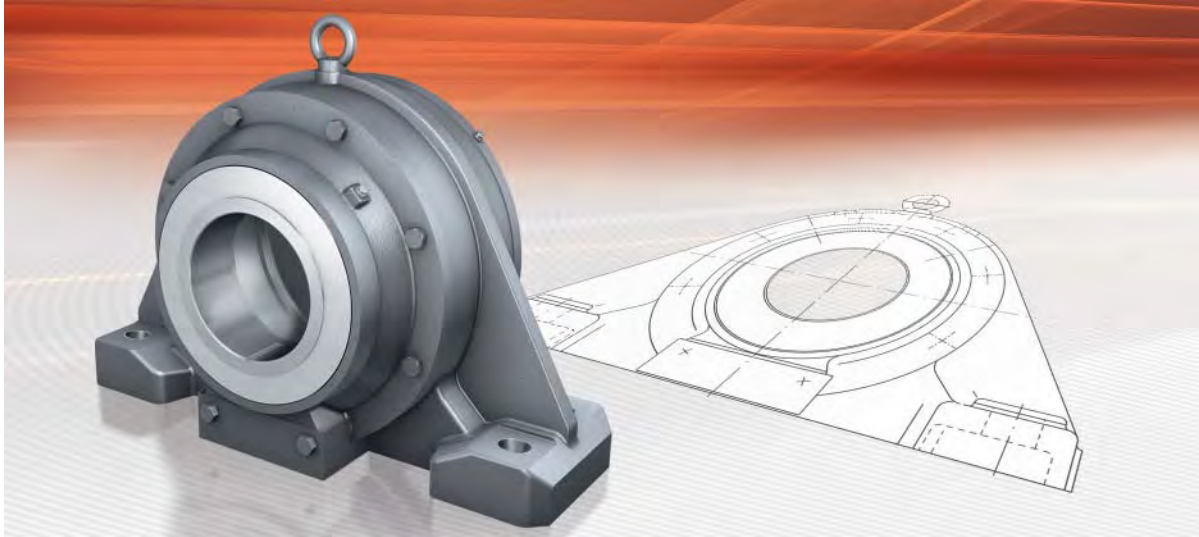

Unsplit plummer block housings BNM

Unsplit plummer block housings BNM

	Page
Product overview	Unsplit plummer block housings BNM..... 292
Features	Suitable bearings 293
	Housing material and anti-corrosion protection..... 293
	Locating and non-locating bearings 293
	Seals and covers 294
	Housing configurations..... 295
	Lubrication 295
	Designation structure 296
	Ordering example 296
Design and safety guidelines	Eye bolts 297
	Foot screws 297
Accuracy 297
Dimension tables	Plummer block housings BNM, unsplit, for spherical roller bearings with tapered bore and withdrawal sleeve, stepped shaft..... 298



Product overview Unsplit plummer block housings BNM

Plummer block housings

Unsplit

Closed on one side, with cover

BNM...-AF, BNM...-AL



00081E98

For continuous shaft

BNM...-BF, BNM...-BL



00081E94

Unsplit plummer block housings BNM

Features Unsplit plummer block housings BNM can be used in various applications. Mills are a typical area of application.

Suitable bearings The dimensions of split plummer block housings BNM are matched to spherical roller bearings 232..-K, see table. The range of shaft diameters is between 150 mm and 400 mm.

Bearing type and sizes

Bearing type	Size
Spherical roller bearings ■ with tapered bore and withdrawal sleeve	23232..-K to 23284..K

Housing material and anti-corrosion protection

The housing bodies are made from cast steel.

All outer surfaces not machined by chip-forming methods have a universal paint coating (colour RAL 7031, bluish-grey). The coating can be finished using all synthetic resin, polyurethane, acrylic, epoxy resin, chlorinated rubber, nitrocellulose and acid-hardening hammer tone finishes.

Inner and outer surfaces machined by chip-forming methods are provided with anti-corrosion protection that can be easily removed. It is recommended that only volatile solvents and lint-free cloths should be used.



Locating and non-locating bearings

The housings are supplied as a locating bearing design or non-locating bearing design. In the locating bearing, the bearing is clamped between the housing covers. In the non-locating bearing, the bearing can align itself axially, since the covers have shorter centring collars.

Unsplit plummer block housings BNM

Seals and covers

Plummer block housings BNM of design A are intended for the bearing arrangements of shaft ends. One side is closed by a cover and the other side is sealed against the shaft. Design B is intended for continuous shafts, in which case the housing is sealed against the shaft on both sides.

The seal is a combination of a labyrinth seal and a felt seal, *Figure 1*. The oil-soaked felt strip is inserted in the slot in the outer labyrinth ring. The labyrinth rings are unsplit. The seal allows shaft misalignment of up to $0,5^\circ$ in both directions.

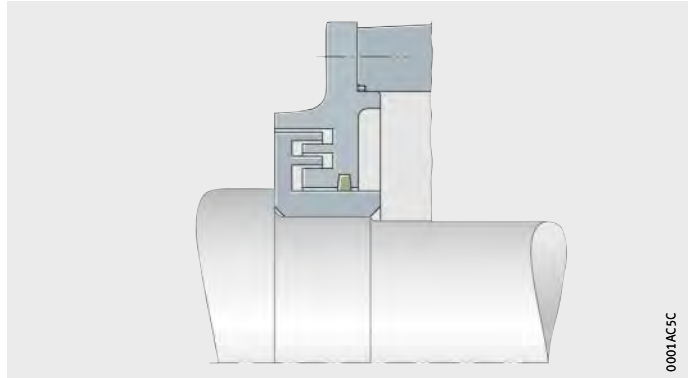

Figure 1
Labyrinth with felt seal
for plummer block housing BNM

Housing configurations

The housing configuration of plummer block housings BNM can be selected as either a continuous shaft or a housing closed on one side. All plummer block housings BNM are provided with grease valves and labyrinth seals, *Figure 2* and *Figure 3*.

- ① Locating bearing BNM...AH-R-AF
- ② Non-locating bearing BNM...AH-R-AL

Figure 2
Plummer block housing BNM for bearings with tapered bore and withdrawal sleeve, design A

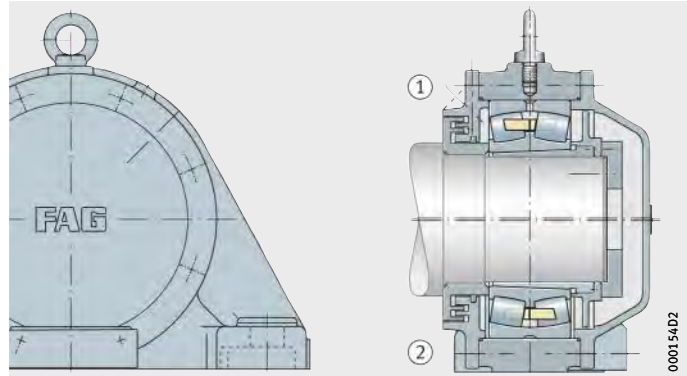

- ① Locating bearing BNM...AH-R-BF
- ② Non-locating bearing BNM...AH-R-BL

Figure 3
Plummer block housing BNM for bearings with tapered bore and withdrawal sleeve, design B

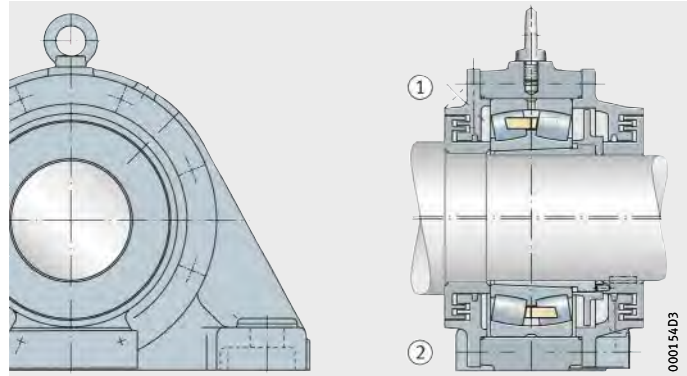

Lubrication

Unsplit plummer block housings BNM are designed for grease lubrication.

The housings have button head lubrication nipples to DIN 3404-M10×1 for relubrication of the bearing and seals. All the threaded holes for the lubrication nipples are located in the covers. The grease for the bearing is introduced into the housing on one side, then enters the bearing and is transported on the other side of the bearing by the grease valve into the grease collector.

Unsplit plummer block housings BNM

Designation structure

The designation structure for split plummer block housings BNM is shown in the table and *Figure 4*.

Designation structure of plummer block housings BNM

Feature	Code	Description
① Series	BNM	Unsplit plummer block housings BNM
② ISO dimension series of bearing	32	ISO dimension series 32
③ Bore code of bearing	52	Bore diameter (52 · 5) mm = 260 mm
④ Bearing bore	AH	Tapered bearing bore and withdrawal sleeve
⑤ Grease valve	R	With grease valve
⑥ Housing design	AF	Closed on one side, locating bearing
	AL	Closed on one side, non-locating bearing
	BF	Continuous shaft, locating bearing
	BL	Continuous shaft, non-locating bearing



Figure 4
Designation structure of plummer block housings BNM, example

Ordering example

When ordering an unsplit plummer block housing BNM, the designation contains indications of the size and location method of the bearing as well as the design and material of the housing. The rolling bearing and, if necessary, the withdrawal sleeve must be ordered separately.

The ordering example shows the construction of an order for a selected housing configuration and the appropriate bearing. The allocation of housings, bearings and withdrawal sleeves for all housing sizes is shown in the dimension table.

Example 1

Plummer block housing BNM, closed on one side, grease valve, spherical roller bearing 23260-K-MB as locating bearing, location using withdrawal sleeve.

Order

1 plummer block housing	BNN3260-AH-R-AF
1 spherical roller bearing	23260-K-MB
1 withdrawal sleeve	AH3260G-H

Design and safety guidelines

Eye bolts

The housing has an eye bolt in accordance with DIN 580. This is intended as a locating point for mounting and dismounting of the housing. The load carrying capacity of the eye bolt only allows lifting of the housing without a bearing.



The eye bolt must always be screwed fully into the housing. The eye bolt must not be subjected to a load that is more than the mass of the housing.

Foot screws

Foot screws are used for screw mounting of the housings to the locating surface. They are not included in the scope of delivery of the housings.

The appropriate screw size for each housing is stated, see dimension table.

The associated tightening torques are stated for screws with a metric thread in accordance with DIN 13, DIN 962 and DIN ISO 965-2, see table, page 42.

Accuracy

The bearing seat in unsplit plummer block housings BNM is machined to the tolerance class H7.

By agreement, the housings can also be supplied with other tolerance classes for the bearing seat, see section Tolerance class of bearing seat, page 47.



Plummer block housings

BNM, unsplit
 For spherical roller bearings with tapered bore and withdrawal sleeve
 Stepped shaft

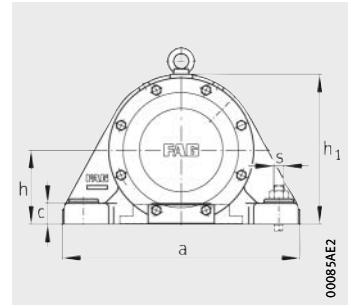
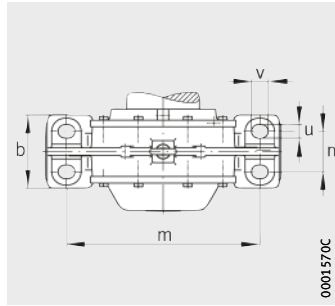

Dimension table - Dimensions in mm

Shaft			Housing Dimensions									
d ₁	d ₂	d _c max.	h	h ₁	b	c	a	m	n	v	u	s
150	155	165	190	385	180	58	600	490	105	45	36	M30
160	165	181	210	405	200	62	640	525	110	45	36	M30
170	175	185	210	425	210	65	680	550	120	45	36	M30
180	185	195	220	455	220	85	710	560	120	52	42	M36
190	195	205	235	475	240	75	780	640	140	52	42	M36
200	210	220	260	525	250	80	850	700	140	52	42	M36
220	230	242	290	585	250	90	900	750	140	52	42	M36
240	250	262	310	625	290	95	960	800	160	52	42	M36
260	270	282	320	645	300	100	1000	840	170	52	42	M36
280	290	302	350	705	330	105	1100	920	180	75	56	M48
300	310	326	370	745	360	115	1150	960	200	75	56	M48
320	330	350	390	790	380	125	1200	990	200	85	64	M56
340	350	370	410	820	400	130	1280	1040	210	90	72	M64
360	370	390	425	860	405	135	1350	1100	225	90	72	M64
380	390	410	450	900	450	145	1430	1160	240	90	72	M64
400	410	430	470	950	470	150	1500	1220	255	90	72	M64

① Locating bearing AF; ② Non-locating bearing AL; ③ Locating bearing BF; ④ Non-locating bearing BL

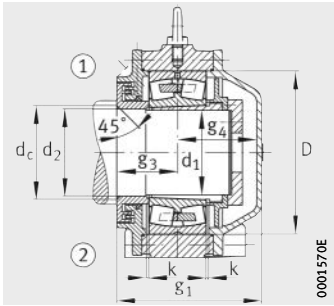

Design A

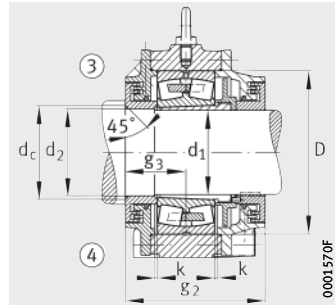

Design B

D	k	g ₁	g ₂	g ₃	g ₄ min.	Bearing	Withdrawal sleeve	Housing	
								Mass m ≈ kg	Designation
290	3	275	275	120	145	23232.-K	AH3232(-H)	100	BNM3232-AH
310	4	275	265	115	150	23234.-K	AH3234(-H)	135	BNM3234-AH
320	4	310	310	135	165	23236.-K	AH3236(-H)	160	BNM3236-AH
340	4	325	330	145	170	23238.-K	AH3238(-H)	180	BNM3238-AH
360	4	350	350	155	185	23240.-K	AH3240(-H)	240	BNM3240-AH
400	4	375	385	165	200	23244.-K	AH2344(-H)	290	BNM3244-AH
440	4	360	365	155	195	23248.-K	AH2348(-H)	330	BNM3248-AH
480	5	415	410	180	220	23252.-K	AH2352(-H)	480	BNM3252-AH
500	5	435	440	190	230	23256.-K	AH2356(-H)	550	BNM3256-AH
540	5	455	450	200	240	23260.-K	AH3260(-H)	660	BNM3260-AH
580	5	490	475	210	265	23264.-K	AH3264-H	800	BNM3264-AH
620	6	515	505	220	280	23268.-K	AH3268-H	930	BNM3268-AH
650	6	545	535	235	295	23272.-K	AH3272-H	1 100	BNM3272-AH
680	6	570	575	255	300	23276.-K	AH3276-H	1 210	BNM3276-AH
720	6	605	605	270	320	23280.-K	AH3280-H	1 510	BNM3280-AH
760	7,5	615	625	280	320	23284.-K	AH3284-H	1 710	BNM3284-AH



FAG



Unsplit plummer block housings BND

Unsplit plummer block housings BND

	Page
Product overview	Unsplit plummer block housings BND 302
Features	Suitable bearings 303
	Housing materials and anti-corrosion protection 303
	Locating and non-locating bearings 304
	Seals and covers 304
	Housing configurations..... 305
	Lubrication 308
	Designation structure 310
	Ordering examples 311
Design and safety guidelines	Load carrying capacity 312
	Eye bolts 315
	Foot screws 315
Accuracy 315
Dimension tables	Plummer block housings BND, unsplit, for spherical roller bearings with tapered bore and adapter sleeve..... 316
	Plummer block housings BND, unsplit, for spherical roller bearings with tapered bore and adapter sleeve, stepped shaft..... 322
	Plummer block housings BND, unsplit, for spherical roller bearings with cylindrical bore..... 328



Product overview Unsplit plummer block housings BND

Plummer block housings

Unsplit

Closed on one side, with cover

BND..-AF, BND..-AL



0001ABA2

For continuous shaft

BND..-BF, BND..-BL



0001ABA4

Unsplit plummer block housings BND

Features Unsplit plummer block housings BND are suitable for very high loads. The housings, which were originally developed for belt conveyors, can also be beneficially used in materials processing, for example in hard crushers, sugar cane mill drives and rotor shafts in wind turbines.

Suitable bearings The dimensions of unsplit plummer block housings BND are matched to spherical roller bearings 222, 230, 231 and 232, see table. The range of shaft diameters is between 60 mm and 420 mm.

Bearing type and sizes

Bearing type	Size
Spherical roller bearings ■ with tapered bore and adapter sleeve	22213..-K to 22284..-K
	23024..-K to 23084..-K
	23122..-K to 23184..-K
	23222..-K to 23284..-K
■ with cylindrical bore	22213 to 22284
	23024 to 23084
	23122 to 23184
	23222 to 23284



Housing materials and anti-corrosion protection

The standard material for the housing bodies is cast steel (suffix S). By agreement, housing bodies made from spheroidal graphite cast iron (suffix D) are available.

All outer surfaces not machined by chip-forming methods have a universal paint coating (colour RAL 7031, bluish-grey). The coating can be finished using all synthetic resin, polyurethane, acrylic, epoxy resin, chlorinated rubber, nitrocellulose and acid-hardening hammer tone finishes.

Inner and outer surfaces machined by chip-forming methods are provided with anti-corrosion protection that can be easily removed. It is recommended that only volatile solvents and lint-free cloths should be used.

Unsplit plummer block housings BND

Locating and non-locating bearings

The housings are supplied as a locating bearing design or non-locating bearing design. In the locating bearing, the bearing is clamped between the housing covers. In the non-locating bearing, the bearing can align itself axially, since the covers have shorter centring collars.

Seals and covers

Plummer block housings BND of design A are intended for the bearing arrangements of shaft ends. One side is closed by a cover and the other side is sealed against the shaft. Design B is intended for continuous shafts, in which case the housing is sealed against the shaft on both sides.

Labyrinth seals (suffix Y) or Taconite seals (suffix T) can be used, *Figure 1*. Where shafts of constant diameter are used, the seals are located on the shaft by means of slotted conical clamping rings made from laminated fabric. The labyrinth rings, Taconite seals and covers are unsplit.

The seals allow shaft misalignment of up to $0,5^\circ$ in both directions and are suitable for grease lubrication.

- ① Labyrinth seal
- ② Taconite seal

Figure 1
Seals
for plummer block housings BND

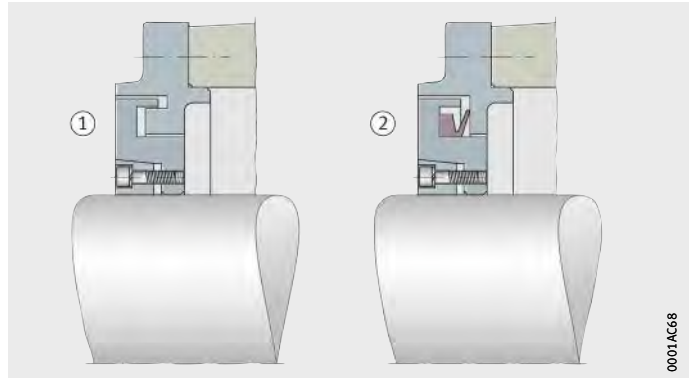

Housing configurations

In the case of plummer block housings BND, various configurations are possible that are clearly described by means of the designation, *Figure 2 to Figure 13*, page 308.

The following features can be varied in the housing configuration:

- location method of the bearing:
 - bearings with a tapered bore by means of an adapter sleeve on a shaft of constant diameter
 - bearings with a tapered bore by means of an adapter sleeve on a stepped shaft
 - bearings with a cylindrical bore directly on a stepped shaft
- sealing of the housing by means of a labyrinth seal or a Taconite seal
- continuous shaft or a housing closed on one side
- design of the bearing arrangement as a locating bearing arrangement or a non-locating bearing arrangement.

- ① Locating bearing BND..-H-W-Y-AF
- ② Non-locating bearing BND..-H-W-Y-AL

Figure 2

Plummer block housing BND for bearings with tapered bore and adapter sleeve (labyrinth seal), design A

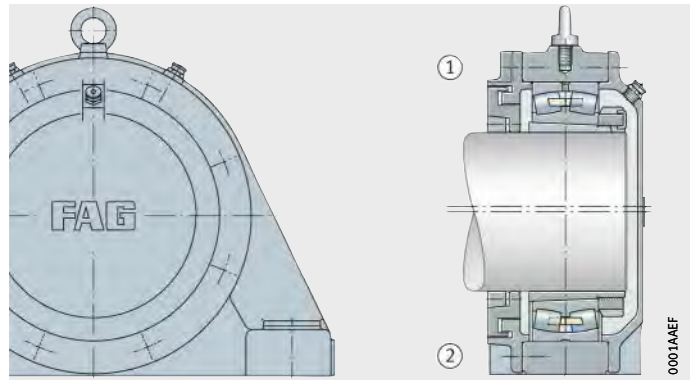

- ① Locating bearing BND..-H-W-Y-BF
- ② Non-locating bearing BND..-H-W-Y-BL

Figure 3

Plummer block housing BND for bearings with tapered bore and adapter sleeve (labyrinth seal), design B

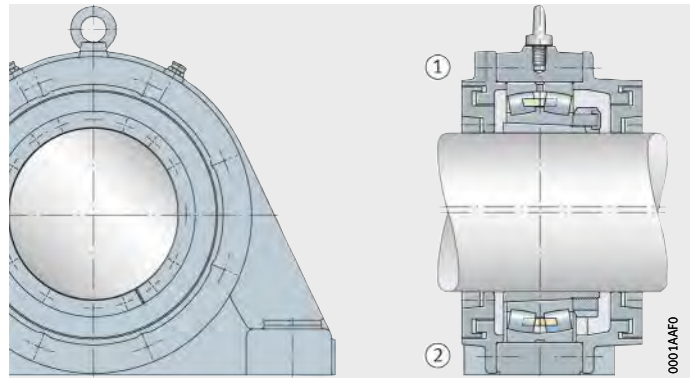

Unsplit plummer block housings BND

- ① Locating bearing BND...H-W-T-AF
- ② Non-locating bearing BND...H-W-T-AL

Figure 4
Plummer block housing BND for bearings with tapered bore and adapter sleeve (Taconite seal), design A

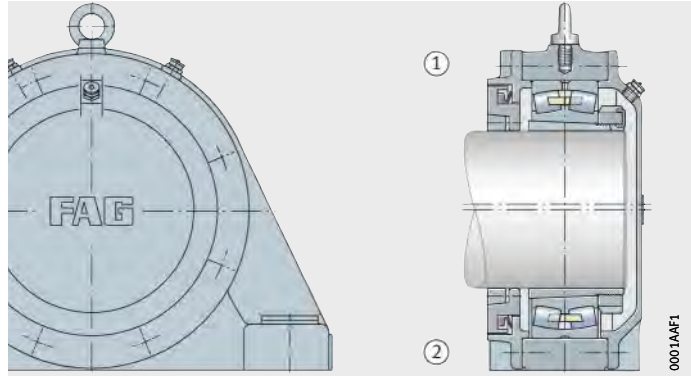

- ① Locating bearing BND...H-W-T-BF
- ② Non-locating bearing BND...H-W-T-BL

Figure 5
Plummer block housing BND for bearings with tapered bore and adapter sleeve (Taconite seal), design B

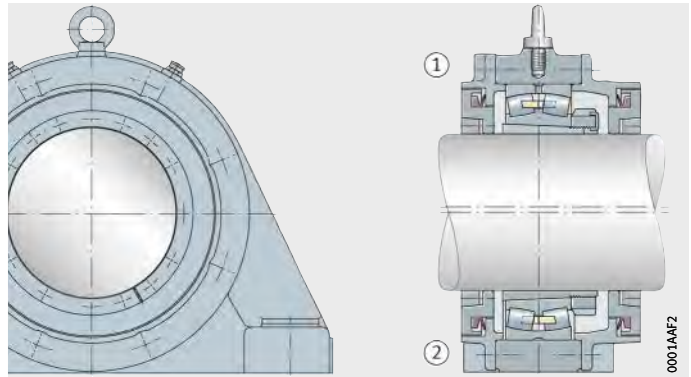

- ① Locating bearing BND...H-C-Y-AF
- ② Non-locating bearing BND...H-C-Y-AL

Figure 6
Plummer block housing BND for bearings with tapered bore and adapter sleeve for stepped shaft (labyrinth seal), design A

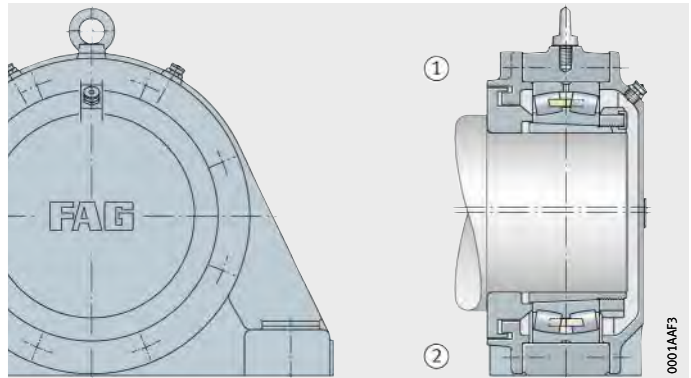

- ① Locating bearing BND...H-C-Y-BF
- ② Non-locating bearing BND...H-C-Y-BL

Figure 7
Plummer block housing BND for bearings with tapered bore and adapter sleeve for stepped shaft (labyrinth seal), design B

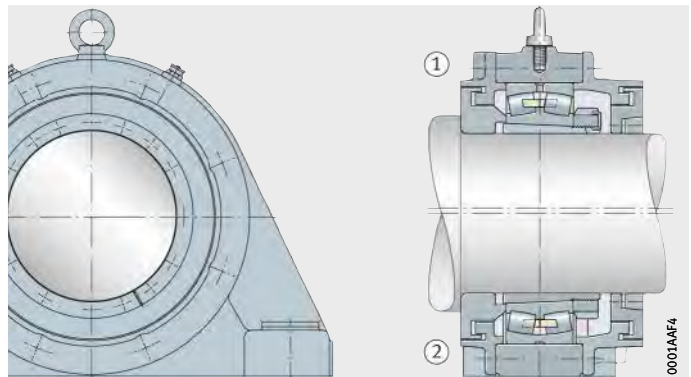

- ① Locating bearing BND...H-C-T-AF
- ② Non-locating bearing BND...H-C-T-AL

Figure 8

Plummer block housing BND for bearings with tapered bore and adapter sleeve for stepped shaft (Taconite seal), design A

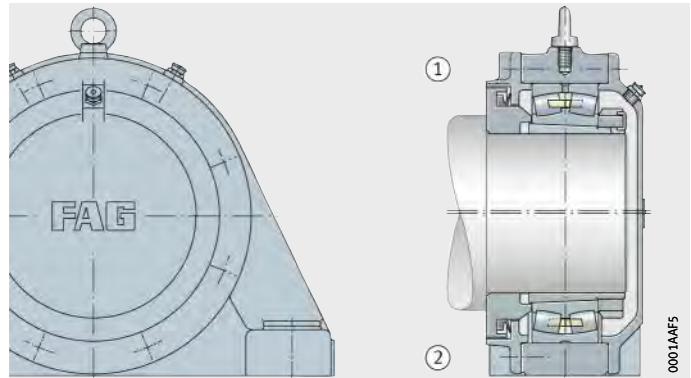

- ① Locating bearing BND...H-C-T-BF
- ② Non-locating bearing BND...H-C-T-BL

Figure 9

Plummer block housing BND for bearings with tapered bore and adapter sleeve for stepped shaft (Taconite seal), design B

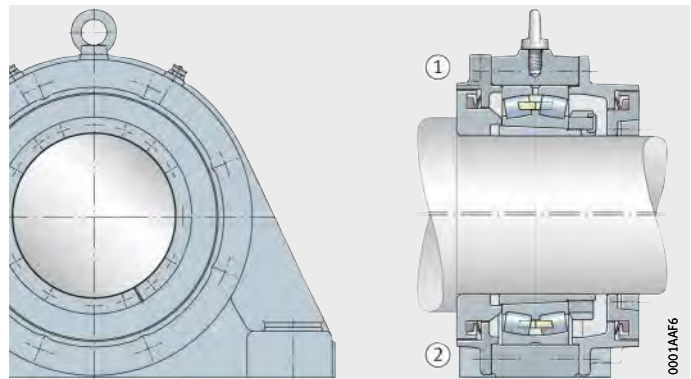

- ① Locating bearing BND...Z-Y-AF
- ② Non-locating bearing BND...Z-Y-AL

Figure 10

Plummer block housing BND for bearings with cylindrical bore (labyrinth seal), design A

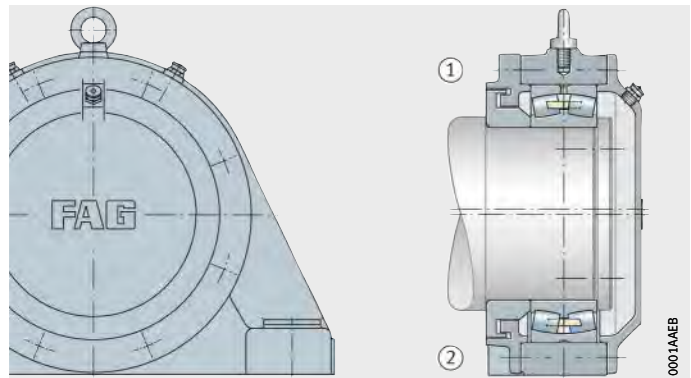

- ① Locating bearing BND...Z-Y-BF
- ② Non-locating bearing BND...Z-Y-BL

Figure 11

Plummer block housing BND for bearings with cylindrical bore (labyrinth seal), design B

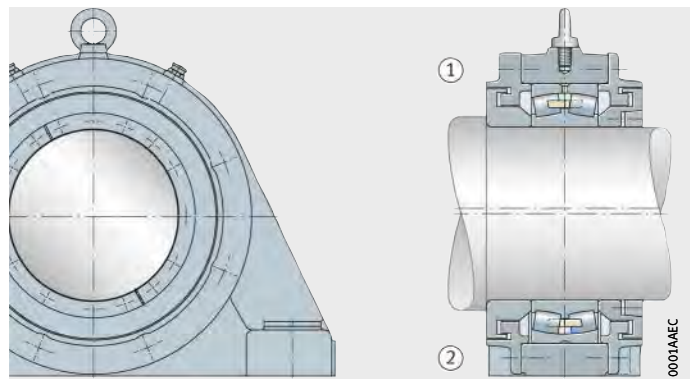

Unsplit plummer block housings BND

- ① Locating bearing BND..-Z-T-AF
- ② Non-locating bearing BND..-Z-T-AL

Figure 12
Plummer block housing BND for bearings with cylindrical bore (Taconite seal), design A

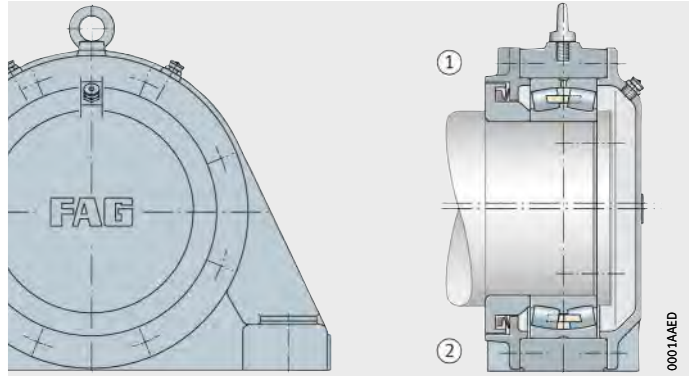

- ① Locating bearing BND..-Z-T-BF
- ② Non-locating bearing BND..-Z-T-BL

Figure 13
Plummer block housing BND for bearings with cylindrical bore (Taconite seal), design B

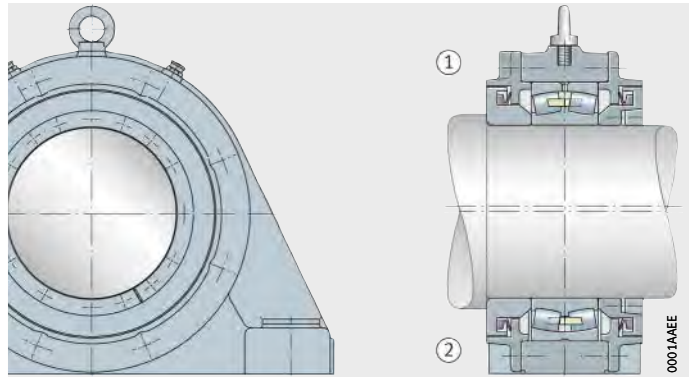

Lubrication

Unsplit plummer block housings BND are designed for grease lubrication.

Greases

Suitable greases are lithium soap greases of NLGI grades 2 and 3, for example Arcanol MULTI3 for low loads and Arcanol MULTITOP and LOAD400 for high and very high loads.

Grease quantities

In initial lubrication, the cavities in the bearing, the housing and the labyrinths are completely filled with grease. This is the basis for the recommended grease quantities, see table, page 309.

For relubrication, it is recommended that the grease quantity is approx. 10% of the grease quantity used in initial greasing. If the ambient conditions lead to heavy contamination of the housings, relubrication should be carried out on a daily basis using smaller quantities.

Recommended grease quantity

Bearing bore mm	Grease quantity for initial greasing	
	BND22, BND31, BND32 ≈ g	BND30 ≈ g
65	700	–
75	800	–
90	900	–
100	950	–
110	1 000	–
120	1 100	500
130	1 250	600
140	1 400	700
150	1 700	800
160	1 900	900
170	2 200	1 000
180	2 500	1 200
190	3 000	1 300
200	3 600	1 600
220	4 200	1 900
240	5 000	2 100
260	6 000	2 500
280	7 000	3 000
300	8 000	3 500
320	9 000	4 100
340	10 500	4 800
360	12 000	5 500
380	13 000	6 200
400	14 500	7 000
420	16 000	8 000



Relubrication

The housings have button head lubrication nipples with a head diameter standardised to DIN 3404 of 22 mm. The grease is fed uniformly to both rows of rollers via the circumferential slot and three lubrication holes in the outer ring of the spherical roller bearings.

The relubrication intervals should be matched to the ambient conditions. The bearings should be relubricated after an interval of no more than 4 weeks.

Unsplit plummer block housings BND

Designation structure

The designation structure for unsplit plummer block housings BND is shown in the table and *Figure 14*.

Designation structure of plummer block housings BND

Feature	Code	Description
① Series	BND	Unsplit plummer block housings BND
② ISO dimension series of bearing	22	ISO dimension series 22
	30	ISO dimension series 30
	31	ISO dimension series 31
	32	ISO dimension series 32
③ Bore code of bearing	52	Bore diameter (52 · 5) mm = 260 mm
④ Bearing bore	H	Tapered bearing bore and adapter sleeve
	Z	Cylindrical bearing bore
⑤ Shaft	W	Shaft of constant diameter (only in conjunction with bearing bore H)
	C	Stepped shaft (only in conjunction with bearing bore H)
⑥ Seal	Y	Labyrinth seal
	T	Taconite seal
⑦ Housing design	AF	Closed on one side, locating bearing
	AL	Closed on one side, non-locating bearing
	BF	Continuous shaft, locating bearing
	BL	Continuous shaft, non-locating bearing
⑧ Housing material	S	Cast steel (standard)
	D	Spheroidal graphite cast iron

Figure 14
Designation structure of plummer block housings BND, example



Ordering examples

When ordering an unsplit plummer block housing BND, the designation contains indications of the size and location method of the bearing, the shaft design, the sealing variant and the design and material of the housing. The rolling bearing and, if necessary, the adapter sleeve must be ordered separately.

The ordering examples show the construction of orders for selected housing combinations and the appropriate bearings. The allocation of housings, bearings and accessories for all housing sizes is shown in the dimension tables.

- Example 1** Plummer block housing BND made from cast steel, closed on one side, for shaft of constant diameter, Taconite seal, spherical roller bearing 23260-K-MB as locating bearing, location using adapter sleeve.
- Order 1 plummer block housing BND3260-H-W-T-AL-S
1 spherical roller bearing 23260-K-MB
1 adapter sleeve H3260-HG
- Example 2** Plummer block housing BND made from cast steel, for continuous stepped shaft, Taconite seal, spherical roller bearing 23084-B-K-MB as locating bearing, location using adapter sleeve.
- Order 1 plummer block housing BND3084-H-C-T-BF-S
1 spherical roller bearing 23084-B-K-MB
1 adapter sleeve H3084X-HG
- Example 3** Plummer block housing BND made from cast steel, closed on one side, labyrinth seal, spherical roller bearing 23148-B-MB as locating bearing.
- Order 1 plummer block housing BND3148-Z-Y-AF-S
1 spherical roller bearing 23148-B-MB



Unsplit plummer block housings BND

Design and safety guidelines

Load carrying capacity

Guide values for the rupture load of plummer block housings BND are given, *Figure 15* and tables, page 313 and page 314. The guide values are valid for purely static loading. They are valid for the standard material cast steel (suffix S) and for spheroidal graphite cast iron (suffix D).

The guide values in the table, page 313, are only valid if the flatness of the mounting surface in accordance with DIN EN ISO 1101 corresponds to the tolerance grade IT7 in accordance with DIN EN ISO 286-1 (measured across the diagonal). A precondition for supporting loads is that the housing base surface is completely and rigidly supported.

When determining the permissible static load, a safety factor of 6 must be applied.



The housing must not be subjected to an axial load of more than 20% of the housing rupture load F_{180° .

If the housing is subjected to axial load, the permissible axial load of the bearing fitted must be taken into consideration. If the bearing is located on the shaft using an adapter sleeve, the axial retaining force of the bearing and adapter sleeve must also be taken into consideration.

If the load direction is between 55° and 120° or axial load is present, we recommend that the housings should be secured in the load direction by means of stops or dowels.

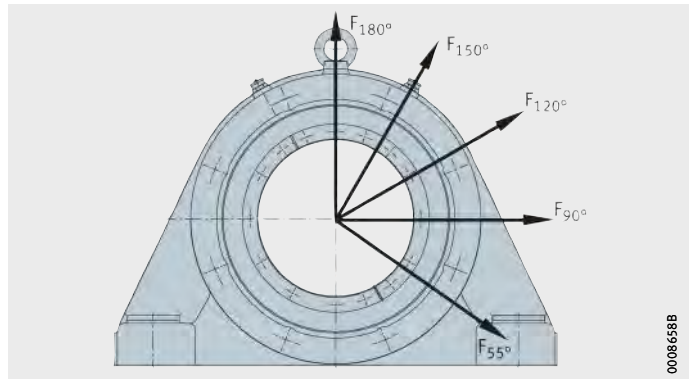

Figure 15
Load directions F
of the guide values
for housing rupture load

Housings BND22 and BND30

Housing Designation		Housing rupture load in load direction F				
		55° kN	90° kN	120° kN	150° kN	180° kN
BND2213	–	665	530	440	350	440
BND2215	–	880	705	580	465	580
BND2218	–	1 125	900	745	595	745
BND2220	BND3024	1 325	1 070	1 020	815	1 020
BND2222	BND3026	1 580	1 275	1 120	920	1 120
BND2224	BND3028	1 785	1 430	1 225	1 020	1 225
BND2226	BND3030	2 040	1 630	2 140	1 735	2 140
–	BND3032	2 295	1 835	2 245	1 835	2 245
BND2228	BND3034	2 755	2 195	2 245	1 835	2 245
BND2230	BND3036	3 060	2 450	2 245	1 835	2 245
BND2232	BND3038	3 365	2 705	2 450	1 940	2 450
BND2234	BND3040	3 925	3 110	3 060	2 450	3 060
BND2236	–	4 435	3 570	3 470	2 755	3 470
BND2238	BND3044	4 435	3 570	3 470	2 755	3 470
BND2240	BND3048	5 050	4 030	4 895	3 875	4 895
BND2244	BND3052	5 660	4 540	5 000	3 980	5 000
–	BND3056	6 580	5 255	6 120	4 895	6 120
BND2248	BND3060	7 295	5 815	6 325	5 100	6 325
BND2252	BND3064	8 000	6 425	6 835	5 400	6 835
BND2256	BND3068	8 825	7 040	6 835	5 400	6 835
BND2260	BND3072	9 640	7 700	8 160	6 530	8 160
–	BND3076	10 810	8 670	8 365	8 770	8 365
BND2264	BND3080	12 035	9 690	9 080	7 240	9 080
BND2268	BND3084	13 360	10 760	9 280	7 345	9 280
BND2272	–	15 700	12 570	10 370	8 325	10 370
BND2276	–	16 600	13 280	10 960	8 800	10 960
BND2280	–	19 750	15 800	13 030	10 470	13 030
BND2284	–	21 540	17 240	14 220	11 420	14 220



Unsplit plumber block housings BND

Housings BND31 and BND32

Housing Designation		Housing rupture load in load direction F				
		55° kN	90° kN	120° kN	150° kN	180° kN
BND3122	–	1 900	1 530	1 685	1 345	1 685
BND3124	BND3222	1 875	1 500	1 685	1 345	1 685
BND3126	BND3224	2 020	1 610	1 735	1 385	1 735
BND3128	BND3226	2 295	1 835	1 735	1 385	1 735
BND3130	BND3228	2 755	2 195	1 785	1 430	1 785
BND3132	BND3230	3 110	2 500	1 835	1 470	1 835
BND3134	BND3232	3 570	2 855	1 940	1 550	1 940
BND3136	BND3234	4 285	3 415	2 040	1 630	2 040
BND3138	BND3236	4 590	3 725	2 140	1 715	2 140
BND3140	BND3238	5 610	4 540	2 295	1 835	2 295
BND3144	BND3240	6 120	4 935	2 550	2 040	2 550
BND3148	BND3244	6 835	5 510	3 060	2 450	3 060
BND3152	BND3248	7 650	6 170	3 570	2 855	3 570
BND3156	BND3252	9 385	7 550	4 180	3 365	4 180
BND3160	BND3256	10 200	8 260	4 490	3 570	4 490
BND3164	BND3260	11 935	9 535	5 100	4 080	5 100
BND3168	BND3264	14 280	11 375	5 815	4 590	5 815
BND3172	–	14 485	11 630	6 630	5 300	6 630
BND3176	BND3268	16 320	13 055	6 630	5 300	6 630
BND3180	BND3272	17 850	14 280	7 345	5 815	7 345
–	BND3276	18 870	15 050	8 160	6 530	8 160
BND3184	–	19 380	15 600	8 160	6 530	8 160
–	BND3280	22 440	17 950	9 280	7 445	9 280
–	BND3284	24 480	19 380	10 710	8 570	10 710

Eye bolts The housing has an eye bolt in accordance with DIN 580. This is intended as a locating point for mounting and dismounting of the housing. The load carrying capacity of the eye bolt allows lifting of the housing including a bearing fitted in the housing.



The eye bolt must always be screwed fully into the housing.
The eye bolt must not be subjected to a mass greater than that of the housing together with the bearing fitted in the housing.

Foot screws Foot screws are used for screw mounting of the housings to the locating surface. They are not included in the scope of delivery of the housings.

The appropriate screw size for each housing is stated, see dimension tables.

The associated tightening torques are stated for screws with a metric thread in accordance with DIN 13, DIN 962 and DIN ISO 965-2, see table, page 42.

Accuracy The bearing seat in unsplit plummer block housings BND is machined to the tolerance class H7.
By agreement, the housings can also be supplied with other tolerance classes for the bearing seat, see section Tolerance class of bearing seat, page 47.



Plummer block housings

BND, unsplit
For spherical roller bearings with tapered bore and adapter sleeve

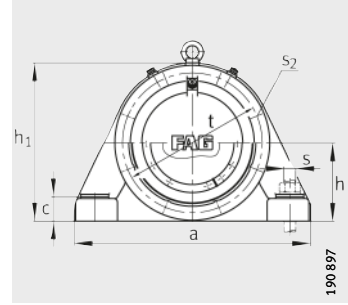
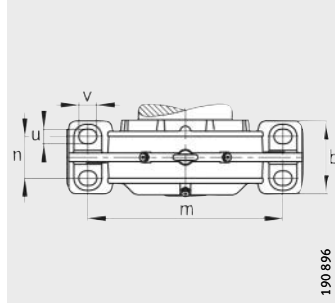

Dimension table - Dimensions in mm

Shaft d_1	Housing Dimensions												
	h	h_1	g	b	c	a	m	n	v	u	s	D	k
60	80	155	44	70	22	235	185	40	20	15	M10	120	2
65	90	180	45	85	35	285	225	45	28	20	M16	130	2
80	110	220	55	110	38	370	290	60	32	23	M20	160	2
90	130	255	65	120	40	400	320	65	35	30	M24	180	2,5
100	140	280	73	130	42	440	350	70	35	30	M24	200	2,5
100	130	263	80	140	40	400	300	80	35	25	M20	180	2,5
100	140	280	89,8	130	42	440	350	70	35	30	M24	200	2,5
110	150	300	77	140	42	470	370	75	35	30	M24	215	2,5
110	115	230	60	110	35	370	300	60	35	25	M20	180	2,5
110	140	280	85	150	40	410	330	80	35	25	M20	200	2,5
110	150	300	95	140	42	470	370	75	35	30	M24	215	2,5
115	160	315	84	150	45	500	400	85	35	30	M24	230	3
115	130	260	70	120	38	410	340	60	35	25	M20	200	2
115	145	295	90	150	40	430	350	80	35	25	M20	210	3
115	160	315	100	150	45	500	400	85	35	30	M24	230	3
125	170	345	88	160	50	530	430	85	35	30	M24	250	3
125	140	275	70	130	40	430	360	70	35	30	M24	210	3
125	155	315	95	160	45	470	380	85	35	25	M20	225	3
125	170	345	108	160	50	530	430	85	35	30	M24	250	3
135	180	365	97	170	54	550	450	90	45	36	M30	270	3
135	145	290	80	140	42	455	370	80	35	30	M24	225	2
135	170	345	102	200	60	580	450	110	35	30	M24	250	2
135	180	365	120	170	54	550	450	90	45	36	M30	270	3
140	190	385	106	180	58	600	490	105	45	36	M30	290	3
140	155	310	85	150	45	480	390	90	35	30	M24	240	3
140	180	360	110	200	55	540	430	110	35	30	M24	270	3
140	190	385	130	180	58	600	490	105	45	36	M30	290	3
150	200	405	111	200	62	640	525	110	45	36	M30	310	3
150	165	330	90	160	50	510	420	95	45	36	M30	260	2
150	190	380	120	200	55	570	470	110	45	36	M30	280	3
150	200	405	135	200	62	640	525	110	45	36	M30	310	3

① Locating bearing AF; ② Non-locating bearing AL; ③ Locating bearing BF; ④ Non-locating bearing BL

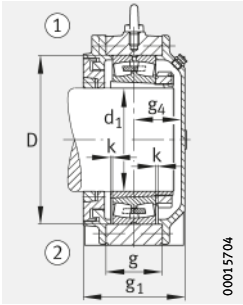

Design A
Housing with labyrinth seal

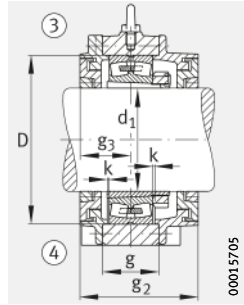

Design B

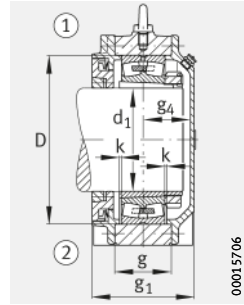

Design A
Housing with Taconite seal

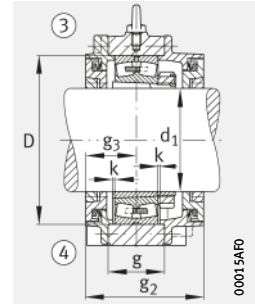

Design B

						Spherical roller bearing and accessories		Housing		
g ₁	g ₂	g ₃	g ₄ min.	t	s ₂	Quantity	Bearing	Adapter sleeve	Mass m ≈ kg	Designation
105	125	55	44	155	M6	6	22215..-K	H315	15	BND2215-H-W...S
104	123	53	45	185	M8	6	22218..-K	H318	28	BND2218-H-W...S
141	168	78	57	205	M8	6	22220..-K	H320	30	BND2220-H-W...S
149,2	172	82,6	60	230	M12	6	22222..-K	H322	50	BND2222-H-W...S
146	171	78	62	215	M12	8	23122..-K	H3122	40	BND3122-H-W...S
166	194	91	68	230	M12	6	23222..-K	H2322	35	BND3222-H-W...S
143	168	74	61	245	M12	6	22224..-K	H3124	58	BND2224-H-W...S
126	146	63	57	205	M8	8	23024..-K	H3024	20	BND3024-H-W...S
160	180	80	74	235	M12	8	23124..-K	H3124	50	BND3124-H-W...S
161	186	83	70	245	M12	6	23224..-K	H2324	40	BND3224-H-W...S
172	202	95	69	260	M12	6	22226..-K	H3126	65	BND2226-H-W...S
133	156	68	59	225	M10	8	23026..-K	H3026	30	BND3026-H-W...S
165	190	85	72	245	M12	8	23126..-K	H3126	55	BND3126-H-W...S
188	218	103	77	260	M12	6	23226..-K	H2326	50	BND3226-H-W...S
166	196	88	70	285	M16	6	22228..-K	H3128	70	BND2228-H-W...S
136	156	68	61	240	M10	8	23028..-K	H3028	35	BND3028-H-W...S
170	190	85	77	270	M12	8	23128..-K	H3128	60	BND3128-H-W...S
186	216	98	80	285	M16	6	23228..-K	H2328	65	BND3228-H-W...S
177	202	93,5	76	305	M16	6	22230..-K	H3130	85	BND2230-H-W...S
149	176	78	64	250	M12	8	23030..-K	H3030	40	BND3030-H-W...S
186	206	93	85	285	M12	8	23130..-K	H3130	70	BND3130-H-W...S
200	225	105	87	305	M16	6	23230..-K	H2330	75	BND3230-H-W...S
189	226	103	78	330	M16	6	22232..-K	H3132(-HG)	100	BND2232-H-W...S
156	181	78	71	265	M12	8	23032..-K	H3032(-HG)	45	BND3032-H-W...S
200	230	105	87	310	M16	6	23132..-K	H3132(-HG)	80	BND3132-H-W...S
213	250	115	90	330	M16	6	23232..-K	H2332(-HG)	90	BND3232-H-W...S
216	256	118	88	350	M16	8	22234..-K	H3134(-HG)	105	BND2234-H-W...S
166	191	83	75	285	M12	8	23034..-K	H3034(-HG)	70	BND3034-H-W...S
215	250	115	90	330	M12	8	23134..-K	H3134(-HG)	100	BND3134-H-W...S
240	280	130	100	350	M16	8	23234..-K	H2334(-HG)	120	BND3234-H-W...S



Plummer block housings

BND, unsplit
For spherical roller bearings with tapered bore and adapter sleeve

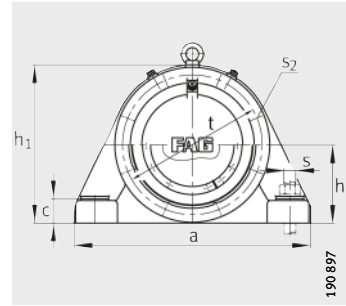
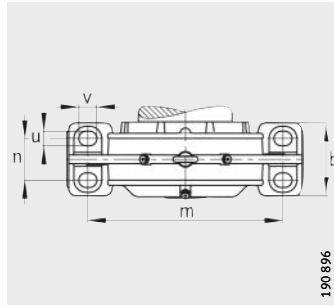

Dimension table (continued) · Dimensions in mm

Shaft d ₁	Housing Dimensions												
	h	h ₁	g	b	c	a	m	n	v	u	s	D	k
160	210	425	112	210	65	680	550	120	45	36	M30	320	3
160	180	360	100	170	52	540	450	100	45	36	M30	280	3
160	200	395	125	200	58	600	490	105	45	36	M30	300	3
160	210	425	138	210	65	680	550	120	45	36	M30	320	3
170	220	455	115	220	85	710	560	120	52	42	M36	340	3
170	185	370	105	180	55	570	480	105	45	36	M30	290	3
170	210	425	130	210	65	680	550	120	45	36	M30	320	3
170	220	455	143	220	85	710	560	120	52	42	M36	340	3
180	235	475	128	240	75	780	640	140	52	42	M36	360	4
180	200	400	110	190	60	600	510	110	45	36	M30	310	3
180	220	455	135	220	85	710	560	120	52	42	M36	340	3
180	235	475	158	240	75	780	640	140	52	42	M36	360	4
200	270	550	140	250	80	890	720	140	52	42	M36	400	4
200	215	430	115	200	65	640	540	115	52	42	M36	340	3
200	235	475	150	240	75	780	640	140	52	42	M36	370	4
200	260	525	175	250	80	850	700	140	52	42	M36	400	4
220	290	585	150	250	90	900	750	140	52	42	M36	440	4
220	225	455	120	210	70	680	560	120	52	42	M36	360	4
220	270	550	160	250	80	890	720	140	52	42	M36	400	4
220	290	585	190	250	90	900	750	140	52	42	M36	440	4
240	310	625	161	290	95	960	800	160	52	42	M36	480	3
240	250	500	130	220	75	720	600	130	52	42	M36	400	4
240	290	585	174	250	90	900	750	140	52	42	M36	440	4
240	310	625	205	290	95	960	800	160	52	42	M36	480	3
260	320	645	160	300	100	1000	840	170	52	42	M36	500	4
260	260	520	135	240	80	760	630	140	52	42	M36	420	4
260	290	585	176	250	90	900	750	140	52	42	M36	460	4
260	320	645	206	300	100	1000	840	170	52	42	M36	500	4

① Locating bearing AF; ② Non-locating bearing AL; ③ Locating bearing BF; ④ Non-locating bearing BL

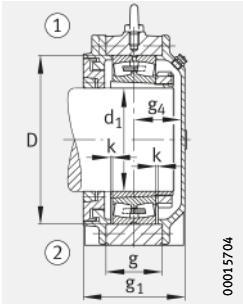

Design A
Housing with labyrinth seal

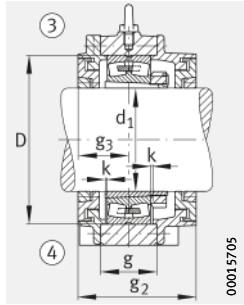

Design B

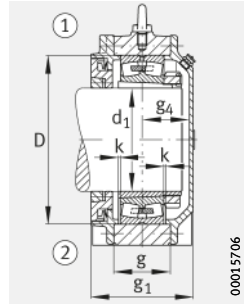

Design A
Housing with Taconite seal

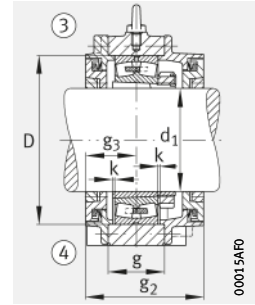

Design B

							Spherical roller bearing and accessories		Housing	
g ₁	g ₂	g ₃	g ₄ min.	t	S ₂		Bearing	Adapter sleeve	Mass m ≈ kg	Designation
						Quantity				
214	248	114	92	370	M16	8	22236..-K	H3136(-HG)	130	BND2236-H-W..-S
176	201	88	80	310	M12	8	23036..-K	H3036(-HG)	70	BND3036-H-W..-S
220	250	115	95	350	M16	8	23136..-K	H3136(-HG)	110	BND3136-H-W..-S
240	274	127	105	370	M16	8	23236..-K	H2336(-HG)	140	BND3236-H-W..-S
222	258	114	98	380	M16	8	22238..-K	H3138(-HG)	170	BND2238-H-W..-S
181	211	93	80	325	M12	8	23038..-K	H3038(-HG)	80	BND3038-H-W..-S
232	266	123	98	370	M16	8	23138..-K	H3138(-HG)	125	BND3138-H-W..-S
250	286	128	112	380	M16	8	23228..-K	H2338(-HG)	170	BND3238-H-W..-S
230	269	123	99	420	M16	8	22240..-K	H3140(-HG)	185	BND2240-H-W..-S
196	226	98	90	340	M16	8	23040..-K	H3040(-HG)	95	BND3040-H-W..-S
242	278	124	108	380	M16	8	23140..-K	H3140(-HG)	170	BND3140-H-W..-S
260	299	138	114	420	M16	8	23240..-K	H2340(-HG)	205	BND3240-H-W..-S
264	314	142	112	455	M20	8	22244..-K	H3144X(-HG)	290	BND2244-H-W..-S
206	241	103	95	375	M16	8	23044..-K	H3044X(-HG)	100	BND3044-H-W..-S
252	291	134	110	420	M16	8	23144..-K	H3144X(-HG)	190	BND3144-H-W..-S
279	329	147	122	445	M20	8	23244..-K	H2344X(-HG)	240	BND3244-H-W..-S
268	311	138	120	510	M20	8	22248..-K	H3148X(-HG)	315	BND2248-H-W..-S
216	251	108	100	400	M16	8	23048..-K	H3048(-HG)	130	BND3048-H-W..-S
284	334	152	122	455	M20	8	23148..-K	H3148X(-HG)	280	BND3148-H-W..-S
308	351	158	140	510	M20	8	23248..-K	H2348X(-HG)	330	BND3248-H-W..-S
286	326	148	126	535	M20	8	22252..-K	H3152X(-HG)	370	BND2252-H-W..-S
226	261	113	103	440	M16	8	23052..-K	H3052X(-HG)	160	BND3052-H-W..-S
292	335	150	132	510	M20	8	23152..-K	H3152X(-HG)	310	BND3152-H-W..-S
330	370	170	148	535	M20	8	23252..-K	H2352X(-HG)	380	BND3252-H-W..-S
297	354	157	128	555	M24	8	22256..-K	H3156X(-HG)	420	BND2256-H-W..-S
236	281	118	108	460	M16	8	23056..-K	H3056(-HG)	180	BND3056-H-W..-S
294	337	151	133	510	M20	8	23156..-K	H3156X(-HG)	335	BND3156-H-W..-S
343	400	180	151	555	M24	8	23256..-K	H2356X(-HG)	490	BND3256-H-W..-S



Plummer block housings

BND, unsplit
For spherical roller bearings with tapered bore and adapter sleeve

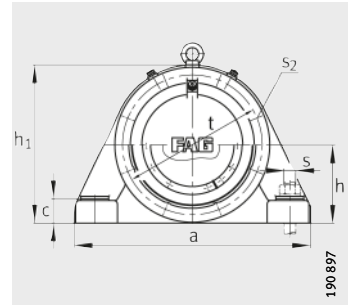
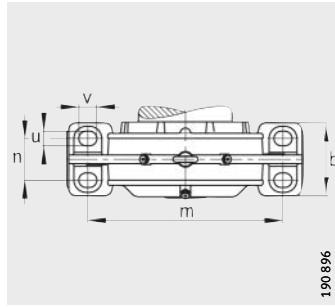

Dimension table (continued) · Dimensions in mm

Shaft d_1	Housing Dimensions												
	h	h_1	g	b	c	a	m	n	v	u	s	D	k
280	350	695	178	330	105	1 100	920	180	75	56	M48	540	4
280	285	570	140	250	85	820	690	150	52	42	M36	460	4
280	320	645	190	300	100	1 000	840	170	52	42	M36	500	4
280	350	705	230	330	105	1 100	920	180	75	56	M48	540	4
300	370	745	180	360	115	1 150	960	200	75	56	M48	580	5
300	295	590	150	260	90	860	730	160	52	42	M36	480	4
300	350	700	210	300	100	1 150	940	160	52	42	M36	540	4
300	370	745	238	360	115	1 150	960	200	75	56	M48	580	5
320	390	790	201	380	125	1 200	990	200	85	64	M56	620	5
320	315	630	160	270	95	900	770	170	52	42	M36	520	5
320	370	745	220	360	115	1 150	960	200	75	56	M48	580	5
320	390	790	260	380	125	1 200	990	200	85	64	M56	620	5
340	410	820	205	400	130	1 280	1 040	210	90	72	M64	650	5
340	330	660	170	280	100	960	820	180	52	42	M36	540	5
340	380	760	225	370	115	1 200	1 000	200	75	56	M48	600	4
340	410	820	267	400	130	1 280	1 040	210	90	72	M64	650	5
360	425	865	230	405	135	1 350	1 100	225	90	72	M64	680	5
360	340	680	160	300	105	1 000	840	190	75	56	M48	560	7
360	390	790	230	380	125	1 200	1 000	200	85	64	M56	620	5
360	425	860	295	405	135	1 350	1 100	225	90	72	M64	680	5
380	450	900	229	450	145	1 430	1 160	240	90	72	M64	720	5
380	360	720	175	320	110	1 060	900	200	75	56	M48	600	7
380	410	820	235	400	130	1 280	1 040	210	90	72	M64	650	5
380	450	900	300	450	145	1 430	1 160	240	90	72	M64	720	5
400	470	950	238	470	150	1 500	1 220	255	90	72	M64	760	5
400	375	755	180	340	115	1 100	940	210	75	56	M48	620	7
400	450	900	260	420	135	1 350	1 100	210	85	64	M56	700	7
400	470	950	315	470	150	1 500	1 220	255	90	72	M64	760	5

① Locating bearing AF; ② Non-locating bearing AL; ③ Locating bearing BF; ④ Non-locating bearing BL

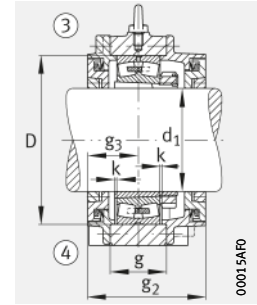
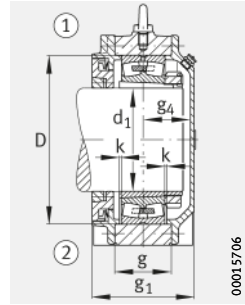
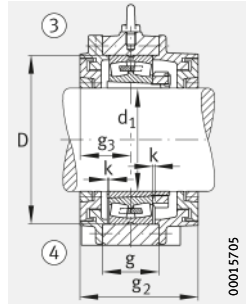
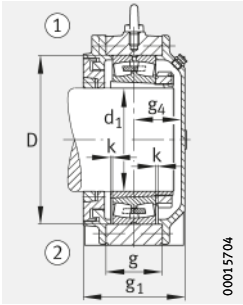

Design A
Housing with labyrinth seal

Design B

Design A
Housing with Taconite seal

Design B

							Spherical roller bearing and accessories		Housing	
g ₁	g ₂	g ₃	g ₄ min.	t	S ₂		Bearing	Adapter sleeve	Mass m ≈ kg	Designation
						Quantity				
317	156	352	149	600	M24	8	22260...K	H3160(-HG)	485	BND2260-H-W...S
261	128	296	121	510	M16	8	23060...K	H3060(-HG)	220	BND3060-H-W...S
327	172	384	143	555	M24	8	23160...K	H3160(-HG)	400	BND3160-H-W...S
369	182	404	175	600	M24	8	23260...K	H3260(-HG)	570	BND3260-H-W...S
333	163	381	158	640	M24	8	22264...K	H3164-HG	600	BND2264-H-W...S
266	133	311	123	530	M16	8	23064...K	H3064-HG	250	BND3064-H-W...S
359	186	412	161	590	M24	8	23164...K	H3164-HG	500	BND3164-H-W...S
391	192	439	187	640	M24	8	23264...K	H3264-HG	665	BND3264-H-W...S
375	187,5	430	176	680	M30	8	22268...K	H3168-HG	635	BND2268-H-W...S
276	133	311	132	565	M20	8	23068...K	H3068-HG	300	BND3068-H-W...S
373	183	421	178	640	M24	8	23168...K	H3168-HG	520	BND3168-H-W...S
434	217	489	205	680	M30	8	23268...K	H3268-HG	755	BND3268-H-W...S
375	185	435	178	710	M30	8	22272...K	H3172-HG	690	BND2272-H-W...S
290	140	325	138	590	M20	8	23072...K	H3072-HG	330	BND3072-H-W...S
400	200	450	188	650	M24	8	23172...K	H3172-HG	600	BND3172-H-W...S
437	216	497	209	710	M30	8	23272...K	H3272-HG	950	BND3272-H-W...S
433	203	470	218	745	M30	8	22276...K	H3176-HG	900	BND2276-H-W...S
294	142	329	141	610	M20	8	23076...K	H3076-HG	360	BND3076-H-W...S
404	202	459	190	680	M30	8	23176...K	H3176-HG	720	BND3176-H-W...S
489	232	529	244	745	M30	8	23276...K	H3276-HG	1 100	BND3276-H-W...S
433	216,5	498	202	790	M30	8	22280...K	H3180-HG	940	BND2280-H-W...S
310	150	355	145	650	M20	8	23080...K	H3080-HG	400	BND3080-H-W...S
405	200	465	193	710	M30	8	23180...K	H3180-HG	750	BND3180-H-W...S
504	252	569	237	790	M30	8	23280...K	H3280-HG	1 205	BND3280-H-W...S
433	216,5	498	202	835	M30	8	22284...K	H3184-HG	1 055	BND2284-H-W...S
310	150	350	149	670	M20	8	23084...K	H3084X-HG	435	BND3084-H-W...S
440	210	510	215	760	M30	8	23184...K	H3184-HG	950	BND3184-H-W...S
510	255	575	240	835	M30	8	23284...K	H3284-HG	1 310	BND3284-H-W...S



Plummer block housings

BND, unsplit
 For spherical roller bearings with tapered bore and adapter sleeve
 Stepped shaft

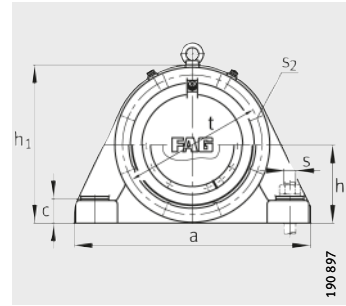
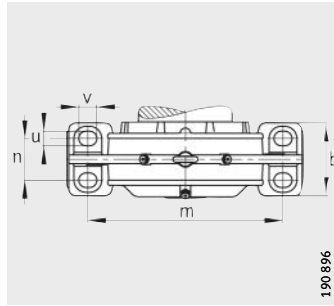

Dimension table - Dimensions in mm

Shaft		Housing Dimensions											
d ₁	d _c max.	h	h ₁	g	b	c	a	m	n	v	u	s	D
60	66	80	155	44	70	22	235	185	40	20	15	M10	120
65	71	90	180	45	85	35	285	225	45	28	20	M16	130
80	88	110	220	55	110	38	370	290	60	32	23	M20	160
90	98	130	255	65	120	40	400	320	65	35	30	M24	180
100	108	140	280	73	130	42	440	350	70	35	30	M24	200
100	108	130	263	80	140	40	400	300	80	35	25	M20	180
100	108	140	280	89,8	130	42	440	350	70	35	30	M24	200
110	118	150	300	77	140	42	470	370	75	35	30	M24	215
110	118	115	230	60	110	35	370	300	60	35	25	M20	180
110	118	140	280	85	150	40	410	330	80	35	25	M20	200
110	118	150	300	95	140	42	470	370	75	35	30	M24	215
115	127	160	315	84	150	45	500	400	85	35	30	M24	230
115	123	130	260	70	120	38	410	340	60	35	25	M20	200
115	123	145	295	90	150	40	430	350	80	35	25	M20	210
115	127	160	315	100	150	45	500	400	85	35	30	M24	230
125	137	170	345	88	160	50	530	430	85	35	30	M24	250
125	133	140	275	70	130	40	430	360	70	35	30	M24	210
125	133	155	315	95	160	45	470	380	85	35	25	M20	225
125	137	170	345	108	160	50	530	430	85	35	30	M24	250
135	147	180	365	97	170	54	550	450	90	45	36	M30	270
135	143	145	290	80	140	42	455	370	80	35	30	M24	225
135	143	170	345	102	200	60	580	450	110	35	30	M24	250
135	147	180	365	120	170	54	550	450	90	45	36	M30	270
140	152	190	385	106	180	58	600	490	105	45	36	M30	290
140	148	155	310	85	150	45	480	390	90	35	30	M24	240
140	148	180	360	110	200	55	540	430	110	35	30	M24	270
140	152	190	385	130	180	58	600	490	105	45	36	M30	290
150	166	200	405	111	200	62	640	525	110	45	36	M30	310
150	158	165	330	90	160	50	510	420	95	45	36	M30	260
150	158	190	380	120	200	55	570	470	110	45	36	M30	280
150	166	200	405	135	200	62	640	525	110	45	36	M30	310

① Locating bearing AF; ② Non-locating bearing AL; ③ Locating bearing BF; ④ Non-locating bearing BL

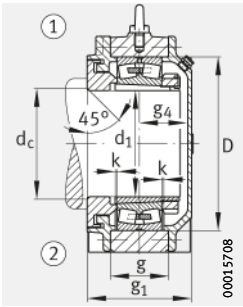

Design A
Housing with labyrinth seal

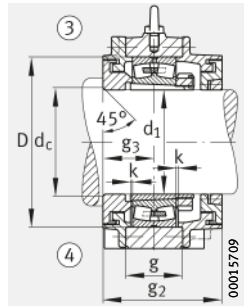

Design B

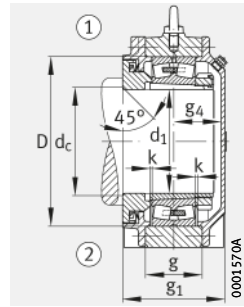

Design A
Housing with Taconite seal

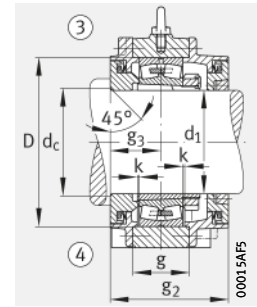

Design B

								Spherical roller bearing and accessories		Housing	
k	g ₁	g ₂	g ₃	g ₄ min.	t	s ₂	Quantity	Bearing	Adapter sleeve	Mass m ≈ kg	Designation
2	105	125	55	44	155	M6	6	22215..-K	H315	15	BND2215-H-C..-S
2	104	123	53	45	185	M8	6	22218..-K	H318	28	BND2218-H-C..-S
2,5	141	168	78	57	205	M8	6	22220..-K	H320	30	BND2220-H-C..-S
2,5	149,2	172	82,6	60	230	M12	6	22222..-K	H322	50	BND2222-H-C..-S
2,5	146	171	78	62	215	M12	8	23122..-K	H3122	40	BND3122-H-C..-S
2,5	166	194	91	68	230	M12	6	23222..-K	H2322	35	BND3222-H-C..-S
2,5	143	168	74	61	245	M12	6	22224..-K	H3124	58	BND2224-H-C..-S
2,5	126	146	63	57	205	M8	8	23024..-K	H3024	20	BND3024-H-C..-S
2,5	160	180	80	74	235	M12	8	23124..-K	H3124	50	BND3124-H-C..-S
2,5	161	186	83	70	245	M12	6	23224..-K	H2324	40	BND3224-H-C..-S
3	172	202	95	69	260	M12	6	22226..-K	H3126	65	BND2226-H-C..-S
2	133	156	68	59	225	M10	8	23026..-K	H3026	30	BND3026-H-C..-S
3	165	190	85	72	245	M12	8	23126..-K	H3126	55	BND3126-H-C..-S
3	188	218	103	77	260	M12	6	23226..-K	H2326	50	BND3226-H-C..-S
3	166	196	88	70	285	M16	6	22228..-K	H3128	70	BND2228-H-C..-S
3	136	156	68	61	240	M10	8	23028..-K	H3028	35	BND3028-H-C..-S
3	170	190	85	77	270	M12	8	23128..-K	H3128	60	BND3128-H-C..-S
3	186	216	98	80	285	M16	6	23228..-K	H2328	65	BND3228-H-C..-S
3	177	202	93,5	76	305	M16	6	22230..-K	H3130	85	BND2230-H-C..-S
2	149	176	78	64	250	M12	8	23030..-K	H3030	40	BND3030-H-C..-S
2	186	206	93	85	285	M12	8	23130..-K	H3130	70	BND3130-H-C..-S
3	200	225	105	87	305	M16	6	23230..-K	H2330	75	BND3230-H-C..-S
3	189	226	103	78	330	M16	6	22232..-K	H3132(-HG)	100	BND2232-H-C..-S
3	156	181	78	71	265	M12	8	23032..-K	H3032(-HG)	45	BND3032-H-C..-S
3	200	230	105	87	310	M16	6	23132..-K	H3132(-HG)	80	BND3132-H-C..-S
3	213	250	115	90	330	M16	6	23232..-K	H2332(-HG)	90	BND3232-H-C..-S
3	216	256	118	88	350	M16	8	22234..-K	H3134(-HG)	105	BND2234-H-C..-S
2	166	191	83	75	285	M12	8	23034..-K	H3034(-HG)	70	BND3034-H-C..-S
3	215	250	115	90	330	M12	8	23134..-K	H3134(-HG)	100	BND3134-H-C..-S
3	240	280	130	100	350	M16	8	23234..-K	H2334(-HG)	120	BND3234-H-C..-S



Plummer block housings

BND, unsplit
 For spherical roller bearings with tapered bore and adapter sleeve
 Stepped shaft

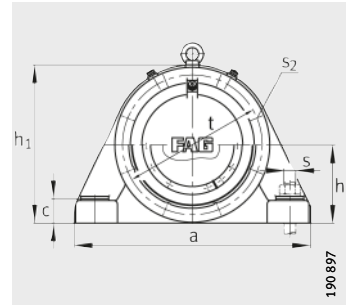
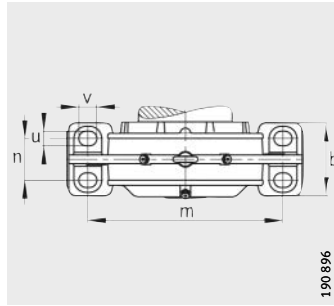

Dimension table (continued) · Dimensions in mm

Shaft		Housing Dimensions											
d ₁	d _c max.	h	h ₁	g	b	c	a	m	n	v	u	s	D
160	176	210	425	112	210	65	680	550	120	45	36	M30	320
160	168	180	360	100	170	52	540	450	100	45	36	M30	280
160	172	200	395	125	200	58	600	490	105	45	36	M30	300
160	176	210	425	138	210	65	680	550	120	45	36	M30	320
170	186	220	455	115	220	85	710	560	120	52	42	M36	340
170	178	185	370	105	180	55	570	480	105	45	36	M30	290
170	182	210	425	130	210	65	680	550	120	45	36	M30	320
170	186	220	455	143	220	85	710	560	120	52	42	M36	340
180	196	235	475	128	240	75	780	640	140	52	42	M36	360
180	188	200	400	110	190	60	600	510	110	45	36	M30	310
180	192	220	455	135	220	85	710	560	120	52	42	M36	340
180	196	235	475	158	240	75	780	640	140	52	42	M36	360
200	216	270	550	140	250	80	890	720	140	52	42	M36	400
200	212	215	430	115	200	65	640	540	115	52	42	M36	340
200	216	235	475	150	240	75	780	640	140	52	42	M36	370
200	216	260	525	175	250	80	850	700	140	52	42	M36	400
220	236	290	585	150	250	90	900	750	140	52	42	M36	440
220	232	225	455	120	210	70	680	560	120	52	42	M36	360
220	236	270	550	160	250	80	890	720	140	52	42	M36	400
220	236	290	585	190	250	90	900	750	140	52	42	M36	440
240	260	310	625	161	290	95	960	800	160	52	42	M36	480
240	256	250	500	130	220	75	720	600	130	52	42	M36	400
240	256	290	585	174	250	90	900	750	140	52	42	M36	440
240	260	310	625	205	290	95	960	800	160	52	42	M36	480
260	280	320	645	160	300	100	1000	840	170	52	42	M36	500
260	276	260	520	135	240	80	760	630	140	52	42	M36	420
260	280	290	585	176	250	90	900	750	140	52	42	M36	460
260	280	320	645	206	300	100	1000	840	170	52	42	M36	500

① Locating bearing AF; ② Non-locating bearing AL; ③ Locating bearing BF; ④ Non-locating bearing BL

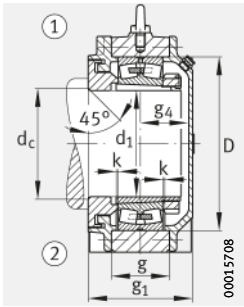

Design A
Housing with labyrinth seal

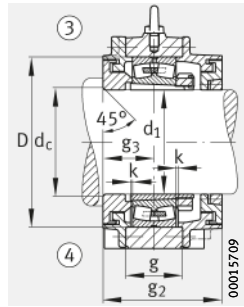

Design B

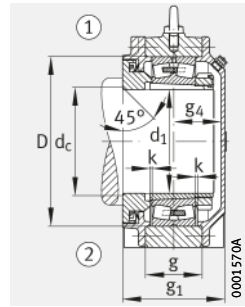

Design A
Housing with Taconite seal

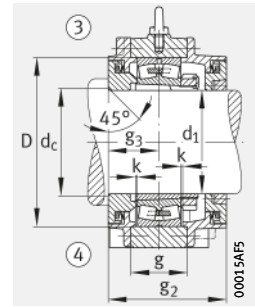

Design B

								Spherical roller bearing and accessories		Housing	
k	g ₁	g ₂	g ₃	g ₄ min.	t	S ₂		Bearing	Adapter sleeve	Mass m ≈ kg	Designation
							Quantity				
3	214	248	114	92	370	M16	8	22236...-K	H3136(-HG)	130	BND2236-H-C...S
3	176	201	88	80	310	M12	8	23036...-K	H3036(-HG)	70	BND3036-H-C...S
3	220	250	115	95	350	M16	8	23136...-K	H3136(-HG)	110	BND3136-H-C...S
3	240	274	127	105	370	M16	8	23236...-K	H2336(-HG)	140	BND3236-H-C...S
3	222	258	114	98	380	M16	8	22238...-K	H3138(-HG)	170	BND2238-H-C...S
3	181	211	93	80	325	M12	8	23038...-K	H3038(-HG)	80	BND3038-H-C...S
3	232	266	123	98	370	M16	8	23138...-K	H3138(-HG)	125	BND3138-H-C...S
3	250	286	128	112	380	M16	8	23228...-K	H2338(-HG)	170	BND3238-H-C...S
4	230	269	123	99	420	M16	8	22240...-K	H3140(-HG)	185	BND2240-H-C...S
3	196	226	98	90	340	M16	8	23040...-K	H3040(-HG)	95	BND3040-H-C...S
3	242	278	124	108	380	M16	8	23140...-K	H3140(-HG)	170	BND3140-H-C...S
4	260	299	138	114	420	M16	8	23240...-K	H2340(-HG)	205	BND3240-H-C...S
4	264	314	142	112	455	M20	8	22244...-K	H3144X(-HG)	290	BND2244-H-C...S
3	206	241	103	95	375	M16	8	23044...-K	H3044X(-HG)	100	BND3044-H-C...S
4	252	291	134	110	420	M16	8	23144...-K	H3144X(-HG)	190	BND3144-H-C...S
4	279	329	147	122	445	M20	8	23244...-K	H2344X(-HG)	240	BND3244-H-C...S
4	268	311	138	120	510	M20	8	22248...-K	H3148X(-HG)	315	BND2248-H-C...S
4	216	251	108	100	400	M16	8	23048...-K	H3048(-HG)	130	BND3048-H-C...S
4	284	334	152	122	455	M20	8	23148...-K	H3148X(-HG)	280	BND3148-H-C...S
4	308	351	158	140	510	M20	8	23248...-K	H2348X(-HG)	330	BND3248-H-C...S
3	286	326	148	126	535	M20	8	22252...-K	H3152X(-HG)	370	BND2252-H-C...S
4	226	261	113	103	440	M16	8	23052...-K	H3052X(-HG)	160	BND3052-H-C...S
4	292	335	150	132	510	M20	8	23152...-K	H3152X(-HG)	310	BND3152-H-C...S
3	330	370	170	148	535	M20	8	23252...-K	H2352X(-HG)	380	BND3252-H-C...S
4	297	354	157	128	555	M24	8	22256...-K	H3156X(-HG)	420	BND2256-H-C...S
4	236	281	118	108	460	M16	8	23056...-K	H3056(-HG)	180	BND3056-H-C...S
4	294	337	151	133	510	M20	8	23156...-K	H3156X(-HG)	335	BND3156-H-C...S
4	343	400	180	151	555	M24	8	23256...-K	H2356X(-HG)	490	BND3256-H-C...S



Plummer block housings

BND, unsplit
 For spherical roller bearings with tapered bore and adapter sleeve
 Stepped shaft

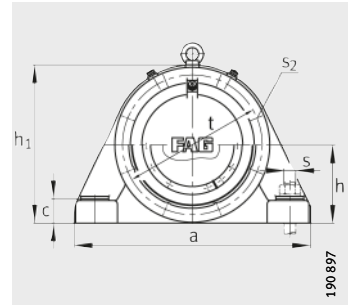
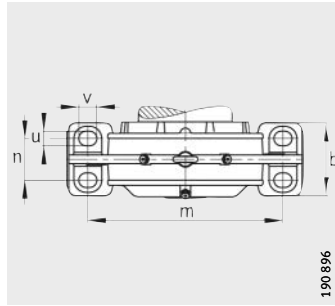

Dimension table (continued) · Dimensions in mm

Shaft		Housing Dimensions											
d ₁	d _c max.	h	h ₁	g	b	c	a	m	n	v	u	s	D
280	300	350	695	178	330	105	1 100	920	180	75	56	M48	540
280	296	285	570	140	250	85	820	690	150	52	42	M36	460
280	300	320	645	190	300	100	1 000	840	170	52	42	M36	500
280	300	350	705	230	330	105	1 100	920	180	75	56	M48	540
300	320	370	745	180	360	115	1 150	960	200	75	56	M48	580
300	316	295	590	150	260	90	860	730	160	52	42	M36	480
300	320	350	700	210	300	100	1 150	940	160	52	42	M36	540
300	320	370	745	238	360	115	1 150	960	200	75	56	M48	580
320	344	390	790	201	380	125	1 200	990	200	85	64	M56	620
320	340	315	630	160	270	95	900	770	170	52	42	M36	520
320	340	370	745	220	360	115	1 150	960	200	75	56	M48	580
320	344	390	790	260	380	125	1 200	990	200	85	64	M56	620
340	364	410	820	205	400	130	1 280	1 040	210	90	72	M64	650
340	360	330	660	170	280	100	960	820	180	52	42	M36	540
340	360	380	760	225	370	115	1 200	1 000	200	75	56	M48	600
340	364	410	820	267	400	130	1 280	1 040	210	90	72	M64	650
360	384	425	865	230	405	135	1 350	1 100	225	90	72	M64	680
360	380	340	680	160	300	105	1 000	840	190	75	56	M48	560
360	380	390	790	230	380	125	1 200	1 000	200	85	64	M56	620
360	384	425	860	295	405	135	1 350	1 100	225	90	72	M64	680
380	404	450	900	229	450	145	1 430	1 160	240	90	72	M64	720
380	400	360	720	175	320	110	1 060	900	200	75	56	M48	600
380	404	410	820	235	400	130	1 280	1 040	210	90	72	M64	650
380	404	450	900	300	450	145	1 430	1 160	240	90	72	M64	720
400	430	470	950	238	470	150	1 500	1 220	255	90	72	M64	760
400	420	375	755	180	340	115	1 100	940	210	75	56	M48	620
400	424	450	900	260	420	135	1 350	1 100	210	85	64	M56	700
400	430	470	950	315	470	150	1 500	1 220	255	90	72	M64	760

① Locating bearing AF; ② Non-locating bearing AL; ③ Locating bearing BF; ④ Non-locating bearing BL

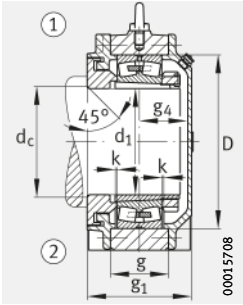

Design A
Housing with labyrinth seal

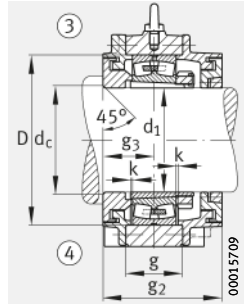

Design B

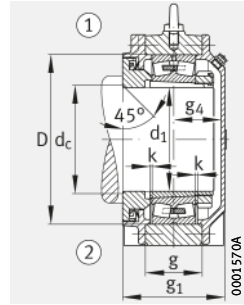

Design A
Housing with Taconite seal

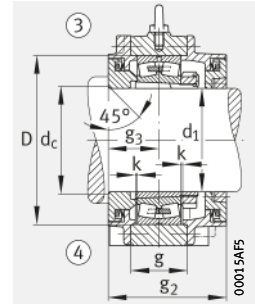

Design B

								Spherical roller bearing and accessories		Housing	
k	g ₁	g ₂	g ₃	g ₄ min.	t	s ₂	Quantity	Bearing	Adapter sleeve	Mass m ≈ kg	Designation
4	261	128	296	121	510	M16	8	23060...-K	H3060-(HG)	220	BND3060-H-C...-S
4	327	172	384	143	555	M24	8	23160...-K	H3160-(HG)	400	BND3160-H-C...-S
4	369	182	404	175	600	M24	8	23260...-K	H3260-(HG)	570	BND3260-H-C...-S
5	333	163	381	158	640	M24	8	22264...-K	H3164-HG	600	BND2264-H-C...-S
4	266	133	311	123	530	M16	8	23064...-K	H3064-HG	250	BND3064-H-C...-S
4	359	186	412	161	590	M24	8	23164...-K	H3164-HG	500	BND3164-H-C...-S
5	391	192	439	187	640	M24	8	23264...-K	H3264-HG	665	BND3264-H-C...-S
5	375	187,5	430	176	680	M30	8	22268...-K	H3168-HG	635	BND2268-H-C...-S
5	276	133	311	132	565	M20	8	23068...-K	H3068-HG	300	BND3068-H-C...-S
5	373	183	421	178	640	M24	8	23168...-K	H3168-HG	520	BND3168-H-C...-S
5	434	217	489	205	680	M30	8	23268...-K	H3268-HG	755	BND3268-H-C...-S
5	375	185	435	178	710	M30	8	22272...-K	H3172-HG	690	BND2272-H-C...-S
5	290	140	325	138	590	M20	8	23072...-K	H3072-HG	330	BND3072-H-C...-S
4	400	200	450	188	650	M24	8	23172...-K	H3172-HG	600	BND3172-H-C...-S
5	437	216	497	209	710	M30	8	23272...-K	H3272-HG	950	BND3272-H-C...-S
5	433	203	470	218	745	M30	8	22276...-K	H3176-HG	900	BND2276-H-C...-S
7	294	142	329	141	610	M20	8	23076...-K	H3076-HG	360	BND3076-H-C...-S
5	404	202	459	190	680	M30	8	23176...-K	H3176-HG	720	BND3176-H-C...-S
5	489	232	529	244	745	M30	8	23276...-K	H3276-HG	1 100	BND3276-H-C...-S
5	433	216,5	498	202	790	M30	8	22280...-K	H3180-HG	940	BND2280-H-C...-S
7	310	150	355	145	650	M20	8	23080...-K	H3080-HG	400	BND3080-H-C...-S
5	405	200	465	193	710	M30	8	23180...-K	H3180-HG	750	BND3180-H-C...-S
5	504	252	569	237	790	M30	8	23280...-K	H3280-HG	1 205	BND3280-H-C...-S
5	433	216,5	498	202	835	M30	8	22284...-K	H3184-HG	1 055	BND2284-H-C...-S
7	310	150	350	149	670	M20	8	23084...-K	H3084X-HG	435	BND3084-H-C...-S
7	440	210	510	215	760	M30	8	23184...-K	H3184-HG	950	BND3184-H-C...-S
5	510	255	575	240	835	M30	8	23284...-K	H3284-HG	1 310	BND3284-H-C...-S



Plummer block housings

BND, unsplit
For spherical roller bearings with cylindrical bore

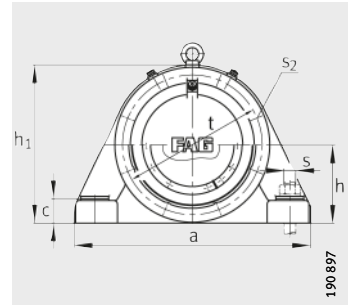
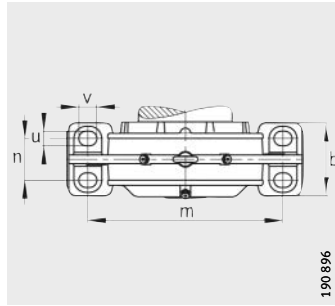

Dimension table - Dimensions in mm

Shaft		Housing Dimensions										
d	d _z max.	h	h ₁	g	b	c	a	m	n	v	u	s
65	71	80	155	44	70	22	235	185	40	20	15	M10
75	81	90	180	45	85	35	285	225	45	28	20	M16
90	98	110	220	55	110	38	370	290	60	32	23	M20
100	108	130	255	65	120	40	400	320	65	35	30	M24
110	118	140	280	73	130	42	440	350	70	35	30	M24
110	118	130	263	80	140	40	400	300	80	35	25	M20
110	118	140	280	89,8	130	42	440	350	70	35	30	M24
120	128	150	300	77	140	42	470	370	75	35	30	M24
120	128	115	230	60	110	35	370	300	60	35	25	M20
120	128	140	280	85	150	40	410	330	80	35	25	M20
120	128	150	300	95	140	42	470	370	75	35	30	M24
130	142	160	315	84	150	45	500	400	85	35	30	M24
130	138	130	260	70	120	38	410	340	60	35	25	M20
130	138	145	295	90	150	40	430	350	80	35	25	M20
130	142	160	315	100	150	45	500	400	85	35	30	M24
140	152	170	345	88	160	50	530	430	85	35	30	M24
140	148	140	275	70	130	40	430	360	70	35	30	M24
140	148	155	315	95	160	45	470	380	85	35	25	M20
140	152	170	345	108	160	50	530	430	85	35	30	M24
150	162	180	365	97	170	54	550	450	90	45	36	M30
150	158	145	290	80	140	42	455	370	80	35	30	M24
150	158	170	345	102	200	60	580	450	110	35	30	M24
150	162	180	365	120	170	54	550	450	90	45	36	M30
160	172	190	385	106	180	58	600	490	105	45	36	M30
160	168	155	310	85	150	45	480	390	90	35	30	M24
160	168	180	360	110	200	55	540	430	110	35	30	M24
160	172	190	385	130	180	58	600	490	105	45	36	M30
170	186	200	405	111	200	62	640	525	110	45	36	M30
170	178	165	330	90	160	50	510	420	95	45	36	M30
170	178	190	380	120	200	55	570	470	110	45	36	M30
170	186	200	405	135	200	62	640	525	110	45	36	M30

① Locating bearing AF; ② Non-locating bearing AL; ③ Locating bearing BF; ④ Non-locating bearing BL

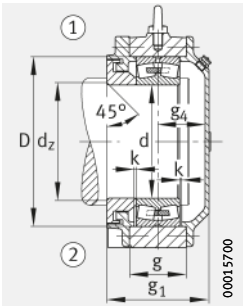

Design A
Housing with labyrinth seal

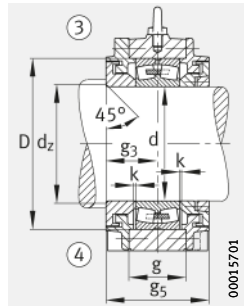

Design B

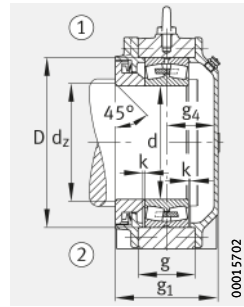

Design A
Housing with Taconite seal

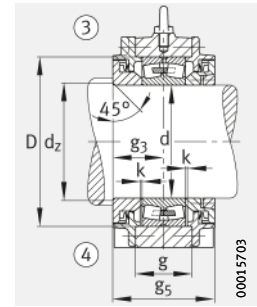

Design B

D	k	g ₁	g ₅	g ₃	g ₄ min.	t	S ₂		Spherical roller bearing	Housing	
								Quantity		Mass m ≈ kg	Designation
120	2	100	110	55	39	135	M6	6	22213	23	BND2213-Z..S
130	2	105	110	55	44	155	M6	6	22215	15	BND2215-Z..S
160	2	104	106	53	45	185	M8	6	22218	28	BND2218-Z..S
180	2,5	141	156	78	57	205	M8	6	22220	30	BND2220-Z..S
200	2,5	149,2	165,2	82,6	60	230	M12	6	22222	50	BND2222-Z..S
180	2,5	146	156	78	62	215	M12	8	23122	40	BND3122-Z..S
200	2,5	166	182	91	68	230	M12	6	23222	35	BND3222-Z..S
215	2,5	143	148	74	61	245	M12	6	22224	58	BND2224-Z..S
180	2,5	126	126	63	57	205	M8	8	23024	20	BND3024-Z..S
200	2,5	160	160	80	74	235	M12	8	23124	50	BND3124-Z..S
215	2,5	161	166	83	70	245	M12	6	23224	40	BND3224-Z..S
230	3	172	190	95	69	260	M12	6	22226	65	BND2226-Z..S
200	2	133	136	68	59	225	M10	8	23026	30	BND3026-Z..S
210	3	165	170	85	72	245	M12	8	23126	55	BND3126-Z..S
230	3	188	206	103	77	260	M12	6	23226	50	BND3226-Z..S
250	3	166	176	88	70	285	M16	6	22228	70	BND2228-Z..S
210	3	136	136	68	61	240	M10	8	23028	35	BND3028-Z..S
225	3	170	170	85	77	270	M12	8	23128	60	BND3128-Z..S
250	3	186	196	98	80	285	M16	6	23228	65	BND3228-Z..S
270	3	177	187	93,5	76	305	M16	6	22230	85	BND2230-Z..S
225	2	149	156	78	64	250	M12	8	23030	40	BND3030-Z..S
250	2	186	186	93	85	285	M12	8	23130	70	BND3130-Z..S
270	3	200	210	105	87	305	M16	6	23230	75	BND3230-Z..S
290	3	189	206	103	78	330	M16	6	22232	100	BND2232-Z..S
240	3	156	156	78	71	265	M12	8	23032	45	BND3032-Z..S
270	3	200	210	105	87	310	M16	6	23132	80	BND3132-Z..S
290	3	213	230	115	90	330	M16	6	23232	90	BND3232-Z..S
310	3	216	236	118	88	350	M16	8	22234	105	BND2234-Z..S
260	2	166	166	83	75	285	M12	8	23034	70	BND3034-Z..S
280	3	215	230	115	90	330	M12	8	23134	100	BND3134-Z..S
310	3	240	260	130	100	350	M16	8	23234	120	BND3234-Z..S



Plummer block housings

BND, unsplit
For spherical roller bearings with cylindrical bore

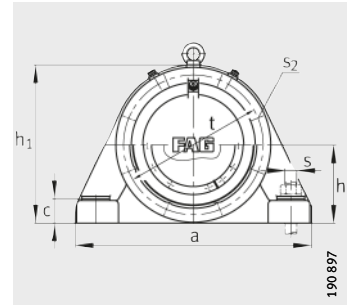
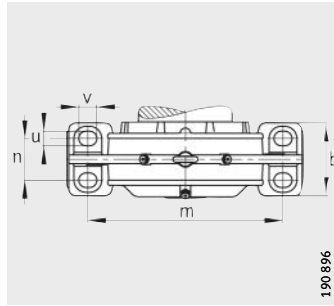

Dimension table (continued) · Dimensions in mm

Shaft		Housing Dimensions										
d	d _z	h	h ₁	g	b	c	a	m	n	v	u	s
	max.											
180	196	210	425	112	210	65	680	550	120	45	36	M30
180	188	180	360	100	170	52	540	450	100	45	36	M30
180	192	200	395	125	200	58	600	490	105	45	36	M30
180	196	210	425	138	210	65	680	550	120	45	36	M30
190	206	220	455	115	220	85	710	560	120	52	42	M36
190	198	185	370	105	180	55	570	480	105	45	36	M30
190	202	210	425	130	210	65	680	550	120	45	36	M30
190	206	220	455	143	220	85	710	560	120	52	42	M36
200	216	235	475	128	240	75	780	640	140	52	42	M36
200	208	200	400	110	190	60	600	510	110	45	36	M30
200	212	220	455	135	220	85	710	560	120	52	42	M36
200	216	235	475	158	240	75	780	640	140	52	42	M36
220	236	270	550	140	250	80	890	720	140	52	42	M36
220	232	215	430	115	200	65	640	540	115	52	42	M36
220	236	235	475	150	240	75	780	640	140	52	42	M36
220	236	260	525	175	250	80	850	700	140	52	42	M36
240	256	290	585	150	250	90	900	750	140	52	42	M36
240	252	225	455	120	210	70	680	560	120	52	42	M36
240	256	270	550	160	250	80	890	720	140	52	42	M36
240	256	290	585	190	250	90	900	750	140	52	42	M36
260	280	310	625	161	290	95	960	800	160	52	42	M36
260	276	250	500	130	220	75	720	600	130	52	42	M36
260	276	290	585	174	250	90	900	750	140	52	42	M36
260	280	310	625	205	290	95	960	800	160	52	42	M36
280	300	320	645	160	300	100	1000	840	170	52	42	M36
280	296	260	520	135	240	80	760	630	140	52	42	M36
280	300	290	585	176	250	90	900	750	140	52	42	M36
280	300	320	645	206	300	100	1000	840	170	52	42	M36

① Locating bearing AF; ② Non-locating bearing AL; ③ Locating bearing BF; ④ Non-locating bearing BL

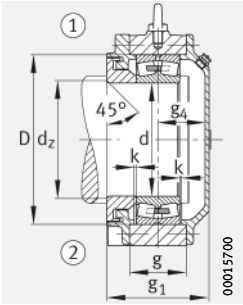

Design A
Housing with labyrinth seal

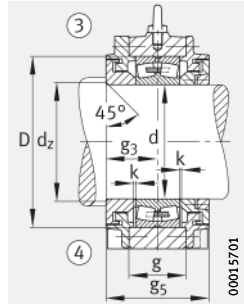

Design B

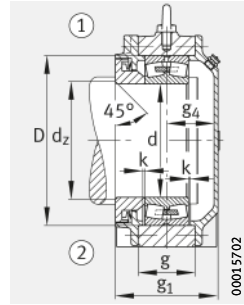

Design A
Housing with Taconite seal

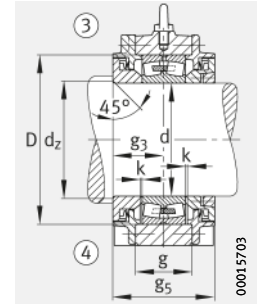

Design B

D	k	g ₁	g ₅	g ₃	g ₄	t	S ₂		Spherical roller bearing	Housing	
								Quantity		Mass m ≈ kg	Designation
320	3	214	228	114	92	370	M16	8	22236	130	BND2236-Z...S
280	3	176	176	88	80	310	M12	8	23036	70	BND3036-Z...S
300	3	220	230	115	95	350	M16	8	23136	110	BND3136-Z...S
320	3	240	254	127	105	370	M16	8	23236	140	BND3236-Z...S
340	3	222	228	114	98	380	M16	8	22238	170	BND2238-Z...S
290	3	181	186	93	80	325	M12	8	23038	80	BND3038-Z...S
320	3	232	246	123	98	370	M16	8	23138	125	BND3138-Z...S
340	3	250	256	128	112	380	M16	8	23228	170	BND3238-Z...S
360	4	230	246	123	99	420	M16	8	22240	185	BND2240-Z...S
310	3	196	196	98	90	340	M16	8	23040	95	BND3040-Z...S
340	3	242	248	124	108	380	M16	8	23140	170	BND3140-Z...S
360	4	260	276	138	114	420	M16	8	23240	205	BND3240-Z...S
400	4	264	284	142	112	455	M20	8	22244	290	BND2244-Z...S
340	3	206	206	103	95	375	M16	8	23044	100	BND3044-Z...S
370	4	252	268	134	110	420	M16	8	23144	190	BND3144-Z...S
400	4	279	294	147	122	445	M20	8	23244	240	BND3244-Z...S
440	4	268	276	138	120	510	M20	8	22248	315	BND2248-Z...S
360	4	216	216	108	100	400	M16	8	23048	130	BND3048-Z...S
400	4	284	304	152	122	455	M20	8	23148	280	BND3148-Z...S
440	4	308	316	158	140	510	M20	8	23248	330	BND3248-Z...S
480	3	286	296	148	126	535	M20	8	22252	370	BND2252-Z...S
400	4	226	226	113	103	440	M16	8	23052	160	BND3052-Z...S
440	4	292	300	150	132	510	M20	8	23152	310	BND3152-Z...S
480	3	330	340	170	148	535	M20	8	23252	380	BND3252-Z...S
500	4	297	314	157	128	555	M24	8	22256	420	BND2256-Z...S
420	4	236	236	118	108	460	M16	8	23056	180	BND3056-Z...S
460	4	294	302	151	133	510	M20	8	23156	335	BND3156-Z...S
500	4	343	360	180	151	555	M24	8	23256	490	BND3256-Z...S



Plummer block housings

BND, unsplit
For spherical roller bearings with cylindrical bore

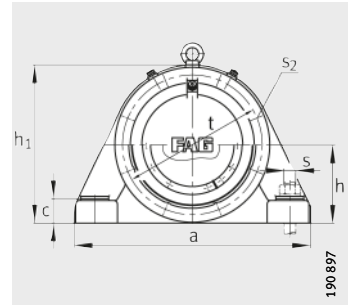
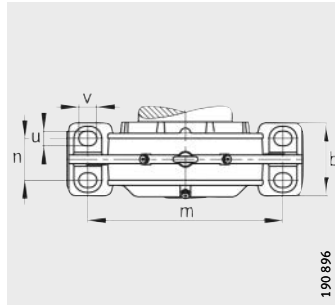

Dimension table (continued) · Dimensions in mm

Shaft		Housing Dimensions										
d	d ₂	h	h ₁	g	b	c	a	m	n	v	u	s
	max.											
300	320	350	695	178	330	105	1 100	920	180	75	56	M48
300	316	285	570	140	250	85	820	690	150	52	42	M36
300	320	320	645	190	300	100	1 000	840	170	52	42	M36
300	320	350	705	230	330	105	1 100	920	180	75	56	M48
320	340	370	745	180	360	115	1 150	960	200	75	56	M48
320	336	295	590	150	260	90	860	730	160	52	42	M36
320	340	350	700	210	300	100	1 150	940	160	52	42	M36
320	340	370	745	238	360	115	1 150	960	200	75	56	M48
340	364	390	790	201	380	125	1 200	990	200	85	64	M56
340	360	315	630	160	270	95	900	770	170	52	42	M36
340	360	370	745	220	360	115	1 150	960	200	75	56	M48
340	364	390	790	260	380	125	1 200	990	200	85	64	M56
360	384	410	820	205	400	130	1 280	1 040	210	90	72	M64
360	380	330	660	170	280	100	960	820	180	52	42	M36
360	380	380	760	225	370	115	1 200	1 000	200	75	56	M48
360	384	410	820	267	400	130	1 280	1 040	210	90	72	M64
380	404	425	865	230	405	135	1 350	1 100	225	90	72	M64
380	400	340	680	160	300	105	1 000	840	190	75	56	M48
380	400	390	790	230	380	125	1 200	1 000	200	85	64	M56
380	404	425	860	295	405	135	1 350	1 100	225	90	72	M64
400	424	450	900	229	450	145	1 430	1 160	240	90	72	M64
400	420	360	720	175	320	110	1 060	900	200	75	56	M48
400	424	410	820	235	400	130	1 280	1 040	210	90	72	M64
400	424	450	900	300	450	145	1 430	1 160	240	90	72	M64
420	450	470	950	238	470	150	1 500	1 220	255	90	72	M64
420	440	375	755	180	340	115	1 100	940	210	75	56	M48
420	444	450	900	260	420	135	1 350	1 100	210	85	64	M56
420	450	470	950	315	470	150	1 500	1 220	255	90	72	M64

① Locating bearing AF; ② Non-locating bearing AL; ③ Locating bearing BF; ④ Non-locating bearing BL

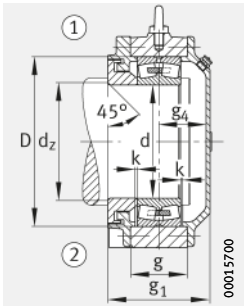

Design A
Housing with labyrinth seal

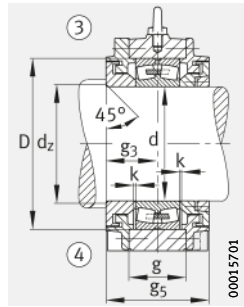

Design B

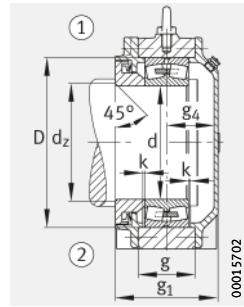

Design A
Housing with Taconite seal

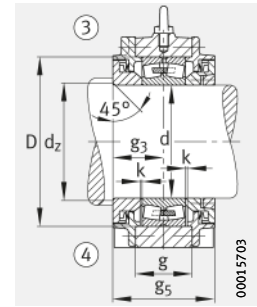

Design B

D	k	g ₁	g ₅	g ₃	g ₄ min.	t	S ₂		Spherical roller bearing	Housing	
								Quantity		Mass m ≈ kg	Designation
540	4	317	312	352	149	600	M24	8	22260	485	BND2260-Z...-S
460	4	261	256	296	121	510	M16	8	23060	220	BND3060-Z...-S
500	4	327	344	384	143	555	M24	8	23160	400	BND3160-Z...-S
540	4	369	364	404	175	600	M24	8	23260	570	BND3260-Z...-S
580	5	333	326	381	158	640	M24	8	22264	600	BND2264-Z...-S
480	4	266	266	311	123	530	M16	8	23064	250	BND3064-Z...-S
540	4	359	372	412	161	590	M24	8	23164	500	BND3164-Z...-S
580	5	391	384	439	187	640	M24	8	23264	665	BND3264-Z...-S
620	5	375	375	430	176	680	M30	8	22268	635	BND2268-Z...-S
520	5	276	266	311	132	565	M20	8	23068	300	BND3068-Z...-S
580	5	373	366	421	178	640	M24	8	23168	520	BND3168-Z...-S
620	5	434	434	489	205	680	M30	8	23268	755	BND3268-Z...-S
650	5	375	370	435	178	710	M30	8	22272	690	BND2272-Z...-S
540	5	290	280	325	138	590	M20	8	23072	330	BND3072-Z...-S
600	4	400	400	450	188	650	M24	8	23172	600	BND3172-Z...-S
650	5	437	432	497	209	710	M30	8	23272	950	BND3272-Z...-S
680	5	433	406	470	218	745	M30	8	22276	900	BND2276-Z...-S
560	7	294	284	329	141	610	M20	8	23076	360	BND3076-Z...-S
620	5	404	404	459	190	680	M30	8	23176	720	BND3176-Z...-S
680	5	489	464	529	244	745	M30	8	23276	1100	BND3276-Z...-S
720	5	433	433	498	202	790	M30	8	22280	940	BND2280-Z...-S
600	7	310	300	355	145	650	M20	8	23080	400	BND3080-Z...-S
650	5	405	400	465	193	710	M30	8	23180	750	BND3180-Z...-S
720	5	504	504	569	237	790	M30	8	23280	1205	BND3280-Z...-S
760	5	433	433	498	202	835	M30	8	22284	1055	BND2284-Z...-S
620	7	310	300	350	149	670	M20	8	23084	435	BND3084-Z...-S
700	7	440	420	510	215	760	M30	8	23184	950	BND3184-Z...-S
760	5	510	510	575	240	835	M30	8	23284	1310	BND3284-Z...-S



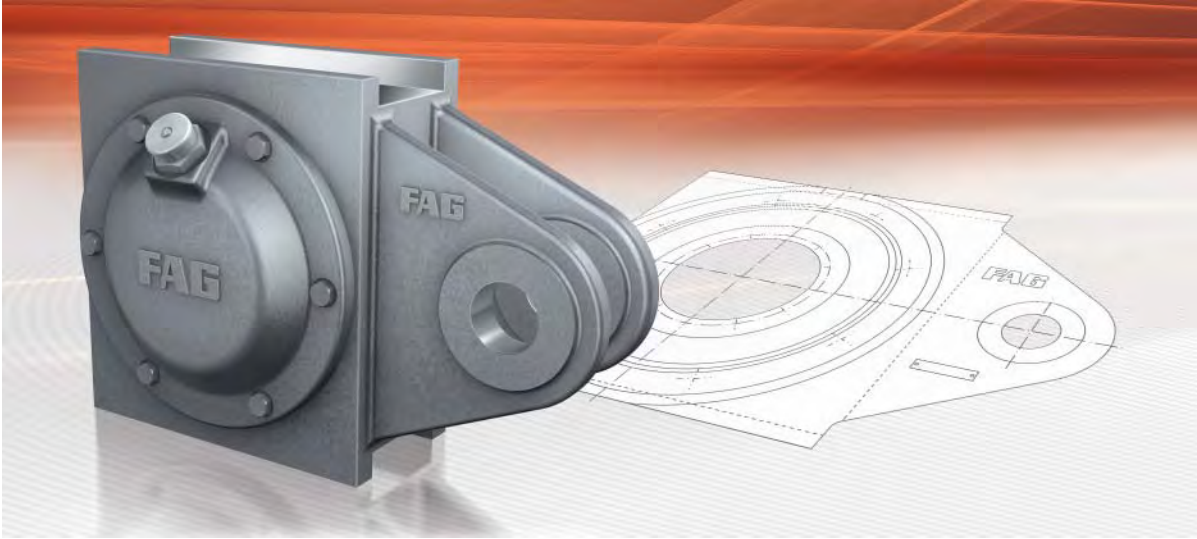

Take-up housings SPA

Take-up housings SPA

	Page
Product overview	Take-up housings SPA 336
Features	Suitable bearings 337
	Housing materials and anti-corrosion protection 337
	Locating and non-locating bearings 337
	Seals and covers 338
	Housing configurations..... 338
	Lubrication 341
	Designation structure 342
	Ordering examples 343
Accuracy 343
Dimension tables	Take-up housings SPA, unsplit, for spherical roller bearings with tapered bore and adapter sleeve..... 344
	Take-up housings SPA, unsplit, for spherical roller bearings with tapered bore and adapter sleeve, stepped shaft..... 348



Product overview Take-up housings SPA

Take-up housings

Unsplit

Closed on one side, with cover

SPA..-AF, SPA..-AL

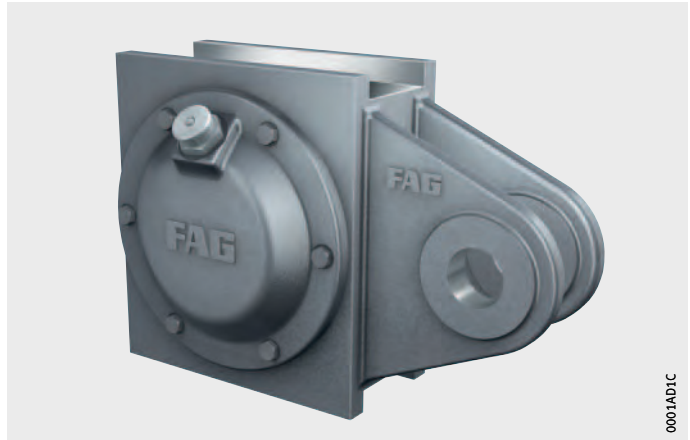

For continuous shaft

SPA..-BF, SPA..-BL

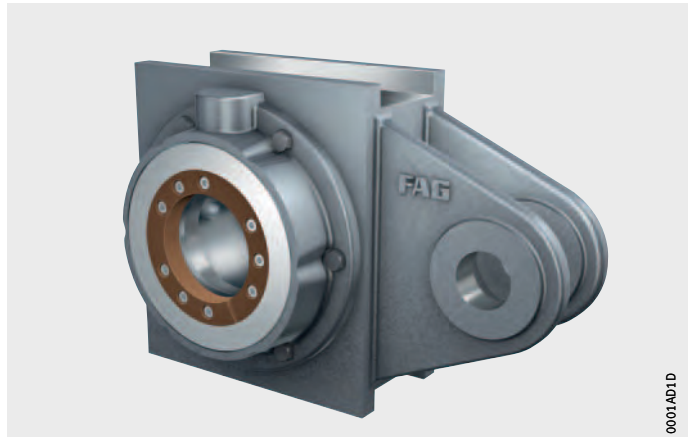

Take-up housings SPA

Features Take-up housings SPA are combined with FAG spherical roller bearings, seals and grease filling to form bearing units for very high loads.

The housings are unsplit. They were developed specifically for tensioner drum bearing arrangements in belt conveyor plant. There is a yoke-shaped drawbar eye for attachment to the tensioning device. The housing is guided by means of rails in the belt support structure.

Suitable bearings The dimensions of take-up housings SPA are matched to spherical roller bearings 222..-K, 230..-K, 231..-K and 232..-K, see table. The range of shaft diameters is between 50 mm and 400 mm.

Bearing type and sizes

Bearing type	Size
Spherical roller bearings	22211..-K to 22228..-K
■ with tapered bore and adapter sleeve	23028..-K to 23056..-K
	23132..-K to 23176..-K
	23222..-K to 23284..-K

Housing materials and anti-corrosion protection The standard material for the housing bodies is cast steel (suffix S). By agreement, housing bodies made from spheroidal graphite cast iron (suffix D) are available.

All outer surfaces not machined by chip-forming methods have a universal paint coating (colour RAL 7031, bluish-grey). The coating can be finished using all synthetic resin, polyurethane, acrylic, epoxy resin, chlorinated rubber, nitrocellulose and acid-hardening hammer tone finishes.

Inner and outer surfaces machined by chip-forming methods are provided with anti-corrosion protection that can be easily removed. It is recommended that only volatile solvents and lint-free cloths should be used.



Locating and non-locating bearings The housings are supplied as a locating bearing design or non-locating bearing design. In the locating bearing, the bearing is clamped between the housing covers. In the non-locating bearing, the bearing can align itself axially, since the covers have shorter centring collars.

Take-up housings SPA

Seals and covers

Take-up housings SPA of design A are intended for the bearing arrangements of shaft ends. One side is closed by a cover and the other side is sealed against the shaft. Design B is intended for continuous shafts, in which case the housing is sealed against the shaft on both sides.

Labyrinth seals (suffix Y) or Taconite seals (suffix T) can be used, *Figure 1*. Where shafts of constant diameter are used, the seals are located on the shaft by means of slotted conical clamping rings made from laminated fabric. The labyrinth rings, Taconite seals and covers are unsplit.

The seals allow shaft misalignment of up to $0,5^\circ$ in both directions and are suitable for grease lubrication.

- ① Labyrinth seal
- ② Taconite seal

Figure 1
Seals for take-up housings SPA

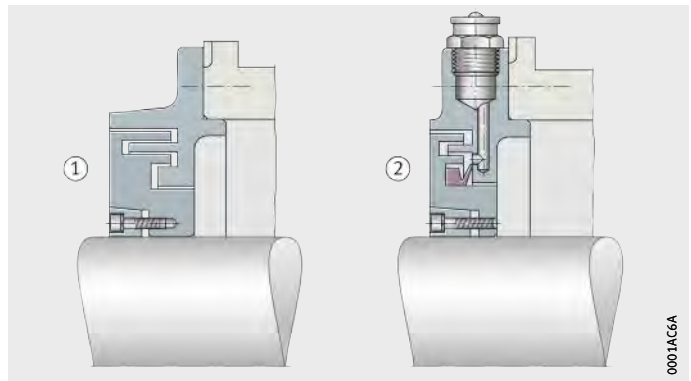

Housing configurations

In the case of take-up housings SPA, various housing configurations are possible that are clearly described by means of the designation, *Figure 2*, page 339 to *Figure 9*, page 340.

The following features can be varied in the housing configuration:

- location of bearings with a tapered bore by means of an adapter sleeve on a shaft of constant diameter or on a stepped shaft
- sealing of the housing by means of a labyrinth seal or a Taconite seal
- continuous shaft or a housing closed on one side
- design of the bearing arrangement as a locating bearing arrangement or a non-locating bearing arrangement.

- ① Locating bearing SPA...H-W-Y-AF
- ② Non-locating bearing SPA...H-W-Y-AL

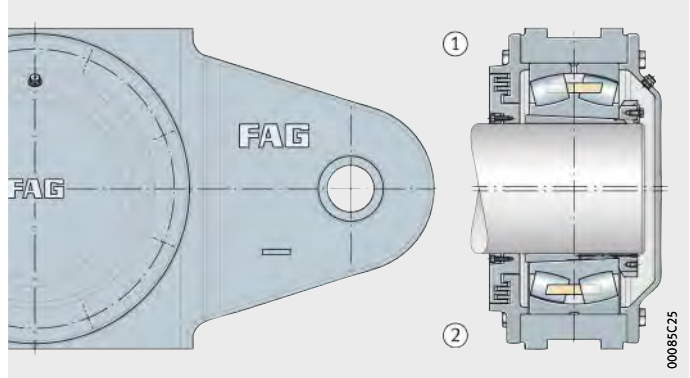

Figure 2

Take-up housing SPA for bearings with tapered bore and adapter sleeve (labyrinth seal), design A

- ① Locating bearing SPA...H-W-Y-BF
- ② Non-locating bearing SPA...H-W-Y-BL

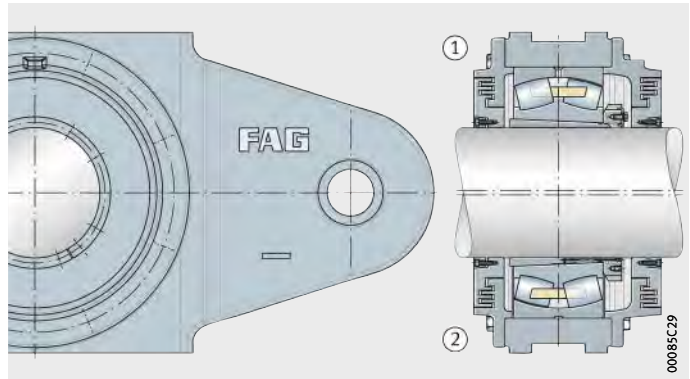

Figure 3

Take-up housing SPA for bearings with tapered bore and adapter sleeve (labyrinth seal), design B

- ① Locating bearing SPA...H-W-T-AF
- ② Non-locating bearing SPA...H-W-T-AL

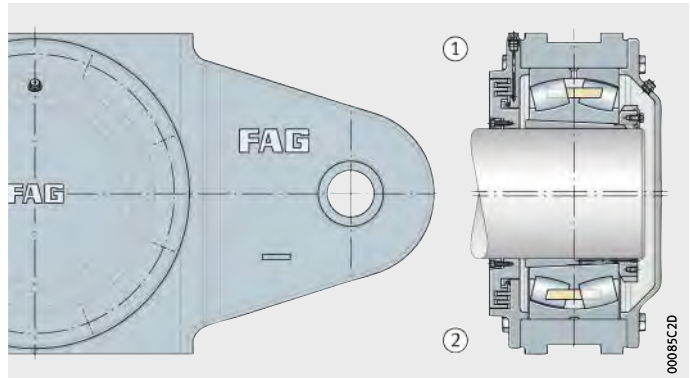

Figure 4

Take-up housing SPA for bearings with tapered bore and adapter sleeve (Taconite seal), design A

- ① Locating bearing SPA...H-W-T-BF
- ② Non-locating bearing SPA...H-W-T-BL

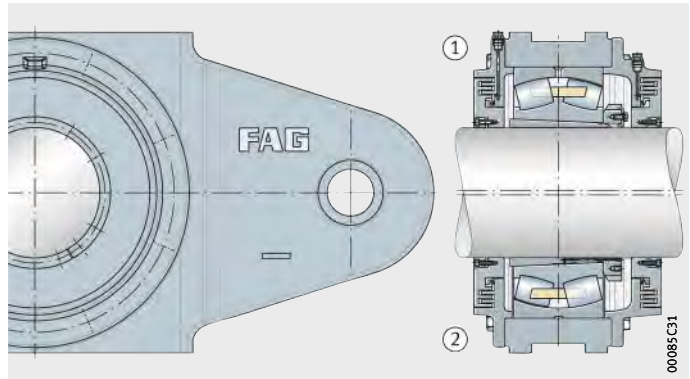

Figure 5

Take-up housing SPA for bearings with tapered bore and adapter sleeve (Taconite seal), design B



Take-up housings SPA

- ① Locating bearing SPA...-H-C-Y-AF
- ② Non-locating bearing SPA...-H-C-Y-AL

Figure 6
Take-up housing SPA for bearings with tapered bore and adapter sleeve for stepped shaft (labyrinth seal), design A

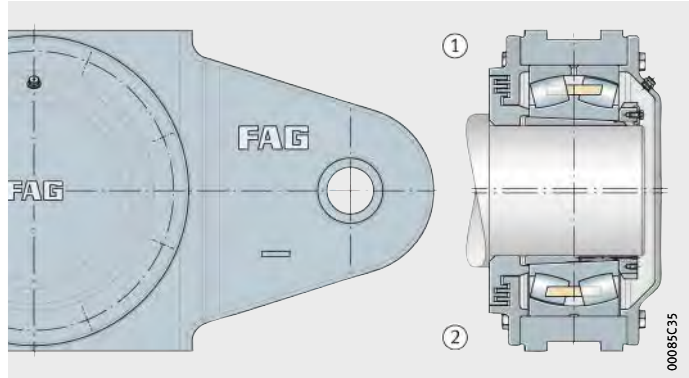

- ① Locating bearing SPA...-H-C-Y-BF
- ② Non-locating bearing SPA...-H-C-Y-BL

Figure 7
Take-up housing SPA for bearings with tapered bore and adapter sleeve for stepped shaft (labyrinth seal), design B

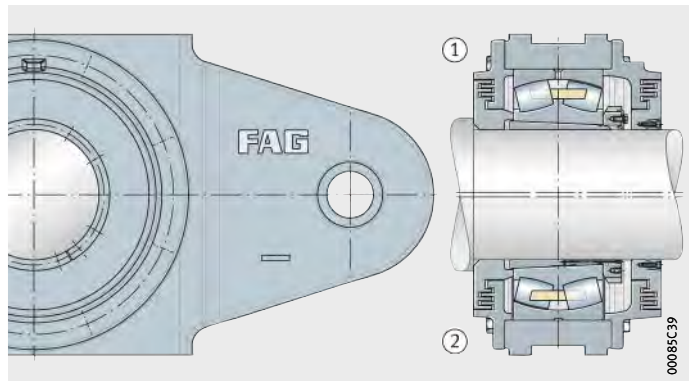

- ① Locating bearing SPA...-H-C-T-AF
- ② Non-locating bearing SPA...-H-C-T-AL

Figure 8
Take-up housing SPA for bearings with tapered bore and adapter sleeve for stepped shaft (Taconite seal), design A

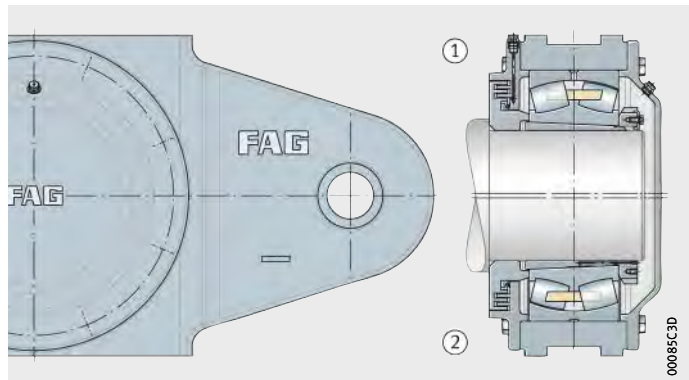

- ① Locating bearing SPA...-H-C-T-BF
- ② Non-locating bearing SPA...-H-C-T-BL

Figure 9
Take-up housing SPA for bearings with tapered bore and adapter sleeve for stepped shaft (Taconite seal), design B

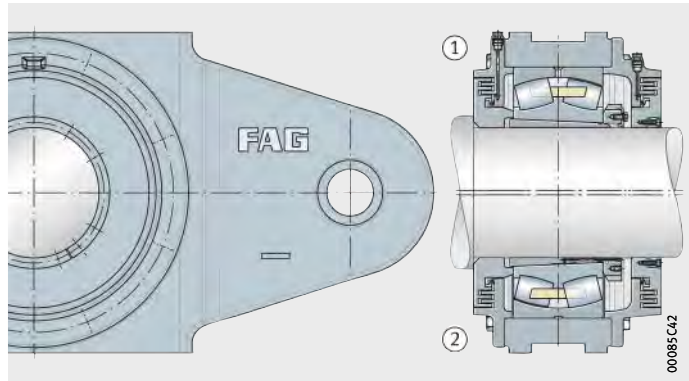

Lubrication Take-up housings SPA are designed for grease lubrication.

Greases Suitable greases are lithium soap greases of NLGI grades 2 and 3, for example Arcanol MULTI3 for low loads and Arcanol MULTITOP and LOAD400 for high and very high loads.

Grease quantities In initial lubrication, the cavities in the bearing, the housing and the labyrinths are completely filled with grease. This is the basis for the recommended grease quantities, see table.

For relubrication, it is recommended that the grease quantity is approx. 10% of the grease quantity used in initial greasing. If the ambient conditions lead to heavy contamination of the housings, relubrication should be carried out on a daily basis using smaller quantities.

Recommended grease quantity

Bearing bore mm	Grease quantity for initial greasing	
	SPA22, SPA31, SPA32 ≈ g	SPA30 ≈ g
180	2 500	–
190	3 000	–
200	3 600	–
220	4 200	1 900
240	5 000	2 100
260	6 000	2 500
280	7 000	3 000
300	8 000	3 500
320	9 000	4 100
340	10 500	4 800
360	12 000	5 500
380	13 000	6 200
400	14 500	7 000
420	16 000	8 000



Relubrication The housings have button head lubrication nipples with a head diameter standardised to DIN 3404 of 22 mm. The grease is fed uniformly to both rows of rollers via the circumferential slot and three lubrication holes in the outer ring of the spherical roller bearings.

The relubrication intervals should be matched to the ambient conditions. The bearings should be relubricated after an interval of no more than 4 weeks.

Take-up housings SPA

Designation structure

Designation structure of take-up housings SPA, see table and Figure 10.

Designation structure of take-up housings SPA

Feature	Code	Description
① Series	SPA	Take-up housings SPA
② ISO dimension series of bearing	22	ISO dimension series 22
③ Bore code of bearing	13	Bore diameter (13 · 5) mm = 65 mm
④ Bearing bore	H	Tapered bearing bore and adapter sleeve
⑤ Shaft	W	Shaft of constant diameter
	C	Stepped shaft
⑥ Seal	Y	Labyrinth seal
	T	Taconite seal
⑦ Housing design	AF	Closed on one side, locating bearing
	AL	Closed on one side, non-locating bearing
	BF	Continuous shaft, locating bearing
	BL	Continuous shaft, non-locating bearing
⑧ Housing material	S	Cast steel (standard)
	D	Spheroidal graphite cast iron



Figure 10
Designation structure of take-up housings SPA, example

Ordering examples

When ordering a take-up housing SPA, the designation contains indications of the size and location method of the bearing, the shaft design, the sealing variant and the design and material of the housing. The rolling bearing and, if necessary, the adapter sleeve must be ordered separately.

The ordering examples show the construction of orders for selected housing configurations and the appropriate bearings. The allocation of housings, bearings and adapter sleeves for all housing sizes is shown in the dimension tables.

Example 1 Take-up housing SPA made from cast steel, for continuous shaft of constant diameter, labyrinth seal, spherical roller bearing 23260-K-MB as locating bearing, location using adapter sleeve.

Order	1 take-up housing	SPA3260-H-W-Y-BF-S
	1 spherical roller bearing	23260-K-MB
	1 adapter sleeve	H3260-HG

Example 2 Take-up housing SPA made from cast steel, closed on one side, for stepped shaft, Taconite seal, spherical roller bearing 23284-B-K-MB as non-locating bearing, location using adapter sleeve.

Order	1 take-up housing	SPA3284-H-C-T-AL-S
	1 spherical roller bearing	23284-B-K-MB
	1 adapter sleeve	H3284-HG

Accuracy The bearing seat in take-up housings SPA is machined to the tolerance class H7.

By agreement, the housings can also be supplied with other tolerance classes for the bearing seat, see section Tolerance class of bearing seat, page 47.



Take-up housings

SPA, unsplit
 For spherical roller bearings
 with tapered bore and
 adapter sleeve

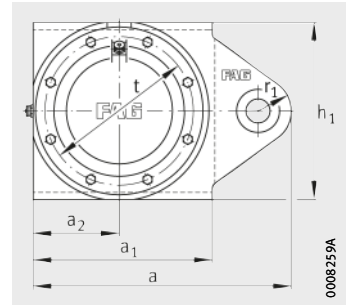
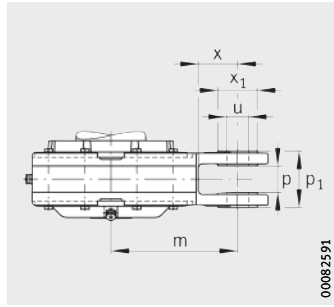

Dimension table - Dimensions in mm

Shaft d_1	Housing Dimensions														
	h_1	a	a_1	a_2	g_1	g_2	m	r_1	x	x_1	u	p	p_1	f	f_1
50	150	210	150	75	92,5	115	105	30	30	-	20	22	42	135	34
55	165	237,5	165	82,5	102,5	125	120	35	37,5	-	25	26	50	150	35
60	180	265	160	80	134	144	145	40	65	60	30	30	66	155	53
70	200	285	180	90	125	138	155	40	65	60	30	30	66	175	53
80	230	315	210	105	119	138	170	40	65	60	30	30	66	200	53
90	250	342,5	235	117,5	141	168	185	40	67,5	65	35	36	70	220	40
100	270	380	265	135	149,2	177,2	200	45	70	70	40	40	76	240	53
110	290	395	280	140	143	168	210	45	70	70	40	40	76	260	53
125	330	445	320	160	166	196	230	55	70	70	40	40	76	300	53
125	300	425	260	130	136	156	225	70	90	90	50	60	150	270	45
135	320	445	280	140	149	176	235	70	95	90	50	60	150	290	45
140	370	625	370	185	216	229	350	90	160	100	60	62	132	340	75
150	360	492,5	325	162,5	178	203	260	70	90	90	50	60	150	330	65
150	400	672,5	375	187,5	215	250	395	90	180	100	60	62	132	370	65
160	370	540	375	180	176	201	290	70	90	90	50	60	130	340	60
160	450	600	420	210	240	274	300	90	90	120	80	72	140	410	93
170	440	550	385	190	181	211	290	70	90	90	50	60	150	400	65
180	440	550	385	190	201	241	290	70	90	90	50	60	150	400	65
180	440	650	420	210	242	278	360	80	140	100	60	70	140	410	100
180	500	650	470	235	260	299	325	90	85	120	80	72	140	460	103
200	480	615	430	210	206	241	325	80	100	100	60	70	200	440	65
200	510	885	470	235	252	291	530	120	260	160	100	74	144	480	105
200	540	940	520	260	279	329	530	150	250	140	100	130	200	500	90
220	540	925	520	260	276	326	515	150	250	160	100	123	215	500	65
220	580	970	560	280	308	351	540	150	260	140	100	130	220	545	95

① Locating bearing AF; ② Non-locating bearing AL; ③ Locating bearing BF; ④ Non-locating bearing BL

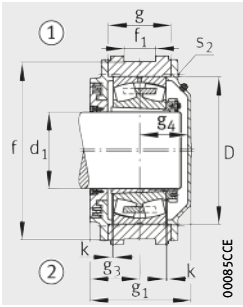

Guidance on both sides
Design A
Housing with labyrinth seal

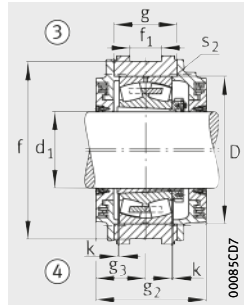

Guidance on both sides
Design B

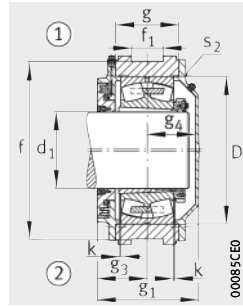

Guidance on both sides
Design A
Housing with Taconite seal

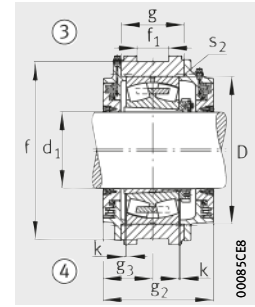

Guidance on both sides
Design B

								Spherical roller bearing and accessories		Housing	
D	k	g	g ₃	g ₄	t	S ₂		Bearing	Adapter sleeve	Mass m ≈ kg	Designation
							Quantity				
100	2	45	52,5	35	130	M8	6	22211...-K	H311	9	SPA2211...-S
110	2	55	57,5	40	135	M8	6	22212...-K	H312	12	SPA2212...-S
120	2	78	72	56	135	M6	6	22213...-K	H313	16	SPA2213...-S
140	2	78	69	49	155	M8	8	22216...-K	H316	25	SPA2216...-S
160	2	70	60,5	52,5	185	M8	6	22218...-K	H318	22	SPA2218...-S
180	2,5	65	78	57	205	M8	6	22220...-K	H320	26	SPA2220...-S
200	2,5	73	82,6	60,6	230	M12	6	22222...-K	H322	32	SPA2222...-S
215	2,5	77	74	61	245	M12	6	22224...-K	H3124	39	SPA2224...-S
250	3	88	88	70	285	M16	6	22228...-K	H3128	58	SPA2228...-S
210	3	70	68	61	240	M10	8	23028...-K	H3028	53	SPA3028...-S
225	2	80	78	64	250	M12	8	23030...-K	H3030	65	SPA3030...-S
270	3	116	108	100	300	M12	8	23132...-K	H3132(-HG)	120	SPA3132...-S
260	2	102	89	81	285	M12	8	23034...-K	H3034(-HG)	90	SPA3034...-S
280	3	120	115	92	330	M12	8	23134...-K	H3134(-HG)	131	SPA3134...-S
280	3	100	88	80	310	M12	8	23036...-K	H3036(-HG)	85	SPA3036...-S
320	3	138	127	105	370	M16	8	23236...-K	H2336(-HG)	158	SPA3236...-S
290	3	105	93	80	325	M16	8	23038...-K	H3038(-HG)	129,5	SPA3038...-S
310	3	105	105,5	87,5	340	M16	8	23040...-K	H3040(-HG)	180	SPA3040...-S
340	3	135	124	108	380	M16	8	23140...-K	H3140(-HG)	165	SPA3140...-S
360	4	158	138	114	420	M16	8	23240...-K	H2340(-HG)	260	SPA3240...-S
340	3	115	103	95	375	M16	8	23044...-K	H3044X(-HG)	180	SPA3044...-S
370	4	150	134	110	420	M16	8	23144...-K	H3144X(-HG)	280	SPA3144...-S
400	4	175	147	122	445	M20	8	23244...-K	H2344X(-HG)	325	SPA3244...-S
400	4	152	148	122	455	M20	8	23148...-K	H3148X(-HG)	330	SPA3148...-S
440	4	190	158	140	510	M20	8	23248...-K	H2348X(-HG)	430	SPA3248...-S



Take-up housings

SPA, unsplit
 For spherical roller bearings
 with tapered bore and
 adapter sleeve

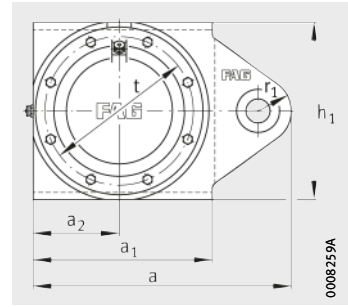
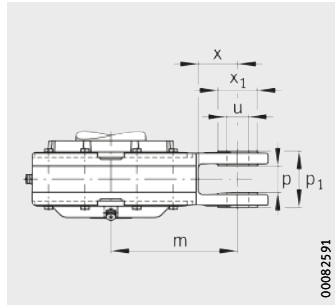

Dimension table (continued) · Dimensions in mm

Shaft d_1	Housing Dimensions														
	h_1	a	a_1	a_2	g_1	g_2	m	r_1	x	x_1	u	p	p_1	f	f_1
240	540	910	500	245	226	261	515	150	250	140	100	123	215	500	65
240	570	990	550	275	291	336	565	150	270	160	100	135	225	540	80
240	610	1 063	596	298	330	370	615	150	300	140	100	173	240	570	103
260	540	910	500	245	236	281	515	150	250	140	100	123	215	500	65
260	650	1 095	630	315	343	400	630	150	220	140	100	173	240	610	123
280	650	1 115	630	315	327	385	650	150	310	140	100	170	270	610	130
280	690	1 200	680	340	369	404	680	180	310	140	100	190	270	650	115
300	670	1 140	665	340	359	412	650	150	310	175	100	170	240	630	123
300	710	1 280	710	355	391	439	725	200	275	170	110	213	300	670	123
320	740	1 290	740	370	373	421	720	200	310	180	120	180	300	700	150
320	740	1 335	735	385	434	489	750	200	310	170	110	213	300	700	123
340	830	1 390	800	400	437	497	765	225	310	190	130	213	330	790	123
360	790	1 325	750	375	404	459	750	200	320	170	110	200	300	740	120
360	820	1 385	810	405	489	529	780	200	305	170	110	213	300	780	123
380	960	1 460	880	440	504	569	820	200	350	170	110	180	300	900	190
400	960	1 488	925	465	510	575	825	200	350	170	110	180	300	900	190

① Locating bearing AF; ② Non-locating bearing AL; ③ Locating bearing BF; ④ Non-locating bearing BL

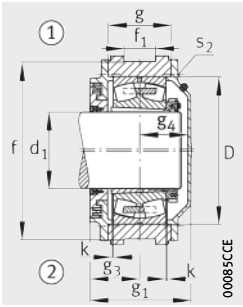

Guidance on both sides
Design A
Housing with labyrinth seal

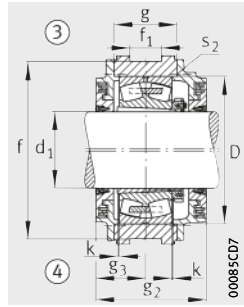

Guidance on both sides
Design B

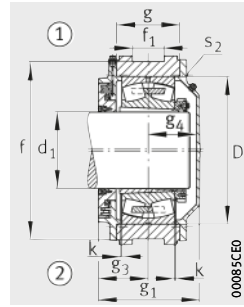

Guidance on both sides
Design A
Housing with Taconite seal

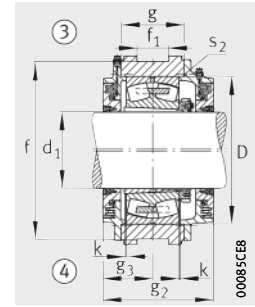

Guidance on both sides
Design B

								Spherical roller bearing and accessories		Housing	
D	k	g	g ₃	g ₄	t	s ₂	Quantity	Bearing	Adapter sleeve	Mass m ≈ kg	Designation
440	4	175	150,5	132	490	M20	8	23152...K	H3152X(-HG)	325	SPA3152...S
480	3	205	170	148	535	M20	8	23252...K	H2352X(-HG)	410	SPA3252...S
420	4	135	118	108	460	M16	8	23056...K	H3056(-HG)	310	SPA3056...S
500	4	206	180	151	555	M24	8	23256...K	H2356X(-HG)	520	SPA3256...S
500	4	190	170	143	555	M24	8	23160...K	H3160(-HG)	440	SPA3160...S
540	4	230	182	175	600	M24	8	23260...K	H3260(-HG)	620	SPA3260...S
540	4	210	186	161	590	M24	8	23164...K	H3164-HG	560	SPA3164...S
580	5	238	192	187	640	M24	8	23264...K	H3264-HG	810	SPA3264...S
580	5	220	183	178	640	M24	8	23168...K	H3168-HG	630	SPA3168...S
620	5	260	217	205	680	M30	8	23268...K	H3268-HG	920	SPA3268...S
650	5	267	216	209	710	M30	8	23272...K	H3272-HG	885	SPA3272...S
620	5	230	202	190	680	M30	8	23176...K	H3176-HG	700	SPA3176...S
680	5	295	232	244	745	M30	8	23276...K	H3276-HG	900	SPA3276...S
720	5	300	252	237	790	M30	8	23280...K	H3280-HG	1 600	SPA3280...S
760	5	315	255	240	835	M30	8	23284...K	H3284-HG	1 800	SPA3284...S



Take-up housings

SPA, unsplit
 For spherical roller bearings
 with tapered bore and
 adapter sleeve
 Stepped shaft

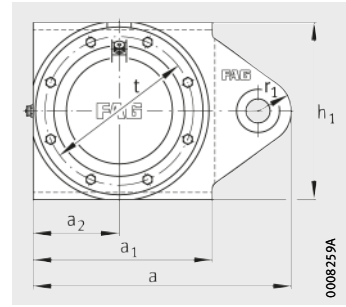
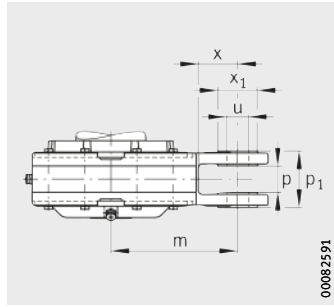

Dimension table - Dimensions in mm

Shaft		Housing Dimensions												
d ₁	d _c	h ₁	a	a ₁	a ₂	g ₁	g ₂	m	r ₁	x	x ₁	u	p	p ₁
	max.													
50	56	150	210	150	75	92,5	115	105	30	30	-	20	22	42
55	61	165	237,5	165	82,5	102,5	125	120	35	37,5	-	25	26	50
60	66	180	265	160	80	134	144	145	40	65	60	30	30	66
70	76	200	285	180	90	125	138	155	40	65	60	30	30	66
80	88	230	315	210	105	119	138	170	40	65	60	30	30	66
90	98	250	342,5	235	117,5	141	168	185	40	67,5	65	35	36	70
100	108	270	380	265	135	149,2	177,2	200	45	70	70	40	40	76
110	118	290	395	280	140	143	168	210	45	70	70	40	40	76
125	137	330	445	320	160	166	196	230	55	70	70	40	40	76
125	137	300	425	260	130	136	156	225	70	90	90	50	60	150
135	147	320	445	280	140	149	176	235	70	95	90	50	60	150
140	152	370	625	370	185	216	229	350	90	160	100	60	62	132
150	166	360	492,5	325	162,5	178	203	260	70	90	90	50	60	150
150	166	400	672,5	375	187,5	215	250	395	90	180	100	60	62	132
160	176	370	540	375	180	176	201	290	70	90	90	50	60	130
160	176	450	600	420	210	240	274	300	90	90	120	80	72	140
170	186	440	550	385	190	181	211	290	70	90	90	50	60	150
180	196	440	550	385	190	201	241	290	70	90	90	50	60	150
180	196	440	650	420	210	242	278	360	80	140	100	60	70	140
180	196	500	650	470	235	260	299	325	90	85	120	80	72	140
200	216	480	615	430	210	206	241	325	80	100	100	60	70	200
200	216	510	885	470	235	252	291	530	120	260	160	100	74	144
200	216	540	940	520	260	279	329	530	150	250	140	100	130	200
220	236	540	925	520	260	276	326	515	150	250	160	100	123	215
220	236	580	970	560	280	308	351	540	150	260	140	100	130	220

① Locating bearing AF; ② Non-locating bearing AL; ③ Locating bearing BF; ④ Non-locating bearing BL

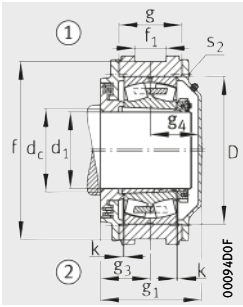

Guidance on both sides
Design A
Housing with labyrinth seal

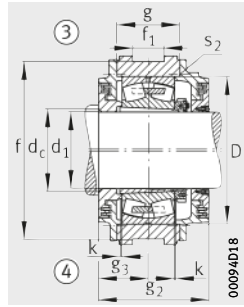

Guidance on both sides
Design B

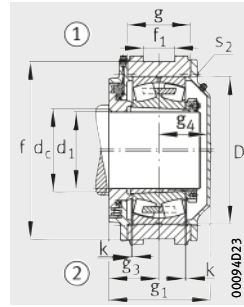

Guidance on both sides
Design A
Housing with Taconite seal

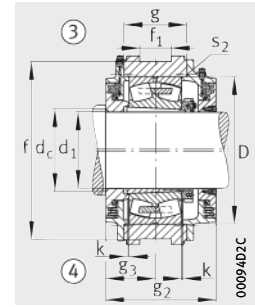

Guidance on both sides
Design B

										Spherical roller bearing and accessories		Housing	
f	f ₁	D	k	g	g ₃	g ₄	t	s ₂	Quantity	Bearing	Adapter sleeve	Mass m ≈ kg	Designation
135	34	100	2	45	52,5	35	130	M8	6	22211..-K	H311	9	SPA2211...S
150	35	110	2	55	57,5	40	135	M8	6	22212..-K	H312	12	SPA2212...S
155	53	120	2	78	72	56	135	M6	6	22213..-K	H313	16	SPA2213...S
175	53	140	2	78	69	49	155	M8	8	22216..-K	H316	25	SPA2216...S
200	53	160	2	70	60,5	52,5	185	M8	6	22218..-K	H318	22	SPA2218...S
220	40	180	2,5	65	78	57	205	M8	6	22220..-K	H320	26	SPA2220...S
240	53	200	2,5	73	82,6	60,6	230	M12	6	22222..-K	H322	32	SPA2222...S
260	53	215	2,5	77	74	61	245	M12	6	22224..-K	H3124	39	SPA2224...S
300	53	250	3	88	88	70	285	M16	6	22228..-K	H3128	58	SPA2228...S
270	45	210	3	70	68	61	240	M10	8	23028..-K	H3028	53	SPA3028...S
290	45	225	2	80	78	64	250	M12	8	23030..-K	H3030	65	SPA3030...S
340	75	270	3	116	108	100	300	M12	8	23132..-K	H3132(-HG)	120	SPA3132...S
330	65	260	2	102	89	81	285	M12	8	23034..-K	H3034(-HG)	90	SPA3034...S
370	65	280	3	120	115	92	330	M12	8	23134..-K	H3134(-HG)	131	SPA3134...S
340	60	280	3	100	88	80	310	M12	8	23036..-K	H3036(-HG)	85	SPA3036...S
410	93	320	3	138	127	105	370	M16	8	23236..-K	H2336(-HG)	158	SPA3236...S
400	65	290	3	105	93	80	325	M16	8	23038..-K	H3038(-HG)	129,5	SPA3038...S
400	65	310	3	105	105,5	87,5	340	M16	8	23040..-K	H3040(-HG)	180	SPA3040...S
410	100	340	3	135	124	108	380	M16	8	23140..-K	H3140(-HG)	165	SPA3140...S
460	103	360	4	158	138	114	420	M16	8	23240..-K	H2340(-HG)	260	SPA3240...S
440	65	340	3	115	103	95	375	M16	8	23044..-K	H3044X(-HG)	180	SPA3044...S
480	105	370	4	150	134	110	420	M16	8	23144..-K	H3144X(-HG)	280	SPA3144...S
500	90	400	4	175	147	122	445	M20	8	23244..-K	H2344X(-HG)	325	SPA3244...S
500	65	400	4	152	148	122	455	M20	8	23148..-K	H3148X(-HG)	330	SPA3148...S
545	95	440	4	190	158	140	510	M20	8	23248..-K	H2348X(-HG)	430	SPA3248...S



Take-up housings

SPA, unsplit
 For spherical roller bearings
 with tapered bore and
 adapter sleeve
 Stepped shaft

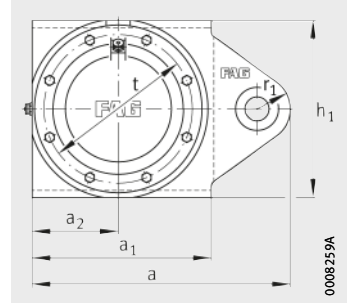
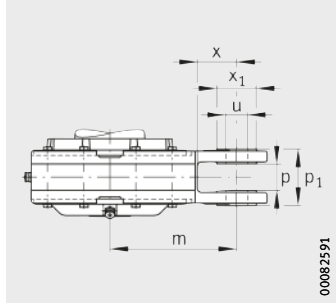

Dimension table (continued) · Dimensions in mm

Shaft		Housing Dimensions												
d ₁	d _c	h ₁	a	a ₁	a ₂	g ₁	g ₂	m	r ₁	x	x ₁	u	p	p ₁
	max.													
240	256	540	910	500	245	226	261	515	150	250	140	100	123	215
240	256	570	990	550	275	291	336	565	150	270	160	100	135	225
240	256	610	1 063	596	298	330	370	615	150	300	140	100	173	240
260	280	540	910	500	245	236	281	515	150	250	140	100	123	215
260	280	650	1 095	630	315	343	400	630	150	220	140	100	173	240
280	300	650	1 115	630	315	327	385	650	150	310	140	100	170	270
280	300	690	1 200	680	340	369	404	680	180	310	140	100	190	270
300	320	670	1 140	665	340	359	412	650	150	310	175	100	170	240
300	320	710	1 280	710	355	391	439	725	200	275	170	110	213	300
320	344	740	1 290	740	370	373	421	720	200	310	180	120	180	300
320	344	740	1 335	735	385	434	489	750	200	310	170	110	213	300
340	364	830	1 390	800	400	437	497	765	225	310	190	130	213	330
360	384	790	1 325	750	375	404	459	750	200	320	170	110	200	300
360	384	820	1 385	810	405	489	529	780	200	305	170	110	213	300
380	404	960	1 460	880	440	504	569	820	200	350	170	110	180	300
400	430	960	1 488	925	465	510	575	825	200	350	170	110	180	300

① Locating bearing AF; ② Non-locating bearing AL; ③ Locating bearing BF; ④ Non-locating bearing BL

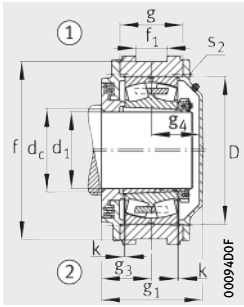

Guidance on both sides
Design A
Housing with labyrinth seal

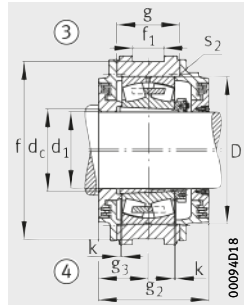

Guidance on both sides
Design B

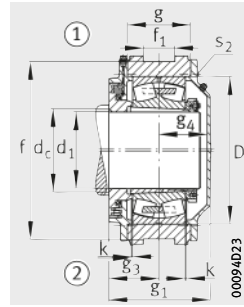

Guidance on both sides
Design A
Housing with Taconite seal

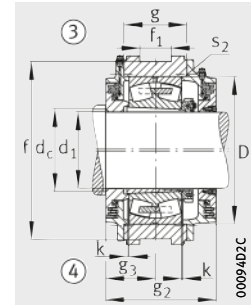

Guidance on both sides
Design B

										Spherical roller bearing and accessories		Housing	
f	f ₁	D	k	g	g ₃	g ₄	t	s ₂	Quantity	Bearing	Adapter sleeve	Mass m ≈ kg	Designation
540	80	440	4	175	150,5	132	490	M20	8	23152..-K	H3152X(-HG)	325	SPA3152...S
570	103	480	3	205	170	148	535	M20	8	23252..-K	H2352X(-HG)	410	SPA3252...S
500	65	420	4	135	118	108	460	M16	8	23056..-K	H3056(-HG)	310	SPA3056...S
610	123	500	4	206	180	151	555	M24	8	23256..-K	H2356X(-HG)	520	SPA3256...S
610	130	500	4	190	170	143	555	M24	8	23160..-K	H3160(-HG)	440	SPA3160...S
650	115	540	4	230	182	175	600	M24	8	23260..-K	H3260(-HG)	620	SPA3260...S
630	123	540	4	210	186	161	590	M24	8	23164..-K	H3164-HG	560	SPA3164...S
670	123	580	5	238	192	187	640	M24	8	23264..-K	H3264-HG	810	SPA3264...S
700	150	580	5	220	183	178	640	M24	8	23168..-K	H3168-HG	630	SPA3168...S
700	123	620	5	260	217	205	680	M30	8	23268..-K	H3268-HG	920	SPA3268...S
790	123	650	5	267	216	209	710	M30	8	23272..-K	H3272-HG	885	SPA3272...S
740	120	620	5	230	202	190	680	M30	8	23176..-K	H3176-HG	700	SPA3176...S
780	123	680	5	295	232	244	745	M30	8	23276..-K	H3276-HG	900	SPA3276...S
900	190	720	5	300	252	237	790	M30	8	23280..-K	H3280-HG	1 600	SPA3280...S
900	190	760	5	315	255	240	835	M30	8	23284..-K	H3284-HG	1 800	SPA3284...S





Flanged housings

F112

F5



Flanged housings

Flanged housings F112 356

Flanged housings F112 can be used in a wide variety of applications, for example in general machine building. In many cases, the flange integrated in the housing represents the ideal interface with the machine or installation.

The housings, which are made from flake graphite cast iron, are designed for grease lubrication.

The bearings are always fitted in this housing such that they act as locating bearings. Suitable bearings are self-aligning ball bearings 112 with an extended inner ring.

Flanged housings F5 364

Flanged housings F5 can be used in a wide variety of applications, for example in general machine building. In many cases, the flange integrated in the housing represents the ideal interface with the machine or installation.

The housings are designed for grease lubrication. The standard housing material is flake graphite cast iron, while a design made from spheroidal graphite cast iron is also available. Depending on the size, the housing is of a triangular or square basic shape with three or four fixing holes.

Suitable bearings are self-aligning ball bearings, barrel roller bearings and spherical roller bearings with a tapered bore that are located on the shaft using adapter sleeves.

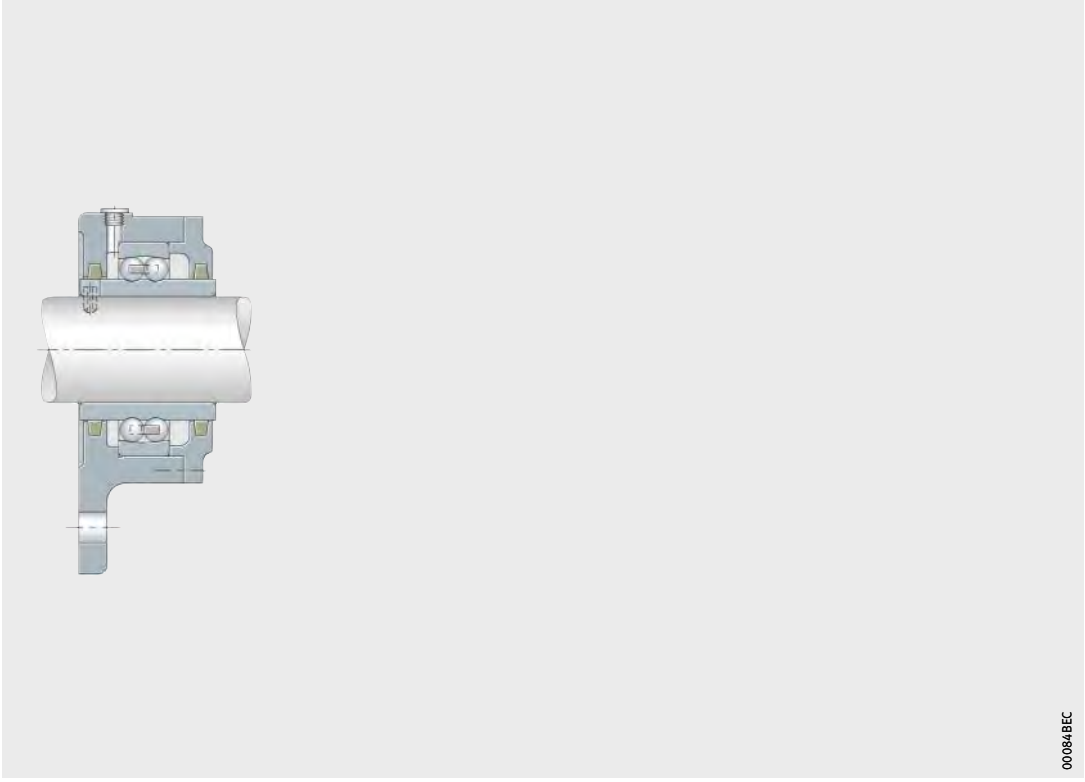

00084BEC

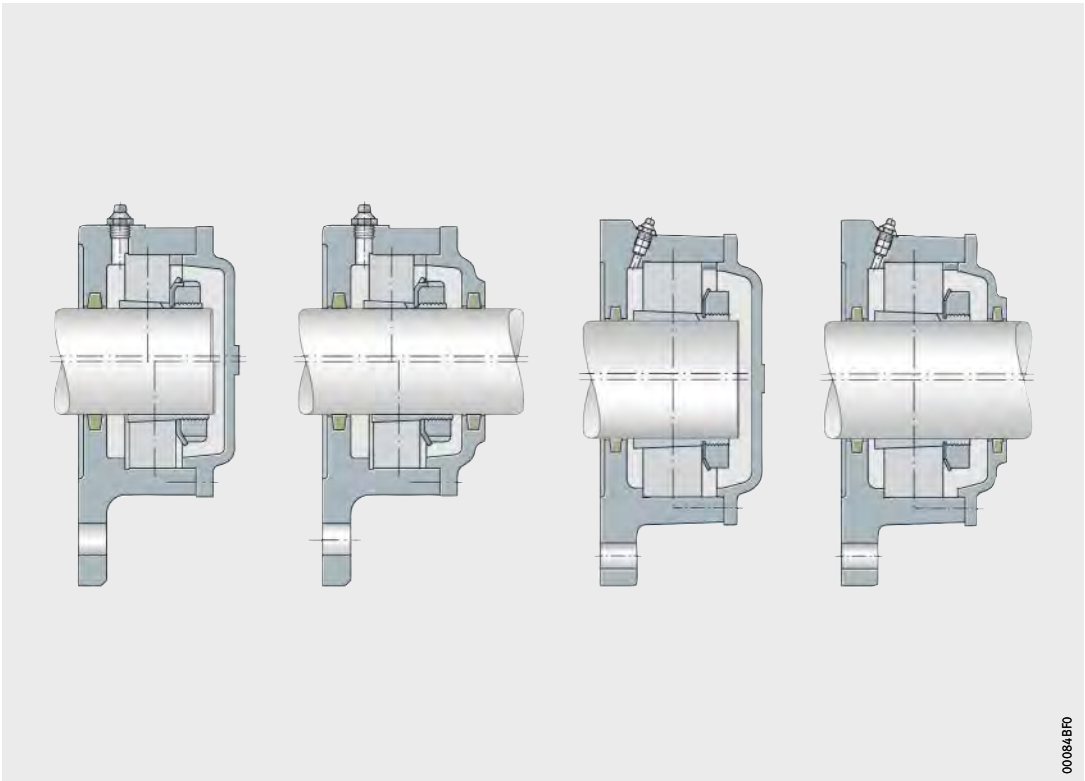

00084BF0

FAG



Flanged housings F112

Flanged housings F112

	Page
Product overview	Flanged housings F112..... 358
Features	Suitable bearings 359
	Housing material and anti-corrosion protection..... 359
	Locating bearings 359
	Seals..... 359
	Housing configurations..... 360
	Lubrication 360
	Designation structure 361
	Ordering example 361
Design and safety guidelines	Flange screws..... 362
Accuracy 362
Dimension tables	Flanged housings F112, unsplit, for self-aligning ball bearings with extended inner ring..... 363



Product overview Flanged housings F112

Flanged housings

F112



Flanged housings F112

Features Flanged housings F112 can be used in a wide variety of applications, for example in machine structures and support structures.

Suitable bearings The dimensions of flanged housings F112 are matched to self-aligning ball bearings 112 with an extended inner ring, see table. The range of shaft diameters is between 20 mm and 60 mm.

Bearing type and sizes

Bearing type	Size
Self-aligning ball bearings ■ with cylindrical bore and extended inner ring	11204 to 11212

Housing material and anti-corrosion protection

The housing bodies are made from flake graphite cast iron. All outer surfaces not machined by chip-forming methods have a universal paint coating (colour RAL 7031, bluish-grey). The coating can be finished using all synthetic resin, polyurethane, acrylic, epoxy resin, chlorinated rubber, nitrocellulose and acid-hardening hammer tone finishes.

Inner and outer surfaces machined by chip-forming methods are provided with anti-corrosion protection that can be easily removed. It is recommended that only volatile solvents and lint-free cloths should be used.

Locating bearings

In flanged housings F112, the self-aligning ball bearing is clamped between the abutment shoulder in the housing and the cover. As a result, the bearing acts as a locating bearing.

Seals

Flanged housings F112 are sealed by means of felt seals, *Figure 1*. The felt seals allow shaft misalignment of up to $0,5^\circ$ in both directions and are suitable for grease lubrication. The oil-soaked felt strips must be inserted in the associated slots in the housing.

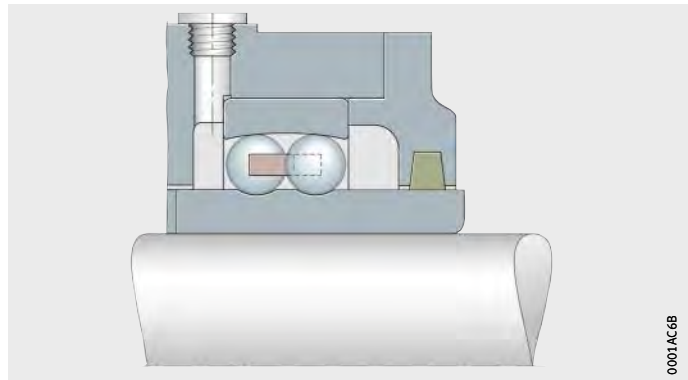

Figure 1
Felt seal for flanged housings F112

Flanged housings F112

Housing configuration

Flanged housings F112 are supplied in a uniform housing configuration, *Figure 2*.

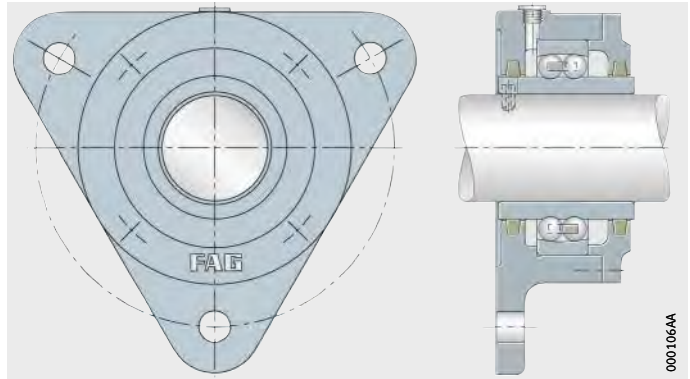

Figure 2
Flanged housing F112
for self-aligning ball bearings
with extended inner ring

Lubrication

Flanged housings F112 are designed for grease lubrication.

Relubrication

The top of the housing has a threaded hole M10×1. In the delivered condition, this is closed off using a plastic stopper. For relubrication, a taper type or button type lubrication nipple can be screwed into place here. In the case of flanged housings F112, the lubrication nipples are not included in the scope of delivery.

Designation structure

The designation structure for flanged housings F112 is shown in the table and *Figure 3*.

Designation structure of flanged housings F112

Feature	Code	Description
① Series	F112	Flanged housings F112
② Bore code of bearing	05	Bore diameter (5 · 5) mm = 25 mm



Figure 3
Designation structure of flanged housings F112, example

Ordering example

When ordering a flanged housing F112, the designation indicates the bore diameter of the appropriate self-aligning ball bearing. The rolling bearing must be ordered separately.

The ordering example shows the construction of the order for a selected housing and the appropriate bearing. The allocation of housings and bearings for all housing sizes is shown in the dimension table.

The felt strips for sealing the housing are included in the scope of delivery and need not be ordered separately.

Example 1

Flanged housing F112, for self-aligning ball bearings 11204-TVH.

Order

1 flanged housing F11204

1 self-aligning ball bearing 11204-TVH



Flanged housings F112

Design and safety guidelines

Flange screws

Flange screws are used to screw mount the housing flange to a mating surface. They are not included in the scope of delivery of the housings.

The appropriate screw size for each housing is stated, see dimension table.

The associated tightening torques are stated for screws with a metric thread in accordance with DIN 13, DIN 962 and DIN ISO 965-2, see table, page 42. The values correspond to those of the foot screws for plummer block housings.

Accuracy

The bearing seat in flanged housings F112 is machined to the tolerance class H7.

By agreement, the housings can also be supplied with other tolerance classes for the bearing seat, see section Tolerance class of bearing seat, page 47.

Flanged housings

F112, unsplit
For self-aligning ball bearings with extended inner ring

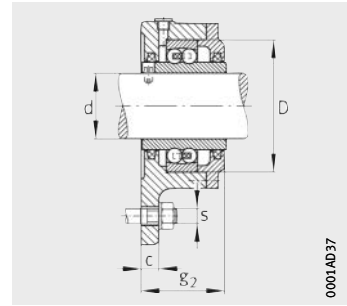
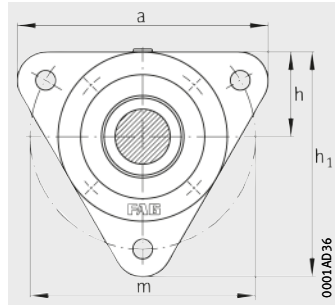

Dimension table · Dimensions in mm

Shaft d	Housing Dimensions									Self-aligning ball bearing and accessories			Housing	
	h	h ₁	c	a	m	s		D	g ₂	Bearing	Felt strip ¹⁾ (length 1000 mm)		Mass m ≈ kg	Designation
						mm	inch				Designation	Quantity		
20	35	92	10	105	90	M10	3/8	47	42	11204	STRS153401-1-5X4-F2	1	0,7	F11204
25	38	100	10	110	96	M10	3/8	52	46	11205	STRS153401-1-5X4-F2	1	0,8	F11205
30	44	117	12	130	116	M10	3/8	62	49	11206	STRS153401-1-5X4-F2	1	1,4	F11206
35	48,5	129,5	12	145	130	M12	1/2	72	54	11207	STRS153401-1-5X4-F2	1	1,8	F11207
40	54	143	12	160	140	M12	1/2	80	60	11208	STRS153401-1-5X4-F2	1	2,2	F11208
45	60	160	15	180	160	M12	1/2	85	62,5	11209	STRS153401-1-5X4-F2	1	3,1	F11209
50	60	160	15	180	160	M12	1/2	90	62,5	11210	STRS153401-1-5X4-F2	1	3	F11210
55	65	166	16	180	160	M12	1/2	100	63,5	11211	STRS153401-1-5X4-F2	1	3,2	F11211
60	70	177	16	191	170	M12	1/2	110	65,5	11212	STRS153401-1-5X4-F2	1	3,5	F11212

1) The felt strips are supplied by the metre and cut to the appropriate length on site.





Flanged housings F5

Flanged housings F5

	Page
Product overview	Flanged housings F5 366
Features	Suitable bearings 368
	Housing materials and anti-corrosion protection 368
	Locating and non-locating bearings 368
	Seals and covers 368
	Housing configurations..... 369
	Lubrication 370
	Designation structure 371
	Ordering examples 372
Design and safety guidelines	Flange screws..... 373
Accuracy 373
Dimension tables	Flanged housings F5, unsplit, for bearings with tapered bore and adapter sleeve 374



Product overview Flanged housings F5

Flanged housings

Closed on one side, with cover

F5...-A
(F505-A to F513-A)



F5...-A
(F515-A to F522-A)



For continuous shaft

F5...-B
(F505-B to F513-B)



F5..-B
(F515-B to F522-B)

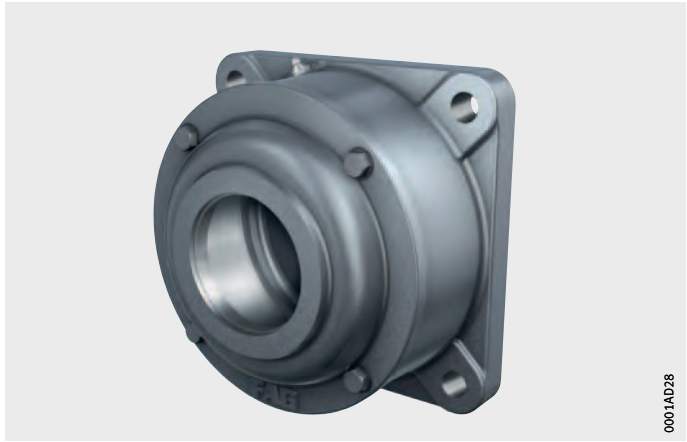

Accessories

Locating rings

For housings F505 to F513
For housings F515 to F522

FE



FRM



Flanged housings F5

Features

Flanged housings F5 can be used in a wide variety of applications.

Suitable bearings

Flanged housings F5 are intended for fitting with self-aligning ball bearings, barrel roller bearings and spherical roller bearings with a tapered bore that are located on the shaft using adapter sleeves, see table. The range of shaft diameters is between 20 mm and 100 mm.

Bearing types and sizes

Bearing type	Size
Spherical roller bearings ■ with tapered bore and adapter sleeve	22205..-K to 22222..-K
Self-aligning ball bearings ■ with tapered bore and adapter sleeve	1205-K to 1222-K 2205-K to 2222-K
Barrel roller bearings ■ with tapered bore and adapter sleeve	20205-K to 20222-K

Housing materials and anti-corrosion protection

The standard material for the housing bodies is flake graphite cast iron (suffix L). By agreement, housing bodies made from spheroidal graphite cast iron (suffix D) are available.

All outer surfaces not machined by chip-forming methods have a universal paint coating (colour RAL 7031, bluish-grey). The coating can be finished using all synthetic resin, polyurethane, acrylic, epoxy resin, chlorinated rubber, nitrocellulose and acid-hardening hammer tone finishes.

Inner and outer surfaces machined by chip-forming methods are provided with anti-corrosion protection that can be easily removed. It is recommended that only volatile solvents and lint-free cloths should be used.

Locating and non-locating bearings

The bearing seats in the housing are machined such that the bearings are movable and can thus function as non-locating bearings. Locating bearing arrangements can be achieved by the insertion of locating rings. For housings F505 to F513, locating rings FE are used, while for housings F515 to F522, locating rings FRM are used. The quantity of locating rings required is 1 or 2, see dimension table. Two rings are inserted on both sides of the bearing, a single ring is inserted on the side with the adapter sleeve nut.

Locating rings must be ordered separately.

Seals and covers

Flanged housings F5 of design A are intended for the bearing arrangements of shaft ends. One side is closed by a cover and the other side is sealed against the shaft. Design B is intended for continuous shafts, in which case the housing is sealed against the shaft on both sides.

Flanged housings F5 are sealed by means of felt seals, *Figure 1*, page 369. The felt seals allow shaft misalignment of up to 0,5° in both directions and are suitable for grease lubrication.

The oil-soaked felt strips must be inserted in the associated slots in the housing.

Figure 1
Felt seal for flanged housings F5

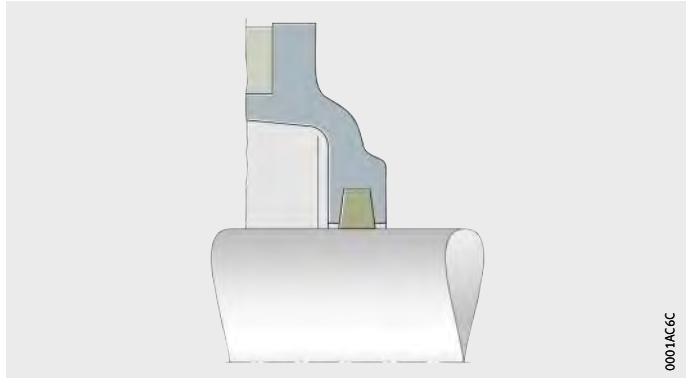

Housing configurations

In the case of flanged housings F5, various housing configurations are possible that are described by means of the designation, *Figure 2 to Figure 5*, page 370. For a locating bearing arrangement, the locating rings must be ordered separately.

The following features can be varied in the housing configuration:

- continuous shaft or a housing closed on one side
- selection of the housing design as a function of the bearing width
- design of the bearing arrangement as a locating bearing arrangement or a non-locating bearing arrangement.

The basic shape of the housings varies with the size:

- triangular basic shape with 3 cover screws in the flanged housings F505, F506 and F508, *Figure 2 to Figure 3*, page 370
- triangular basic shape with 4 cover screws in the flanged housings F507, F509 to F513
- square basic shape with 4 cover screws in the flanged housings F515 to F522, *Figure 4*, page 370 to *Figure 5*, page 370.

- ① Locating bearing F5...-A, F5...-WA
- ② Non-locating bearing F5...-A, F5...-WA

Figure 2
Flanged housings F505, F506 and F508, for bearings with tapered bore and adapter sleeve, design A

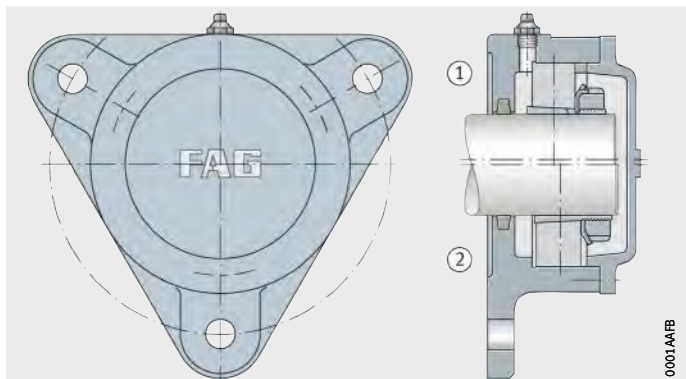

Flanged housings F5

- ① Locating bearing F5...-B, F5...-WB
- ② Non-locating bearing F5...-B, F5...-WB

Figure 3
Flanged housings F507,
F509 to F513,
for bearings with tapered bore
and adapter sleeve,
design B

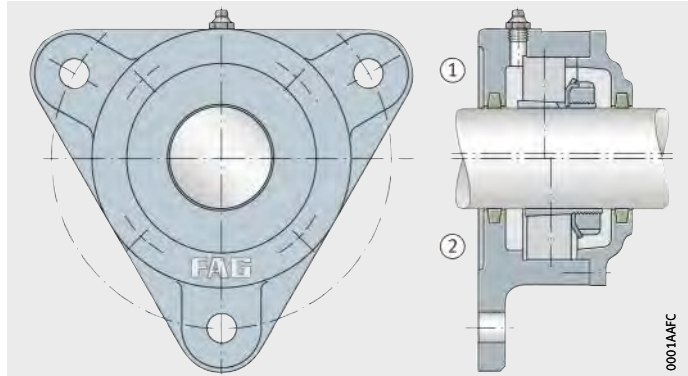

- ① Locating bearing F5...-A, F5...-WA
- ② Non-locating bearing F5...-A, F5...-WA

Figure 4
Flanged housings F515 to F522,
for bearings with tapered bore
and adapter sleeve,
design A

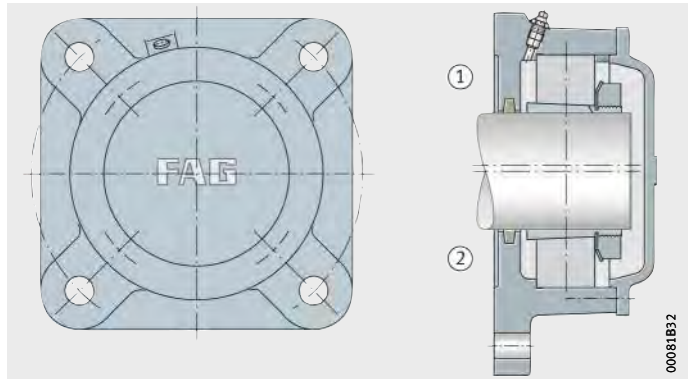

- ① Locating bearing F5...-B, F5...-WB
- ② Non-locating bearing F5...-B, F5...-WB

Figure 5
Flanged housings F515 to F522,
for bearings with tapered bore
and adapter sleeve,
design B

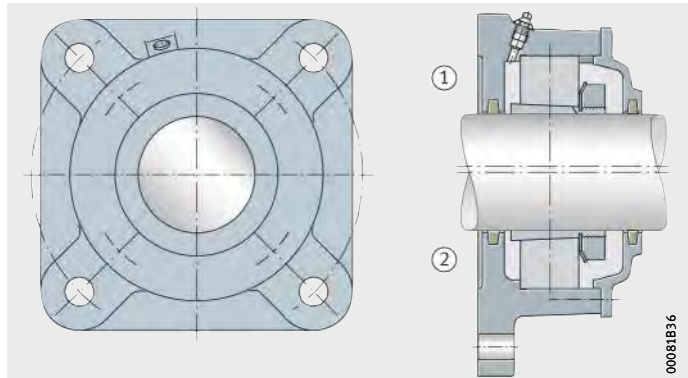

Lubrication

Flanged housings F5 are designed for grease lubrication.

Relubrication

For relubrication, a taper type lubrication nipple to DIN 71412-AM10×1 is screwed into the top of the housing.

Designation structure

The designation structure for flanged housings F5 and accessories is shown in the tables and *Figure 6* to *Figure 7*.

Designation structure of flanged housings F5

Feature	Code	Description
① Series	F5	Flanged housings F5
② Bore code of bearing	10	Bore diameter (10 · 5) mm = 50 mm
③ Housing design	A	Closed on one side
	WA	Closed on one side, wider bearing
	B	Continuous shaft
	WB	Continuous shaft, wider bearing
④ Housing material	L	Flake graphite cast iron (standard)
	D	Spheroidal graphite cast iron



Figure 6
Designation structure of flanged housings F5, example

Designation structure of locating rings

Feature	Code	Description
① Series	FE	Locating ring (for F505 to F513)
	FRM	Locating ring (for F515 to F522)
② Outside diameter	110	Outside diameter 110 mm
③ Width	2	Width 2 mm

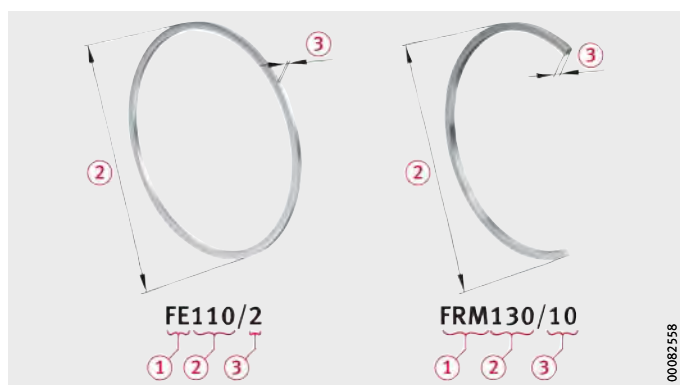

Figure 7
Designation structure of locating rings, example

Flanged housings F5

Ordering examples

When ordering a flanged housing F5, the designation contains indications of the size of the bearing as well as the design and material of the housing. Locating rings must be ordered separately. The rolling bearing and the adapter sleeve must be ordered separately.

Flanged housings F5 with a bearing fitted give non-locating bearing arrangements. These can be converted into locating bearing arrangements through the additional insertion of locating rings FE or FRM.

The ordering examples show the construction of orders for selected housing combinations and the appropriate bearings. The allocation of housings, bearings and accessories for all housing sizes is shown in the dimension table.

The felt strips for sealing the housing are included in the scope of delivery and need not be ordered separately.

- Example 1** Flanged housing F5 made from flake graphite cast iron, closed on one side, self-aligning ball bearing 2207-K-TVH-C3 as locating bearing, location by means of adapter sleeve.
- | | | |
|-------|------------------------------|---------------|
| Order | 1 flanged housing | F507-WA-L |
| | 1 self-aligning ball bearing | 2207-K-TVH-C3 |
| | 1 adapter sleeve | H307 |
| | 1 locating ring | FE72/2 |
- Example 2** Flanged housing F5 made from flake graphite cast iron, closed on one side, self-aligning ball bearing 1220-K-M-C3 as locating bearing, location by means of adapter sleeve.
- | | | |
|-------|------------------------------|-------------|
| Order | 1 flanged housing | F520-A-L |
| | 1 self-aligning ball bearing | 1220-K-M-C3 |
| | 1 adapter sleeve | H220 |
| | 1 locating ring | FRM180/10 |
| | 1 locating ring | FRM180/12 |
- Example 3** Flanged housing F5 made from flake graphite cast iron, for continuous shaft, spherical roller bearing 22222-E1-K as non-locating bearing, location using adapter sleeve.
- | | | |
|-------|----------------------------|------------|
| Order | 1 flanged housing | F522-WB-L |
| | 1 spherical roller bearing | 22222-E1-K |
| | 1 adapter sleeve | H322 |

Design and safety guidelines

Flange screws

Flange screws are used to screw mount the housing flange to a mating surface. They are not included in the scope of delivery of the housings.

The appropriate screw size for each housing is stated, see dimension table.

The associated tightening torques are stated for screws with a metric thread in accordance with DIN 13, DIN 962 and DIN ISO 965-2, see table, page 42. The values correspond to those of the foot screws for plummer block housings.

Accuracy

The bearing seat in flanged housings F5 is machined to the tolerance class H7.

By agreement, the housings can also be supplied with other tolerance classes for the bearing seat, see section Tolerance class of bearing seat, page 47.



Flanged housings

F5, unsplit
For bearings with tapered bore and adapter sleeve

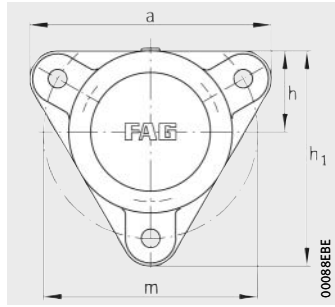

F505, F506, F508

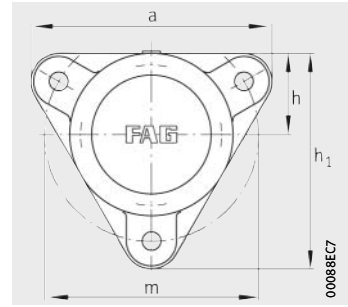

F507, F509 to F513

Dimension table - Dimensions in mm

Shaft d_1	Housing Dimensions											
	h	h_1	c	a	m	s		D	g_1	g_2	g_3	g_4
						mm	inch					
20	38	100	10	110	96	M10	3/8	52	50	–	4	16
20	38	100	10	110	96	M10	3/8	52	–	55	–	16
20	38	100	10	110	96	M10	3/8	52	50	–	4	14,5
20	38	100	10	110	96	M10	3/8	52	–	55	–	14,5
25	44	117	12	130	116	M10	3/8	62	55	–	4	18
25	44	117	12	130	116	M10	3/8	62	–	57	–	18
25	44	117	12	130	116	M10	3/8	62	55	–	4	16
25	44	117	12	130	116	M10	3/8	62	–	57	–	16
30	48,5	130	12	145	130	M12	1/2	72	57	–	5	17
30	48,5	130	12	145	130	M12	1/2	72	–	60	–	17
30	48,5	130	12	145	130	M12	1/2	72	63	–	5	17
30	48,5	130	12	145	130	M12	1/2	72	–	66	–	17
35	54	143	12	160	140	M12	1/2	80	65	–	5	22
35	54	143	12	160	140	M12	1/2	80	–	66	–	22
35	54	143	12	160	140	M12	1/2	80	70	–	5	22
35	54	143	12	160	140	M12	1/2	80	–	71	–	22
40	60	160	15	180	160	M12	1/2	85	65	–	5	22
40	60	160	15	180	160	M12	1/2	85	–	70	–	22
40	60	160	15	180	160	M12	1/2	85	69	–	5	22
40	60	160	15	180	160	M12	1/2	85	–	74	–	22
45	60	160	15	180	160	M12	1/2	90	65	–	5	20
45	60	160	15	180	160	M12	1/2	90	–	70	–	20
45	60	160	15	180	160	M12	1/2	90	71	–	5	23
45	60	160	15	180	160	M12	1/2	90	–	76	–	23
50	65	170	16	190	170	M12	1/2	100	71	–	6	23
50	65	170	16	190	170	M12	1/2	100	–	76	–	23
50	65	170	16	190	170	M12	1/2	100	77	–	6	25
50	65	170	16	190	170	M12	1/2	100	–	82	–	25
55	70	185	16	206	180	M12	1/2	110	73	–	6	24
55	70	185	16	206	180	M12	1/2	110	–	78	–	24
55	70	185	16	206	180	M12	1/2	110	79	–	6	24
55	70	185	16	206	180	M12	1/2	110	–	84	–	24

① Locating bearing; ② Non-locating bearing

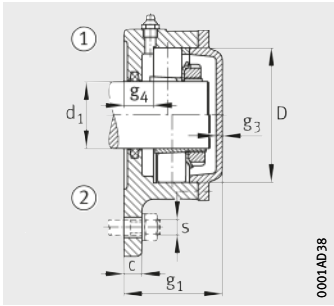

Design A

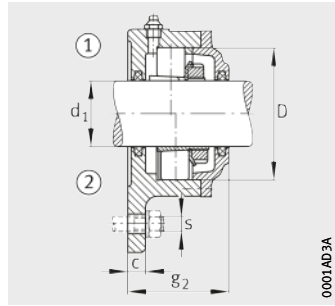

Design B

Bearing and accessories							Housing	
Bearing	Adapter sleeve	Locating ring	Felt strip		Mass m ≈ kg	Designation		
			Quantity	a×b×l mm				
1205-K	20205-K	H205	FE52/2	1	5×4×90	1	1,2	F505-A-L
1205-K	20205-K	H205	FE52/2	1	5×4×90	2	1,2	F505-B-L
2205-K	22205..-K	H305	FE52/2	1	5×4×90	1	1,2	F505-WA-L
2205-K	22205..-K	H305	FE52/2	1	5×4×90	2	1,2	F505-WB-L
1206-K	20206-K	H206	FE62/2	1	6×5×115	1	1,6	F506-A-L
1206-K	20206-K	H206	FE62/2	1	6×5×115	2	1,6	F506-B-L
2206-K	22206..-K	H306	FE62/2	1	6×5×115	1	1,6	F506-WA-L
2206-K	22206..-K	H306	FE62/2	1	6×5×115	2	1,6	F506-WB-L
1207-K	20207-K	H207	FE72/2	1	6×5×130	1	2	F507-A-L
1207-K	20207-K	H207	FE72/2	1	6×5×130	2	2	F507-B-L
2207-K	22207..-K	H307	FE72/2	1	6×5×130	1	2	F507-WA-L
2207-K	22207..-K	H307	FE72/2	1	6×5×130	2	2	F507-WB-L
1208-K	20208-K	H208	FE80/2	1	6×5×145	1	2,5	F508-A-L
1208-K	20208-K	H208	FE80/2	1	6×5×145	2	2,5	F508-B-L
2208-K	22208..-K	H308	FE80/2	1	6×5×145	1	2,5	F508-WA-L
2208-K	22208..-K	H308	FE80/2	1	6×5×145	2	2,5	F508-WB-L
1209-K	20209-K	H209	FE85/2	1	6×5×160	1	3,6	F509-A-L
1209-K	20209-K	H209	FE85/2	1	6×5×160	2	3,6	F509-B-L
2209-K	22209..-K	H309	FE85/2	1	6×5×160	1	3,6	F509-WA-L
2209-K	22209..-K	H309	FE85/2	1	6×5×160	2	3,6	F509-WB-L
1210-K	20210-K	H210	FE90/2	1	6×5×175	1	3,8	F510-A-L
1210-K	20210-K	H210	FE90/2	1	6×5×175	2	3,8	F510-B-L
2210-K	22210..-K	H310	FE90/2	1	6×5×175	1	3,8	F510-WA-L
2210-K	22210..-K	H310	FE90/2	1	6×5×175	2	3,8	F510-WB-L
1211-K	20211-K	H211	FE100/2	1	8×6,5×200	1	4,1	F511-A-L
1211-K	20211-K	H211	FE100/2	1	8×6,5×200	2	4,1	F511-B-L
2211-K	22211..-K	H311	FE100/2	1	8×6,5×200	1	4,1	F511-WA-L
2211-K	22211..-K	H311	FE100/2	1	8×6,5×200	2	4,1	F511-WB-L
1212-K	20212-K	H212	FE110/2	1	8×6,5×215	1	4,6	F512-A-L
1212-K	20212-K	H212	FE110/2	1	8×6,5×215	2	4,6	F512-B-L
2212-K	22212..-K	H312	FE110/2	1	8×6,5×215	1	4,6	F512-WA-L
2212-K	22212..-K	H312	FE110/2	1	8×6,5×215	2	4,6	F512-WB-L



Flanged housings

F5, unsplit
For bearings with tapered bore and adapter sleeve

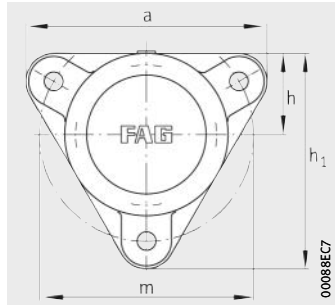

F513

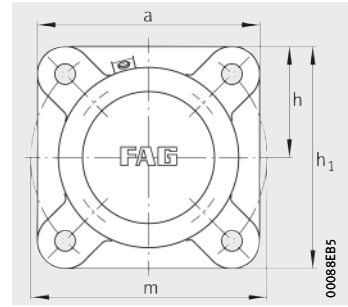

F515 to F522

Dimension table (continued) · Dimensions in mm

Shaft d_1	Housing Dimensions											
	h	h_1	c	a	m	s		D	g_1	g_2	g_3	g_4
						mm	inch					
60	75	198	16	219	190	M12	1/2	120	75	–	6	24
60	75	198	16	219	190	M12	1/2	120	–	79	–	24
60	75	198	16	219	190	M12	1/2	120	83	–	6	24
60	75	198	16	219	190	M12	1/2	120	–	87	–	24
65	95	190	25	190	215	M16	5/8	130	97	–	6	30
65	95	190	25	190	215	M16	5/8	130	97	–	6	30
65	95	190	25	190	215	M16	5/8	130	–	104	–	30
65	95	190	25	190	215	M16	5/8	130	–	104	–	30
70	98	196	25	196	215	M16	5/8	140	101	–	6	32
70	98	196	25	196	215	M16	5/8	140	101	–	6	32
70	98	196	25	196	215	M16	5/8	140	–	110	–	32
70	98	196	25	196	215	M16	5/8	140	–	110	–	32
75	105	210	25	210	240	M16	5/8	150	106	–	7	31
75	105	210	25	210	240	M16	5/8	150	106	–	7	31
75	105	210	25	210	240	M16	5/8	150	–	114	–	31
75	105	210	25	210	240	M16	5/8	150	–	114	–	31
80	105	210	25	210	240	M16	5/8	160	110	–	7	29
80	105	210	25	210	240	M16	5/8	160	110	–	7	29
80	105	210	25	210	240	M16	5/8	160	–	118	–	29
80	105	210	25	210	240	M16	5/8	160	–	118	–	29
90	125	250	30	250	280	M20	3/4	180	119	–	8	29
90	125	250	30	250	280	M20	3/4	180	119	–	8	29
90	125	250	30	250	280	M20	3/4	180	–	127	–	29
90	125	250	30	250	280	M20	3/4	180	–	127	–	29
100	135	270	30	270	310	M20	3/4	200	128	–	8	30
100	135	270	30	270	310	M20	3/4	200	–	137	–	30
100	135	270	30	270	310	M20	3/4	200	128	–	8	30
100	135	270	30	270	310	M20	3/4	200	–	137	–	30

① Locating bearing; ② Non-locating bearing

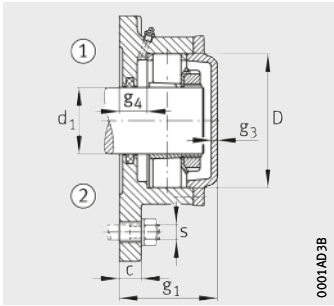

Design A

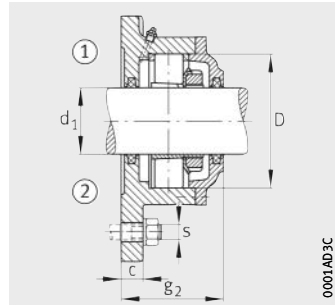

Design B

Bearing and accessories

Housing

Bearing		Adapter sleeve	Locating ring		Felt strip		Mass m ≈ kg	Designation
				Quantity	a×b×l mm	Quantity		
1213-K	20213-K	H213	FE120/2	1	8×6,5×230	1	5,4	F513-A-L
1213-K	20213-K	H213	FE120/2	1	8×6,5×230	2	5,4	F513-B-L
2213-K	22213..-K	H313	FE120/2	1	8×6,5×230	1	5,4	F513-WA-L
2213-K	22213..-K	H313	FE120/2	1	8×6,5×230	2	5,4	F513-WB-L
1215-K	20215-K	H215	FRM130/8	2	8×6,5×245	1	9,5	F515-A-L
2215-K	22215..-K	H315	FRM130/10	1	8×6,5×245	1	9,5	F515-A-L
1215-K	20215-K	H215	FRM130/8	2	8×6,5×245	2	9,5	F515-B-L
2215-K	22215..-K	H315	FRM130/10	1	8×6,5×245	2	9,5	F515-B-L
1216-K	20216-K	H216	FRM140/8,5	2	9×7,5×270	1	10	F516-A-L
2216-K	22216..-K	H316	FRM140/10	1	9×7,5×270	1	10	F516-A-L
1216-K	20216-K	H216	FRM140/8,5	2	9×7,5×270	2	10	F516-B-L
2216-K	22216..-K	H316	FRM140/10	1	9×7,5×270	2	10	F516-B-L
1217-K	20217-K	H217	FRM150/9	2	9×7,5×285	1	12	F517-A-L
2217-K	22217..-K	H317	FRM150/10	1	9×7,5×285	1	12	F517-A-L
1217-K	20217-K	H217	FRM150/9	2	9×7,5×285	2	12	F517-B-L
2217-K	22217..-K	H317	FRM150/10	1	9×7,5×285	2	12	F517-B-L
1218-K	20218-K	H218	FRM160/10	2	9×7,5×300	1	13	F518-A-L
2218-K	22218..-K	H318	FRM160/10	1	9×7,5×300	1	13	F518-A-L
1218-K	20218-K	H218	FRM160/10	2	9×7,5×300	2	13	F518-B-L
2218-K	22218..-K	H318	FRM160/10	1	9×7,5×300	2	13	F518-B-L
1220-K	20220-K	H220	FRM180/10+FRM180/12	1	10×8,5×335	1	18	F520-A-L
2220-K	22220..-K	H320	FRM180/10	1	10×8,5×335	1	18	F520-A-L
1220-K	20220-K	H220	FRM180/10+FRM180/12	1	10×8,5×335	2	18	F520-B-L
2220-K	22220..-K	H320	FRM180/10	1	10×8,5×335	2	18	F520-B-L
1222-K	20222-K	H222	FRM200/13,5	2	12×10×375	1	22	F522-A-L
2222-K	22222..-K	H222	FRM200/13,5	2	12×10×375	2	22	F522-B-L
2222-K	22222..-K	H322	FRM200/10	1	12×10×375	1	22	F522-WA-L
2222-K	22222..-K	H322	FRM200/10	1	12×10×375	2	22	F522-WB-L



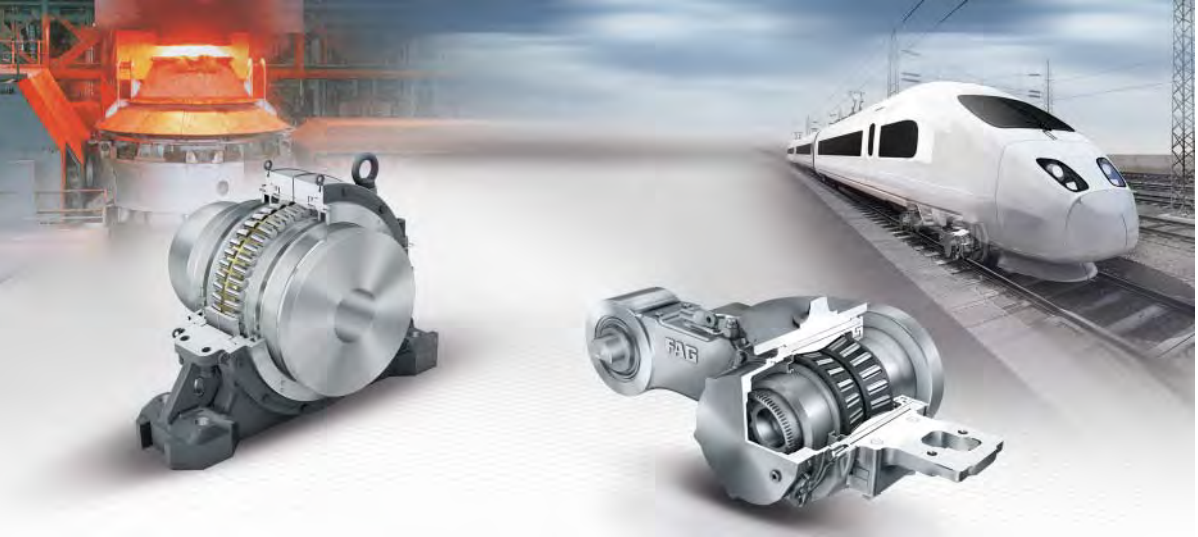

Housings for specific industrial and railway applications



FAG



Housings for specific industrial applications

Housings for specific industrial applications

	Page
Products and services	
Customer-specific solutions.....	382
Portfolio	382
Application examples	
Plummer block housings for the paper industry.....	384
Water-cooled plummer block housings for continuous casting machines	385
Twin block housings for rotary kilns in cement production	386
Converter housings for steel production	387
Flanged housing units for large electrical machinery.....	388



Housings for specific industrial applications

Products and services

In order to fulfil the demand for bearing housings in special applications and unconventional operating conditions, Schaeffler offers an extensive range of products and services.

Customer-specific solutions

Demanding applications in the industrial field often place special requirements on the bearing housings. These requirements cannot always be fulfilled by the use of standard housings. In these cases, the optimum solution can be facilitated by the use of special housings whose dimensions, special materials or special seals are precisely matched to the application.

Schaeffler has many years of experience in the development of special housings. In order to achieve the best possible solution in customer-specific special cases, development is carried out in close partnership and consultation with the customer.

Portfolio

The most important features in the development of housings for specific industrial applications include:

- individual solutions for special requirements
- consideration of specific customer requirements, for example in sealing, the type of paint coatings or colours
- the use of state-of-the-art methods such as FEM in the calculation of the housing, *Figure 1*, page 383
- delivery options for complete units (bearings premounted in the housing).

For individually developed housings, Schaeffler also supplies the appropriate rolling bearings and other accessories. Furthermore, the industrial services experts at Schaeffler can also offer skilled mounting services.

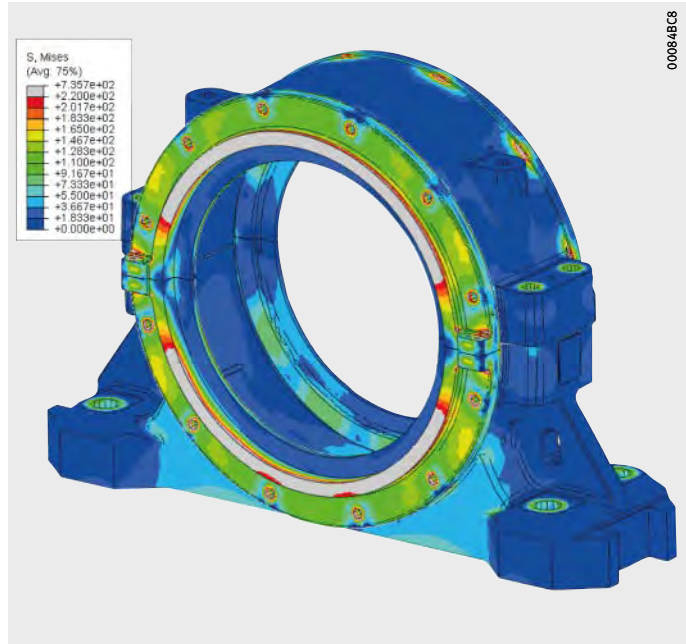

Figure 1
Calculation of a housing
by means of the FEM method



Housings for specific industrial applications

Application examples

The following examples of FAG special housings give an insight into the wide variety of industrial applications and design solutions.

Plummer block housings for the paper industry

In the paper industry, bearing housings PM30 are used for dryer cylinders, M.G. cylinders and Yankee cylinders, *Figure 2*. These cylinders are heated from within by means of steam that is fed into the cylinder via a hollow journal. The bearing housings are exposed to high ambient temperature and high humidity. Recirculating oil lubrication is therefore necessary in order to dissipate heat and allow the removal of any possible water ingress.

The bearings mainly used are spherical roller bearings, which allow compensation of any possible offset between the housings. The bearings are located either directly on a tapered journal or on the cylindrical shaft by means of a sleeve. Since substantial length increases occur due to heating of the cylinders, the housings are designed such that they allow considerable displacement of the non-locating bearing.



Figure 2
Plummer block housing PM30
for the paper industry

Water-cooled plummer block housings for continuous casting machines

Continuous casting is a continuous process in the steel industry in which molten steel is converted to the solid phase. This results in long products which are then processed further in finish rolling mills.

During cooling of the steel, it is guided as an endless strand on lines of driven rollers. The strand moves through two opposing rows of rollers and is cooled at the same time. There are various possibilities for cooling the strand. Direct cooling can be carried out by projecting water directly onto the strand and rollers, while indirect cooling can be carried out by cooling the rollers from within. Normally, the two cooling methods are applied in combination.

The rollers are supported by means of water-cooled plummer block housings SZA developed specifically for this application, *Figure 3*. The housings have a water-cooled upper housing section.

The housing is designed such that a specially split bearing is fitted with only one outer ring half. This is made possible by the load directions present in the lines of rollers in continuous casting machines. The seals are matched to the extreme operating conditions (high temperatures, spray water from strand cooling).

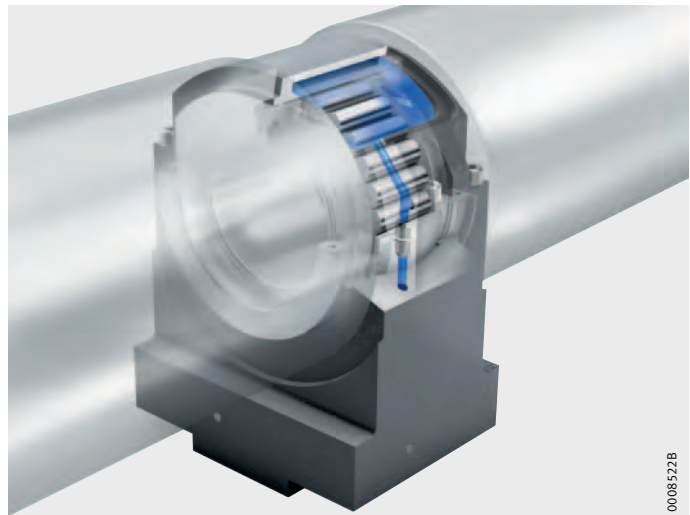

Figure 3
Water-cooled
plummer block housing for
continuous casting machines



Housings for specific industrial applications

Twin block housings for rotary kilns in cement production

The kiln shell of a rotary kiln is supported by riding rings. Each riding ring rests on two radial support rollers. In order to support the high radial and axial loads resulting from the motion process, robust rolling bearing arrangements are required for the support rollers.

The support roller is rigidly connected to the shaft by means of an interference fit and is abutted on both sides in the rolling bearings. Good lever ratios can be achieved by means of appropriate bearing spacings, so the tilting forces can be supported. Wide, low section height spherical roller bearings 241 with high basic load ratings are suitable for supporting radial and axial forces. They are generally lubricated with grease, which is also the case for the labyrinth seals in the housing. Depending on the load, FAG Arcanol LOAD400 or LOAD1000 is used. The housings are precisely matched to the requirements of the application in terms of lubrication, sealing and permissible misalignment.

Schaeffler supplies complete units RLR for radial support rollers, *Figure 4*, comprising:

- the housing
- two rolling bearings
- the shaft
- the support roller
- grease.

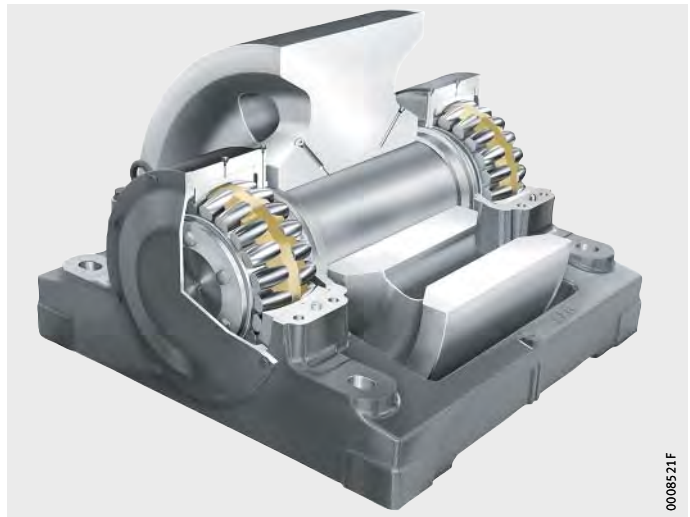

Figure 4
Twin block housing for rotary kilns
in cement production
(unit RLR)

Converter housings for steel production

Converters are used in the steel industry to produce steel from molten unrefined iron. When filled, large converter drums weigh several hundred tonnes. The trunnion bearing arrangement of converters represents a particular challenge due to the extreme loads and ambient conditions.

For trunnion bearing arrangements on converters, Schaeffler has developed split plummer block housings KPG and KPGZ, which are available as standard housings, see page 228. These housings, *Figure 5*, are large, heavy-section housings for spherical roller bearings 249 with shaft diameters from 510 mm to 1320 mm. Where necessary, housings for even larger shaft diameters can be designed and supplied.

On the basis of these housings, customer-specific solutions have been developed for special applications. The housings can be supplemented by the use of additional components and modified where necessary.

Complete packages with the following scope can be supplied:

- special spherical roller bearings
- housings with seals of various designs
- sensors for grease condition monitoring
- grease distributor plate with complete pipework to all lubrication points (bearing, seal and displacement sleeve in the non-locating bearing design)
- sensor systems for bearing condition monitoring.



Figure 5
Converter housing
for steel production



Housings for specific industrial applications

Flanged housing units for large electrical machinery

Special flanged housing units are available for rotor bearing arrangements in large electrical machinery. Depending on the application, one or more deep groove ball bearings, cylindrical roller bearings or angular contact ball bearings are integrated in the housing, *Figure 6*. The flanged housing units offer solutions that are particularly economical, versatile and appropriate to the application. Due to the flanged housing units, the design of the end shields is significantly simplified, resulting in considerable reductions in the construction work required on large motor housings. A wide range of sealing variants in all IP protection classes and various lubrication concepts allow versatile matching to the requirements of the specific applications.



Figure 6
Flanged housing unit FKB
with oil sump lubrication

Further information

- TPI 152, Flanged Housing Units for Large Electrical Machinery.



FAG



Housings for railway applications

Housings for railway applications

	Page
Products and services	Comprehensive product and service portfolio..... 392
	Wheelset bearing housings..... 392
	Further housings for railway applications 392
	Design and strength 393
	Materials and anti-corrosion protection..... 394
	Seals for wheelset bearings 394
Application examples	Universal wheelset bearings for diesel-hydraulic locomotives 397
	Standard housings for freight wagons 398
	Wheelset bearings for urban transport 400
	Wheelset bearings for regional trains 401
	Wheelset bearings for high speed trains..... 402
	Housing units with relubrication facility for traction motors 403



Housings for railway applications

Products and services

For the rail vehicle industry, Schaeffler offers a comprehensive range of products and services from a single source. In terms of bearing housings, this predominantly applies to wheelset bearing housings, but also to other housings for rail applications.

Comprehensive product and service portfolio

Schaeffler has many years of experience in the development of wheelset bearing housings. In order to achieve the best possible solution in customer-specific special cases, development is carried out in close partnership and consultation with the customer.

The most important criteria for FAG wheelset bearing housings are as follows:

- favourable price/performance ratio
- short lead times
- guarantee of long term supply
- proven design solutions
- worldwide delivery capability: from the region, for the region.

The range is rounded out by products for mounting, maintenance and diagnosis, mounting and diagnosis services, application engineering advisory work, training tools, PC calculation software and technical publications.

Wheelset bearing housings

The types of rolling bearings commonly used in wheelset bearing arrangements are tapered roller bearing units TAROL, cylindrical roller bearings, tapered roller bearings and spherical roller bearings. Units comprising bearings and housings are known as wheelset bearings.

Wheelset bearing housings are matched to the various mounting and operating conditions in:

- locomotives
- freight wagons
- urban transport (trams, metro lines)
- regional trains
- high speed trains.

In addition to wheelset bearing housings with standardised housing dimensions, Schaeffler offers an extensive range of parts for widely varying applications.

Further housings for railway applications

For the rail vehicle industry, Schaeffler also offers housings for specific applications:

- housings for traction motors
- motor suspension bearing housings.

Further information

- For further information and enquiries, please contact: rail_transport@schaeffler.com.

Design and strength

The housing must, as a connecting part between the vehicle bogie frame and the wheelset, reliably transmit the forces present. In terms of the design, it is important to know how the forces are introduced into the housing. A housing of a suitable geometry will give a favourable pressure distribution in the rolling bearing, thus reducing the specific load and preventing the occurrence of stress peaks in the contact surfaces transmitting load.

High safety requirements are placed on wheelset bearing housings. The design must be appropriate to the load arising from the operating conditions, even over long periods of several decades. In order to achieve this, a precise analysis of the loads occurring is necessary.

Calculation

Schaeffler uses state-of-the-art methods such as FEM calculation and topological optimisation, which give a description close to reality of not only difficult geometries but also the complex pattern of force flow in the housing. For the latter, a precise description of the interaction between the components is required, for example by means of a contact analysis. Valid design guidelines and a design brief prepared by the customer are required. A calculation-based strength analysis can be used as early as the design and development phase to identify weakpoints and optimise the geometry. In addition, this means that experimental investigations can be reduced to a minimum.

Experimental investigations

Upon customer request, a wide range of experimental investigations can be carried out such as vibration tests, salt spray tests and seal integrity tests. Furthermore, the performance tests for the wheelset bearings to EN 12082 are carried out in the original housings.



Housings for railway applications

Materials and anti-corrosion protection

The standard material for wheelset housings is spheroidal graphite cast iron EN-GJS-400-18-LT. Depending on customer requirements on characteristics such as mass, strength or weldability, other materials such as cast aluminium alloys or cast steel may be used.

All outer surfaces of housings machined by methods that are not chip-forming are provided with a coating system. Inner and outer surfaces machined by chip-forming methods are provided with anti-corrosion protection. If there are particular requirements relating to paint coating and anti-corrosion protection, special solutions are possible. If particular specifications are presented by the customer, we check their feasibility and these can be implemented if the result is positive.

Seals for wheelset bearings

In order that a wheelset bearing remains functionally capable, it is necessary to prevent the ingress of contaminant particles or liquids and the escape of lubricant. Sealing of the axle makes a very important contribution to maintaining the function of the wheelset bearing.

The term “protective seal” covers all types of seals that protect rolling bearings against the ingress of contaminant and loss of lubricant.

These seal types are differentiated into contact seals and non-contact seals. Based on the existing operating conditions, the seal type most suitable for the application is then determined.

For example, contact seals cannot be used in the high speed sector in very many cases due to the high circumferential velocities and the resulting generation of heat. In contrast, contact seals are necessary in the tram sector where circumferential velocities are lower and the tracks may become flooded.

In order to cover the whole spectrum of operating conditions, there is a wide range of seal variants, see table, page 395. The housings used for wheelset bearings are designed for grease lubrication.

In other applications in the rail sector, such as motor suspension bearing arrangements, oil lubrication can also be implemented if appropriate seals are used.

**Seal variants
for wheelset bearings**

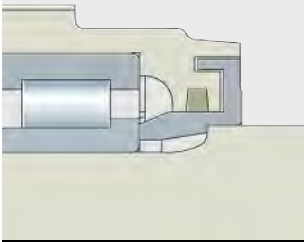
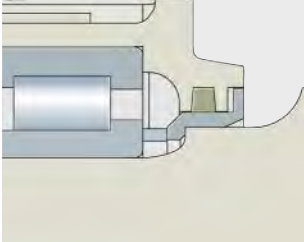
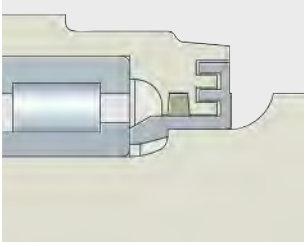
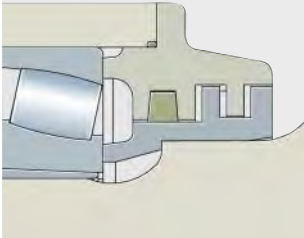
Seal	Characteristics
<p>Single axial labyrinth seal</p> 	<ul style="list-style-type: none"> ■ Small design envelope ■ Non-contact type ■ Improved sealing in combination with a felt seal, in this case no longer a non-contact type
<p>Single radial labyrinth seal</p> 	<ul style="list-style-type: none"> ■ Small design envelope ■ Also possible for use with split housings ■ Non-contact type ■ Improved sealing in combination with a felt seal, in this case no longer a non-contact type
<p>Double axial labyrinth seal</p> 	<ul style="list-style-type: none"> ■ Larger design envelope ■ Better labyrinth action ■ Non-contact type ■ Improved sealing in combination with a felt seal, in this case no longer a non-contact type
<p>Double radial labyrinth seal</p> 	<ul style="list-style-type: none"> ■ Larger design envelope ■ Better labyrinth action ■ Also possible for use with split housings ■ Non-contact type ■ Improved sealing in combination with a felt seal, in this case no longer a non-contact type



Housings for railway applications

Seal variants for wheelset bearings (continued)

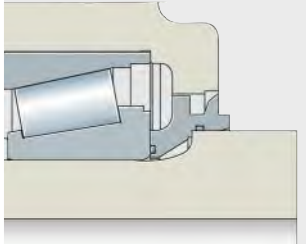
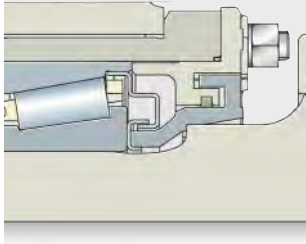
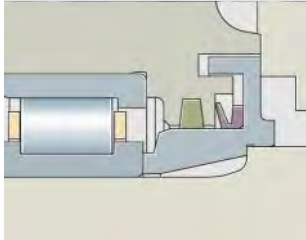
Seal	Characteristics
<p data-bbox="553 278 696 305">Splash ring seal</p> 	<ul style="list-style-type: none"> <li data-bbox="861 309 1009 337">■ Simple design <li data-bbox="861 339 1116 388">■ For use only in conjunction with sealed bearing <li data-bbox="861 390 1139 439">■ Suitable for use with split and unsplit housings <li data-bbox="861 441 1032 468">■ Non-contact type
<p data-bbox="553 611 897 638">Labyrinth seal with stuffing box packing</p> 	<ul style="list-style-type: none"> <li data-bbox="861 642 1201 691">■ Also suitable for high circumferential velocities <li data-bbox="861 693 1080 721">■ Small design envelope <li data-bbox="861 723 991 750">■ Contact type
<p data-bbox="553 944 1116 972">Combined seal comprising labyrinth seal, felt seal and V ring seal</p> 	<ul style="list-style-type: none"> <li data-bbox="861 980 1206 1029">■ Very good sealing action against ingress of foreign matter from outside <li data-bbox="861 1030 991 1058">■ Contact type

Application examples

The following examples show selected FAG housings for rail applications. They give an insight into various areas of application and the relevant design solutions.

Universal wheelset bearings for diesel-hydraulic locomotives

The application example shows wheelset bearings for diesel-hydraulic locomotives on mainline services and heavy shunting operation. The vehicles of various models are intended for use not only in various countries but also in cross-border travel. The modular construction allows the performance and configuration to be adapted to the conditions of the vehicle operators. The vehicles are designed for a maximum velocity of 120 km/h at a wheelset load of 25 t.

Wheelset bearings

Due to the modular structure and the intended usage of the locomotives in different countries, it was necessary to be able to use either tapered roller bearing units TAROL or cylindrical roller bearing units. Bearings of both types with the dimensions 150 mm×250 mm×160 mm (d×D×B) are interchangeable in the wheelset bearing, *Figure 1*.

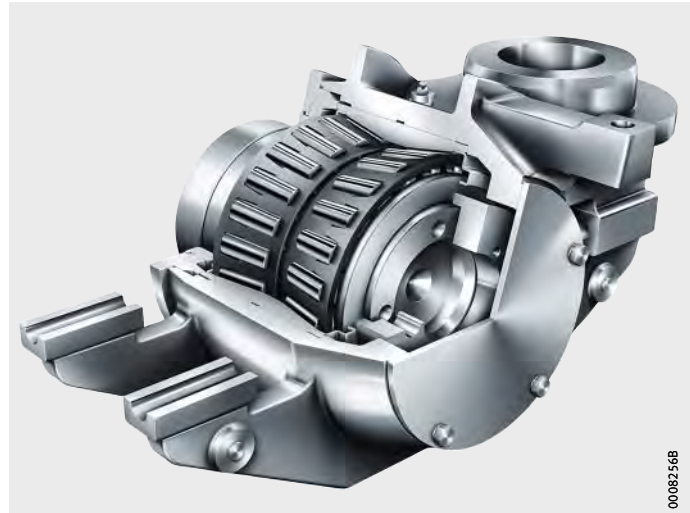

Figure 1
Universal wheelset bearing
for diesel-hydraulic locomotives

Wheelset bearing housings

The FAG wheelset bearing housing is of a single piece design and is made from spheroidal graphite cast iron EN-GJS-400-18-LT to EN 1563. The strength of the housing is optimised and confirmed by means of a structural analysis using FEM. The performance capacity of the wheelset bearing with TAROL units was tested and confirmed in accordance with EN 12082. Seal integrity testing was carried out in accordance with UIC 515-5.



Housings for railway applications

Standard housings for freight wagons

The Schaeffler product portfolio contains wheelset bearing housings for freight wagon bogies Y25-22,5t and Y25-25t to UIC. These housings are predominantly matched to shaft diameters of 120 mm and 130 mm, while housings for other diameters are available by agreement. The dimensions of the housings are standardised in order to ensure the greatest possible interchangeability.

Approval

The specified performance tests on wheelset bearings to EN 12082 and the dynamic fatigue tests on the housing body to UIC 510-3 were carried out successfully at independent certified test facilities. The FAG wheelset bearing housings thus passed all the necessary tests.

For the design Y25-25t, the German Federal Railway Authority for the first time issued a separate approval for the wheelset bearing housing as a component on the basis of these test results (EBA Identification no. OOG17A). At present, several thousand of these wheelset bearings are already in operation worldwide.

Wheelset bearings

In the wheelset bearing, the forces to be transmitted are supported by cylindrical roller bearings WJ and WJP.

In each wheelset, in other words on each axle, the following are installed:

- shaft diameter 120 mm:
2 cylindrical roller bearings WJ120×240-TVP and WJP120×240-P-TVP in each case
- shaft diameter 130 mm:
2 cylindrical roller bearings WJ130×240-TVP and WJP130×240-P-TVP in each case.

The calculated running distance is approx. 4 million km.

The bearings are separable and can be mounted and dismantled relatively easily, which allows rapid inspection of the functional surfaces of the bearings.

Wheelset bearing housings

The wheelset bearing housings are of a single piece design and are made from spheroidal graphite cast iron EN-GJS-400-18-LT to EN 1563 in accordance with the requirements of Deutsche Bahn.

The fatigue strength of the housings has been optimised and confirmed by means of a structural analysis using FEM. In practice, wheelset bearing housings thus remain in service for up to 30 years.

Seals For sealing of the cylindrical roller bearings in the housing, a multi-chamber labyrinth seal or a felt seal with an outer labyrinth have proved effective. Other seal variants are possible, see table, page 395.

Increased performance capability for Y25-25t

Due to the demand for increased levels of transport activity by rail, Schaeffler has worked in partnership with several European bogie manufacturers to develop a wheelset bearing optimised for an axle load of 25 t for use in freight wagon bogies Y25, *Figure 2*. In combination with the further development of the brakes, bogie frame and primary suspension as subassemblies, higher load per vehicle is now possible and the demand for maximisation of transport activity can be fulfilled. The particular advantage of the FAG product is that it is not only suitable for use with the spring sets commonly fitted but has already been designed for the higher housing loads that occur with innovative spring systems such as rubber roller springs or TKS springs.

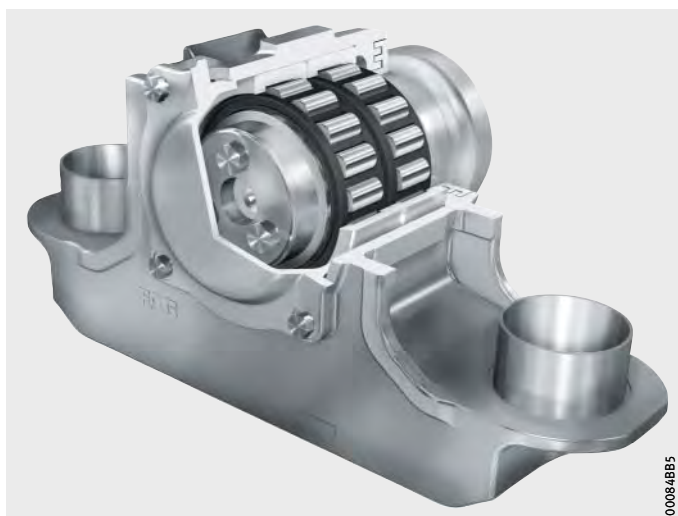

Figure 2
Wheelset bearing Y25-25t



Housings for railway applications

Wheelset bearings for urban transport

The application in this example is a tram in a low-floor design with bogies for operation in challenging climatic conditions. Development was focussed on key themes such as lightweight construction for maximum energy saving as well as reliability of the tram.

With a maximum axle load of 9 t, the tram can achieve a velocity of 80 km/h.

Wheelset bearings

The wheelset bearing, *Figure 3*, is designed for combination with special metal/rubber spring elements that are mounted directly on the housing.

The design of the wheelset with brake discs and coupling requires different solutions for axial location of the rolling bearings: this is achieved on one side of the wheelset by pressing on a tapered bush and on the other side by a threaded nut with an integrated labyrinth seal for the labyrinth seal.

The wheelset bearing is sealed on both sides by combined seals comprising a labyrinth seal and V ring seal in order to achieve high operational security. The rolling bearings used are cylindrical roller bearings.

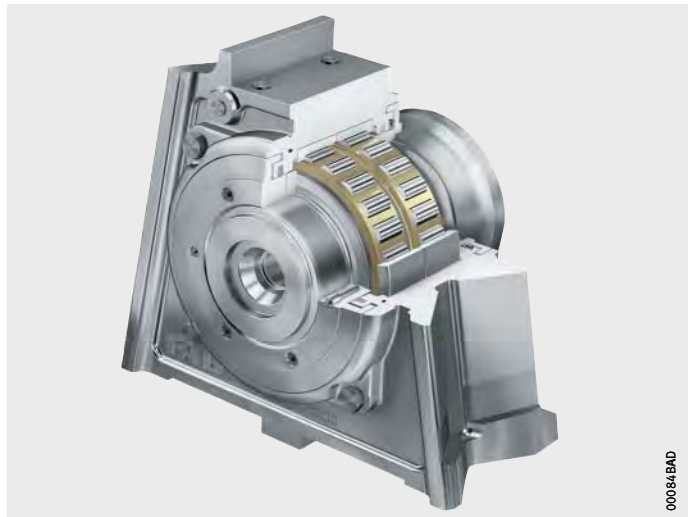

Figure 3

Wheelset bearing for tram

Wheelset bearing housings

The material used is EN AC- AlSi7Mg0,3ST6 to DIN EN 1706, a cast aluminium alloy proven for use in the wheelset bearing sector.

Wheelset bearings for regional trains

The application in this example is a regional train for commuters and urban transport links in towns. There is thus a requirement for high starting acceleration with stops occurring in rapid succession. In order to allow rapid entry and exit of passengers as well as access for those such as wheelchair users, the train is of a low-floor design. With a drive power of 12×250 kW, the train can reach a maximum velocity of 160 km/h.

Wheelset bearings

The wheelset bearing is designed as a swing arm housing, *Figure 4*. Schaeffler developed the swing arm as a split design, comprising an upper and lower section, housing ring and rolling bearings. Due to the split design, the wheelset can be replaced rapidly and easily.

Cylindrical roller bearings were selected as the rolling bearings. Due to the harsh weather conditions in the area of operation, particular attention was devoted to sealing on the wheel side.

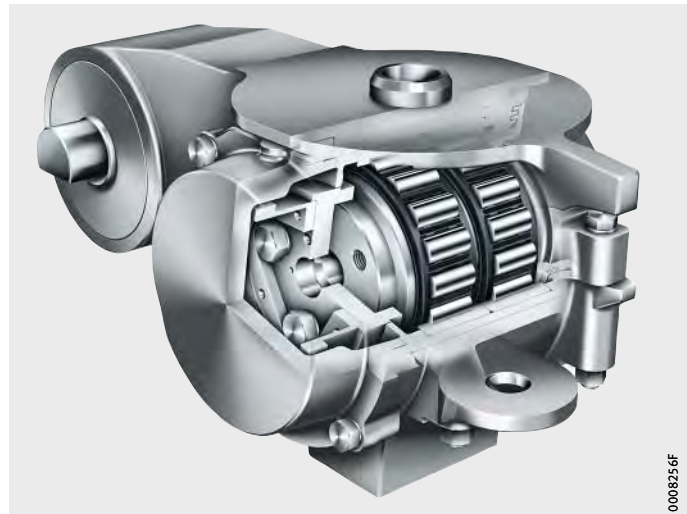

Figure 4
Wheelset bearing
for regional trains

Wheelset bearing housings

The material used for the wheelset swing arm is spheroidal graphite cast iron to DIN EN 1563 with a defined notched impact energy in the lower temperature range. The strength of the housing structure was investigated, optimised and confirmed by means of FEM calculation.



Housings for railway applications

Wheelset bearings for high speed trains

The application in this example is a high speed train for Russia. The trains are 250 m long and are equipped with several drive axles distributed over the length of the train. As a result, there is no need for traction units and additional passenger space can be gained. The trains are designed for a maximum travel velocity of 300 km/h.

Wheelset bearings

The wheelset bearing is designed as a swing arm, *Figure 5*. The swing arm was completely developed at Schaeffler and comprises an upper and lower section, housing ring and rolling bearing. Operation on the Russian broad gauge system leads to high axle loads. Tapered roller bearing units TAROL with the dimensions 150 mm×250 mm (d×D) are used.



Figure 5
Wheelset bearing
for high speed trains

Wheelset bearing housings

The material used for the swing arm housing is spheroidal graphite cast iron to DIN EN 1563 with a defined notched impact energy in the lower temperature range. This means that the extreme requirements (notched impact energy of 12 J at $-50\text{ }^{\circ}\text{C}$) can be fulfilled.

The strength of the housing structure was investigated, optimised and confirmed by means of FEM calculation, taking account of the particular requirements in relation to operating temperatures.

The suitability of the wheelset bearing was confirmed for the operating conditions present by means of a performance test in accordance with EN 12082 and safety standards within the Russian certification system.

Housing units with relubrication facility for traction motors

The requirements placed on modern drive concepts and for their high and rapid availability are increasing. For the rotor bearing arrangements in electric drives, Schaeffler works in consultation with customers to develop and manufacture complete housing units with a relubrication facility that are individually designed in accordance with the application and can also be equipped with measurement technology. Both standard bearings and current-insulating bearings can be used. In these units, all the housing components can be coated with Corrotect.

Modular concept

FAG housing units offer numerous advantages in the design, production, mounting and maintenance of rotor bearing arrangements. Since the housing units are designed as a modular concept, all the subassemblies are matched to each other, *Figure 6*. They form a closed unit that is normally mounted externally on the end shield. Due to the significantly simplified design of the end shields, the work involved in the development of new drive concepts is also reduced.

- ① Cover
- ② Labyrinth ring
- ③ Bearing
- ④ Housing
- ⑤ Labyrinth ring

Figure 6
Individual parts of a housing unit for traction motors



Design

The rotor bearing arrangement must be matched to the particular operating and ambient conditions of the electric drive concept. Depending on the drive concept, widely differing bearing loads must be taken into consideration in order to achieve electric drives that are efficient, operationally reliable and cost-effective.



Housings for railway applications

Housing units

The housing bodies of the housing units, *Figure 7*, are made in preference from spheroidal graphite cast iron. The lubrication and sealing must be configured such that the bearings are supplied with the correct quantity of lubricant in any operating mode. Due to their design, these bearing solutions are extremely easy to maintain.



Figure 7
Housing unit for traction motors

Further information

- RFB 21, FAG Housing Unit with Relubrication Facility for Traction Motors.



FAG



Mounting and maintenance



Mounting and maintenance

	Page
Products and services	
Features	407
Industrial Aftermarket	408
Mounting Toolbox – mounting made easy	408
Mounting	
Product overview	410
Features	412
Mounting and dismantling services	412
Equipment rental.....	413
Mechanical tools.....	414
Thermal tools.....	414
Hydraulic tools.....	416
Lubrication	
Product overview	418
Features	419
Services.....	419
Lubricants.....	419
Lubrication devices	422
Condition Monitoring	
Product overview	424
Features	425
Continuous monitoring.....	425
Regular monitoring.....	426
Condition monitoring with FAG SmartCheck	427
Lubricant monitoring with FAG GreaseCheck	428
Comprehensive monitoring.....	429

Products and services

Features Within its Industrial Aftermarket function, Schaeffler offers high quality products, services and training, *Figure 1*.

Portfolio The portfolio comprises:

- Mounting
- Lubrication
- Condition Monitoring
- Reconditioning.

The employees of Schaeffler worldwide will be pleased to help you select the ideal products, services and training courses, *Figure 1*.



Figure 1
Portfolio



Products and services

Industrial Aftermarket

Schaeffler Industrial Aftermarket (IAM) is responsible for replacement parts and service business for end customers and sales partners in all significant industrial sectors. On the basis of innovative solutions, products and services relating to rolling bearings, the service function of Schaeffler Industrial Aftermarket offers a comprehensive portfolio that covers all phases in the lifecycle of the bearing and takes account of the total costs (TCO).

The aim is to help customers save on maintenance costs, optimise plant availability and avoid unforeseen machine downtime. Schaeffler Industrial Aftermarket offers each customer an individual concept solution.

Schaeffler has centres of competence all around the world. This means we can provide customers worldwide with products, services and training quickly and professionally. All service employees worldwide undergo a comprehensive training programme and are audited regularly by officially certified specialists. This ensures that services throughout the world conform to a uniformly high standard of quality.

Mounting Toolbox – mounting made easy

The Schaeffler Mounting Toolbox, *Figure 2*, brings together valuable knowledge relating to mounting and dismounting. In individual video sequences, the service experts present step by step the points that must be paid close attention for correct mounting, lubrication and alignment.

<http://mounting-toolbox.schaeffler.de>

Figure 2
Mounting Toolbox





Product overview Mounting

Mounting and dismounting services

MOUNT-HOUR



Mechanical tools

Double hook wrench set
Internal extractor

LOCKNUT-DOUBLEHOOK...SET



PULLER-INTERNAL10-100-SET



Thermal tools

Induction heating devices
Medium frequency devices

HEATER600



HEAT-GENERATOR,
HEAT-INDUCTOR

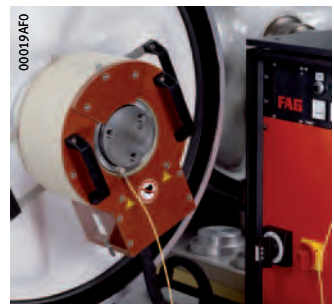

Hydraulic tools
Hydraulic nuts

HYDNUT

00019B00



Hand pumps for drive-up distance

PUMP1000-4L-CONTROL

000179C2



Mounting

Features

The Schaeffler industrial service experts offer mounting services for bearing arrangement units, comprising bearings and housings, that are applicable across industrial sectors. They have detailed knowledge and extensive experience in all industrial sectors.

At several locations worldwide, Schaeffler has skilled personnel specifically trained for the Industrial Aftermarket sector who can provide reliable, rapid and competent assistance. The services are provided either at the customer's location or in the Schaeffler workshop facilities.

Mounting and dismounting services

These services, *Figure 1*, include:

- mounting and dismounting of bearings and bearing arrangement systems
- problem solving and preparation of concept solutions
- measurement and condition analyses
- maintenance and inspection of bearing arrangements
- support in achieving optimum mounting operations
- certification of mounting processes
- design and manufacture of special tools.



Figure 1
Mounting service on a converter

- Advantages** The services give the following advantages:
- worldwide portfolio of services for bearing arrangement technology
 - mounting experts with comprehensive experience in highly diverse applications
 - increased equipment availability and improvements in productivity
 - optimisation of mounting and dismantling processes
 - training and awareness measures for employees relating to the correct handling of bearings of all types.

Further information ■ Enquiries: mounting-services@schaeffler.com, +49 9721 91 4995.

Equipment rental A wide range of special tools for correct mechanical mounting and dismantling and for measurement and inspection tasks can be rented from Schaeffler on a weekly basis for a fee.

Schaeffler offers rental of:

- mechanical tools (such as extractors)
- thermal tools (such as HEATER or medium frequency equipment)
- hydraulic tools (such as hydraulic pumps or hand pumps)
- measurement and inspection equipment (such as taper gauges or enveloping circle gauges).

If one of our qualified service personnel is commissioned in order to carry out the particular activity, the equipment rental is generally free of charge.

Further information ■ Enquiries: mounting-services@schaeffler.com, +49 9721 91 4995.



Mounting

Mechanical tools

Mechanical tools are generally used for the mounting and dismounting of small and medium-sized bearings. The mounting forces are transmitted by the form fit effect. The Schaeffler range includes items such as hook and pin wrenches, socket wrenches and a wide variety of extractors.

Further information

■ Catalogue IS 1, Mounting and Maintenance of Rolling Bearings.

Thermal tools

Induction heating devices are used to heat rolling bearings or components with a cylindrical bore for mounting and dismounting. In addition to various induction heating devices operating with mains frequency technology, Schaeffler also offers induction heating devices with medium frequency technology.

Adequate expansion of the housings and bearings is normally achieved at +80 °C to +100 °C. During the heating operation, the maximum heating temperature must be observed. The temperature of rolling bearings must not normally exceed +120 °C, in order to prevent changes to the structure and hardness of the bearing. In all devices for heating, the temperature can be steplessly controlled.



Wear protective gloves during mounting and dismounting of heated parts.

Induction units with medium frequency technology

FAG heating devices with medium frequency technology give rapid, simple heating of medium-sized to large bearings, housings and similar steel parts for mounting and dismounting. The device always comprises two parts: an inductor and a generator, *Figure 2*, page 415.

The inductor can be of a flexible or rigid design. The rigid design is particularly suitable for batch applications. The flexible design of inductor can be wound around the components.

Each device is designed for the specific application and is fitted, depending on the workpiece, with flexible or rigid inductors. Due to its compact construction, the device can also be used for mobile operation.



Figure 2
Heating device
with medium frequency technology:
generator and inductor

Advantages

The advantages of the heating device with medium frequency technology are as follows:

- two in one: suitable for mounting and dismounting
- operating frequency from 10 kHz to 25 kHz
- efficiency of the generator higher than 90%
- low energy requirements
- short heating times
- control of heating according to time and temperature
- automatic demagnetisation
- flexible and rigid inductors available
- suitable for use either inside or outside component
- lower mains connection power than heating devices with mains frequency
- almost silent
- air-cooled system.



Mounting

Hydraulic tools

Hydraulic tools can be used to apply large forces. These tools are therefore particularly suitable for the mounting and dismounting of large bearings or components with a tapered bore.

Hydraulic nuts are used as a mounting tool. Pressure can be generated using oil injectors, hand pumps or hydraulic units.

Hydraulic nuts

Hydraulic nuts HYDNUT, see table, are used to press components with a tapered bore onto their tapered seat. Presses are mainly used if the drive-up forces required cannot be applied using other accessories, e.g. shaft nuts or pressure screws.

The main applications are as follows:

- mounting and dismounting of bearings with tapered bore.
These bearings with a tapered bore can be seated directly on a tapered shaft, an adapter sleeve or a withdrawal sleeve.
- dismounting of withdrawal sleeves and adapter sleeves.

Available hydraulic nuts

Designation	Design	Application
HYDNUT50 to HYDNUT200	With metric fine pitch thread to DIN 13	Adapter and withdrawal sleeves with metric dimensions
HYDNUT205 to HYDNUT1180	With trapezoidal thread to DIN 103	
HYDNUT90-INCH to HYDNUT530-INCH	With inch size thread to ABMA "Standards for Mounting Accessories, Section 8, Locknut Series N-00"	Sleeves with inch dimensions
HYDNUT100-HEAVY to HYDNUT900-HEAVY	Increased capacity design with smooth bore	For high mounting forces, for example in shipbuilding

Further information

- TPI 196, FAG Hydraulic Nuts
- Enquiries: industrial-services@schaeffler.com, +49 2407 9149-66.

Pump for drive-up distance

The hand pump PUMP1000-4L-CONTROL is particularly suitable as a pressure generation device where bearings with a tapered bore are to be driven onto their seat using a hydraulic nut, *Figure 3*.

First, the bearing is driven smoothly onto the tapered seat as far as the initial position. A suitable hydraulic nut is then screwed onto the shaft and the hand pump is connected. The hand pump is then operated until the pressure to reach the start position is achieved. By further operation of the pump, the bearing is driven up by the required distance and thus reaches the final position.

The user manual for the pump PUMP1000-4L-CONTROL contains a table that shows the number of strokes necessary to achieve the required drive-up distance of the bearing. The required drive-up distance is calculated using the software Mounting Manager.

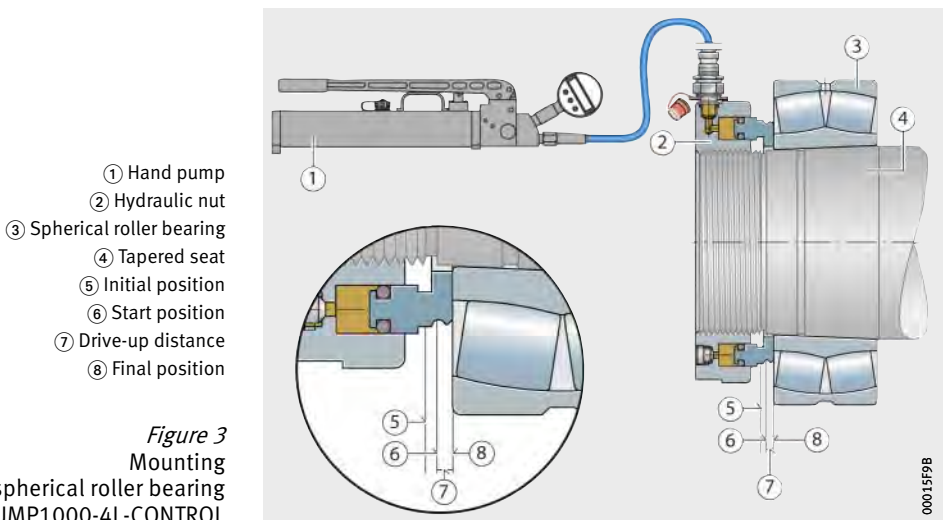

Figure 3
Mounting
of a spherical roller bearing
using PUMP1000-4L-CONTROL

Scope of delivery

Hand pump with digital manometer
High pressure hose with coupling sleeve
Spacer ring (HYDNUT50 to HYDNUT150)
Push fit coupling nipple
User manual
Metal case

Ordering designation

PUMP1000-4L-CONTROL



Product overview Lubrication

Arcanol greases

ARCANOL



00019AE

Lubrication system

CONCEPT8



0007FD1A

Lubrication

Features In more than half of all cases, inadequate lubrication is the cause of unplanned machine downtime. The life of machine elements undergoing swivel, rotary or linear motion can be significantly extended by the use of greases appropriate to the different operating and environmental conditions as well as the definition of and adherence to lubrication intervals and quantities.

Services Services relating to lubrication include:

- selection of lubricants and lubrication systems
- preparation of lubrication and maintenance plans
- lubrication point management
- consultancy on lubricants
- lubricant investigations and tests.

Advantages The services provide assistance in:

- preventing failures
- increasing productivity
- reducing lubrication costs.

Lubricants The lubricants available from Schaeffler are designed and tested for bearing arrangement technology, *Figure 1*.

Rolling bearing greases Arcanol The 18 greases cover almost all applications. They are developed by experienced application engineers and are produced by the best manufacturers in the market. Different greases are used depending on the particular application, see table, page 420.

Rolling bearing greases under the name Arcanol are subjected to 100% quality inspection. The inspection methods at Schaeffler are among the most demanding in the market. As a result, Arcanol rolling bearing greases fulfil the highest quality requirements.



Figure 1
Analysis of the thermal behaviour
of greases



Lubrication

Rolling bearing greases Arcanol

Arcanol grease	Designation to DIN 51825	Classification
MULTI2	KP2K-30	Low-noise ball bearing grease for $D \leq 62$ mm
MULTI3	K3K-20	Standard ball bearing/insert bearing grease for $D > 62$ mm
SPEED2,6	KPHC2/3K-40	Standard spindle bearing grease
MULTITOP	KPHC2N-40	Universal high performance grease
TEMP90	KP3P-40	Low-noise rolling bearing grease, up to +160 °C
TEMP110	KP2P-30	Universal grease for higher temperatures
TEMP120	KPHC2R-30	Grease for high temperatures and high loads
TEMP200	KFKP2U-30	Rolling bearing grease for $T > +150$ °C to +260 °C
LOAD150	KP2N-20	Multi-purpose grease for automotive applications, high performance grease for line contact
LOAD220	KP2N-20	Heavy duty grease, wide speed range
LOAD400	KP2K-20	Grease for high loads, shocks
LOAD460	KP1K-30	Grease for high loads, vibrations, low temperatures
LOAD1000	KP2K-20	Grease for high loads, shocks, large bearings
FOOD2	KPHC2K-30	Grease with foodstuffs approval
VIB3	KP3N-30	Grease for oscillating motion
BIO2	KPE2N-40	Grease with rapid biodegradability
CLEAN-M	KX2R-30	Clean room grease, grease resistant to radiation
MOTION2	KPFHC2K-40	High performance grease paste for oscillating applications and plain bearing arrangements

Type of grease Thickener Base oil	Operating temperature range °C	Upper continuous limit temperature $T_{upperlimit}$ °C	NLGI grade	Speed parameter $n \cdot d_M$ $min^{-1} \cdot mm$	Kinematic viscosity	
					at 40 °C mm ² /s	at 100 °C mm ² /s
Lithium soap Mineral oil	-30 to +120	+75	2	500 000	110	11
Lithium soap Mineral oil	-20 to +120	+75	3	500 000	110	12
Lithium soap Synthetic oil	-40 to +120	+80	2 to 3	2 000 000	25	6
Lithium soap Partially synthetic oil	-40 to +140	+80	2	800 000	82	12,5
Polycarbamide Partially synthetic oil	-40 to +160	+90	3	700 000	148	15,5
Lithium complex soap Partially synthetic oil	-30 to +160	+110	2	500 000	130	14,2
Polycarbamide Synthetic oil	-30 to +180	+120	2	300 000	400	40
PTFE Perfluoropolyether oil	-30 to +260	+200	2	300 000	550	49
Lithium complex soap Mineral oil	-20 to +140	+95	2	500 000	160	15,5
Lithium/calcium soap Mineral oil	-20 to +140	+80	2	500 000	245	20
Lithium/calcium soap Mineral oil	-20 to +120	+80	2	400 000	400	27
Lithium/calcium soap Mineral oil	-30 to +130	+80	1	400 000	400	25
Lithium/calcium soap Mineral oil	-20 to +130	+80	2	300 000	1 000	38
Aluminium complex soap White oil	-30 to +120	+70	2	400 000	150	18
Lithium complex soap Mineral oil	-30 to +150	+90	3	350 000	170	14
Lithium/calcium soap Synthetic oil	-40 to +150	+80	2	300 000	55	10
Polycarbamide Ether	-30 to +180	+90	2	850 000	103	12,8
Lithium soap Synthetic oil	-40 to +130	+75	2	500 000	50	8



Lubrication

Lubrication devices

Lubricators and lubrication systems automatically provide rolling bearings with the correct quantity of lubricant. This prevents the most frequent cause of rolling bearing failure: inadequate or incorrect lubrication. Approximately 90% of bearings are lubricated with grease. Relubrication with the correct quantity of grease at the appropriate intervals gives a significant increase in the life of bearings.

Lubrication systems

A single-point or multi-point lubrication system can supply lubrication points precisely and irrespective of temperature. The dispensing times can be set variably.

Lubrication system CONCEPT8

This single-point and multi-point lubrication system can grease up to eight lubrication points, *Figure 2*. LC units are available in the size 800 cm³. The lubrication system controls the greasing of the lubrication points independently of the machine.



Figure 2
Lubrication system CONCEPT8
with 8 outlets

Advantages

The advantages of the lubrication system are as follows:

- suitable for oil and grease up to NLGI 3
- reliable piston pump as delivery pump
- operating temperature from $-20\text{ }^{\circ}\text{C}$ to $+70\text{ }^{\circ}\text{C}$
- low operating voltage of 24 DCV
- pressure buildup to max. 70 bar, thereby overcoming any obstructions.

Bearing housings such as split plummer block housings SNS can be connected directly to CONCEPT8, *Figure 3*.



Figure 3
Plummer block housing SNS
with FAG CONCEPT8

Further information

- WL 80382, FAG CONCEPT8
- Catalogue IS 1, Mounting and Maintenance of Rolling Bearings
- Enquiries: industrial-services@schaeffler.com,
+49 2407 9149-66.



Product overview Condition Monitoring

Online monitoring system SmartCheck

SMART-CHECK



Grease sensor GreaseCheck

GREASE-CHECK

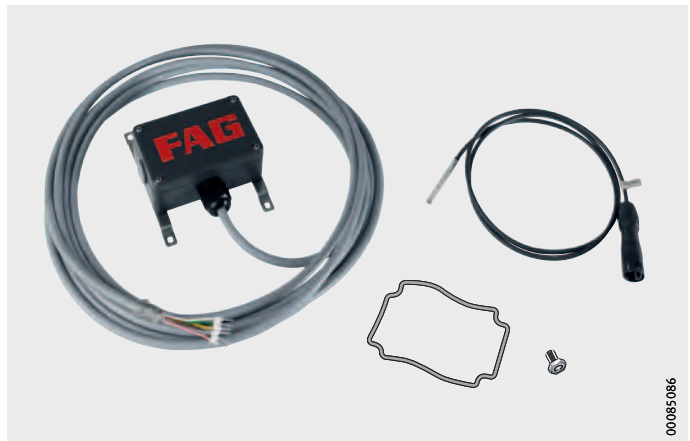

Condition Monitoring

Features The malfunction-free and optimised operation of complex machinery and plant can normally only be achieved by means of condition-based maintenance. By preference, Schaeffler uses vibration diagnosis for this task.

This method makes it possible to detect damage in machinery at a very early stage. This means that, for example, damaged components can be replaced as part of planned downtime. Unscheduled downtime is avoided.

Depending on the type of machine and its importance for the production process, condition monitoring can be carried out by means of either continuous (online) monitoring or regular (offline) monitoring.

Continuous monitoring For production-critical machinery, continuous monitoring, *Figure 1*, by means of vibration diagnosis is indispensable in many cases.

In addition to giving advice on selecting the right system, Schaeffler also implements monitoring of the machine. This includes not only hardware selection but also system configuration and, where necessary, its integration into existing systems.

The customer can decide whether to carry out plant monitoring himself or to enlist the services of Schaeffler for online monitoring. Due to the communication options of the monitoring systems, remote analysis can be carried out by the Schaeffler experts.



Figure 1
Continuous monitoring



Condition Monitoring

Regular monitoring

The failure of so-called “B” or “C” category plant items does not lead directly to downtime and does not therefore necessarily entail expensive secondary damage. In the case of such machine parts, regular monitoring is generally recommended as a more economical option.

In this type of monitoring, machinery is examined and assessed by vibration analysis at regular intervals, for example every four weeks. This regularity gives more in-depth knowledge of the normal condition of the machine. Deviations can thus be detected.

For the monitoring concept, the selection of measurement points and monitoring accessories as well as the measurement interval play a decisive role. If deviations occur during measurement or if trends are to be investigated, the data can be sent to the Schaeffler Diagnosis Centre. Vibration experts will then analyse the data and prepare a diagnosis report. Through working with the Schaeffler experts, customers can build up their own know-how in analysis.

If no personnel are available for data logging, Schaeffler can also offer support in data logging. The Schaeffler experts can then carry out regular measurements on site.

Troubleshooting

Where malfunctions occur on a machine, defects must be detected and rectified very quickly. Based on many years of experience with different sectors and applications, the Schaeffler diagnosis experts are well versed in such troubleshooting tasks.

Problems or malfunctions in machine operation often become apparent through changes in vibration behaviour, unusual temperature patterns or similar phenomena. The investigation is closed out by a handover discussion between the diagnosis experts and all relevant employees on site. In addition to the results of the investigation, the recommended countermeasures are discussed in particular.

Further information

■ Enquiries: industrial-services@schaeffler.com,
+49 2407 9149-66.

Condition monitoring with FAG SmartCheck

For condition-based maintenance, Schaeffler uses vibration diagnosis as a preferred method. FAG SmartCheck is an innovative, economical measuring system for real time monitoring and can be mounted, for example, at predefined positions on plummer block housings SNS, *Figure 2*. The figure shows possible mounting positions, although only 1 FAG SmartCheck is required per housing.



- ① Preferred position for FAG SmartCheck
- ② Alternative position for FAG SmartCheck

Figure 2
Plummer block housing SNS
with FAG SmartCheck

Commissioning, *Figure 3*, is simplified since the device is supplied already loaded with a characteristic value set and predefined configuration templates. These can easily be matched to individual requirements.



Figure 3
Commissioning of FAG SmartCheck



Condition Monitoring

Advantages

The compact measuring device can be installed quickly, is easy to use and contributes to the reduction of life cycle costs.

Further advantages include:

- reliable real time monitoring of the machine
- intelligent process monitoring
- intuitive user concept
- ease of integration in the controller and control facility
- modular accessories SmartLamp, SmartConnectBox and SmartController
- complete service from a single source.

Lubricant monitoring with FAG GreaseCheck

Bearing arrangement units comprising a bearing and housing are lubricated with oil or grease. The monitoring of grease condition in ongoing operation can be achieved, for example, using FAG GreaseCheck, *Figure 4*. Due to its special electronic evaluation system, relubrication is no longer carried out as a function of time but as a function of condition. In this way, relubrication can be carried out at the correct time, making it possible to delay and in many cases completely prevent rolling bearing damage.

- ① Optical probe
- ② Electronic evaluation system

Figure 4
Grease sensor FAG GreaseCheck



Advantages

FAG GreaseCheck makes it possible to achieve:

- lubrication appropriate to needs
- increased plant availability
- optimised grease quantities and relubrication intervals
- lower lubricant costs
- lower service and maintenance costs.

Comprehensive monitoring

An innovative system for comprehensive monitoring combines grease and vibration diagnosis with a lubricator that is controlled by the monitoring devices. In this way, any critical change during ongoing operation can be detected and rectified at an early stage before damage occurs in the rolling bearing. In particular, plant that is difficult to access or failure-critical can be comprehensively monitored and always provided with an optimum supply of grease, without the need for skilled personnel to be present on site, *Figure 5*.

- ① FAG GreaseCheck
- ② Arcanol greases
- ③ FAG CONCEPT8
- ④ FAG SmartCheck

Figure 5
Comprehensive monitoring
of rolling bearings

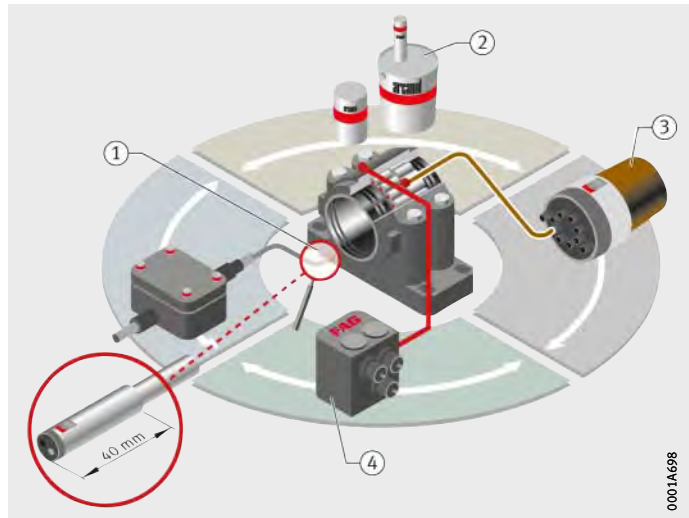

Addresses

Germany Schaeffler Technologies AG & Co. KG
Postfach 1260
97419 Schweinfurt
Georg-Schäfer-Straße 30
97421 Schweinfurt
Tel. +49 2407 9149-66
Fax +49 2407 9149-59
info@schaeffler-iam.com
www.schaeffler-iam.com

Worldwide You can find all
the addresses and contacts
for Schaeffler at
www.schaeffler.com

Notes



Notes

**Schaeffler Technologies
AG & Co. KG**

Georg-Schäfer-Straße 30
97421 Schweinfurt
Germany

Internet www.fag.com

E-mail faginfo@schaeffler.com

In Germany:

Phone 0180 5003872

Fax 0180 5003873

From other countries:

Phone +49 9721 91-0

Fax +49 9721 91-3435

